



Designation: D 5748 – 95 (Reapproved 2001)

## Standard Test Method for Protrusion Puncture Resistance of Stretch Wrap Film<sup>1</sup>

This standard is issued under the fixed designation D 5748; the number immediately following the designation indicates the year of original adoption or, in the case of revision, the year of last revision. A number in parentheses indicates the year of last approval. A superscript epsilon ( $\epsilon$ ) indicates an editorial change since the last revision or reapproval.

### 1. Scope

1.1 This test method determines the resistance of a stretch wrap film to the penetration of a probe at a standard low rate, a single test velocity. Performed at standard conditions, the test method imparts a biaxial stress that is representative of the type of stress encountered in many product end-use applications. The maximum force, force at break, penetration distance, and energy to break are determined.

1.2 *This standard does not purport to address all of the safety concerns, if any, associated with its use. It is the responsibility of the user of this standard to establish appropriate safety and health practices and determine the applicability of regulatory limitations prior to use.*

### 2. Referenced Documents

2.1 *ASTM Standards:*<sup>2</sup>

D 618 Practice for Conditioning Plastics for Testing

D 996 Terminology of Packaging and Distribution Environments

D 1898 Practice for Sampling of Plastics<sup>3</sup>

D 2103 Specification for Polyethylene Film and Sheeting

E 122 Practice for Calculating Sample Size to Estimate, With a Specified Tolerable Error, the Average for a Characteristic of a Lot or Process

E 691 Practice for Conducting an Interlaboratory Study to Determine the Precision of a Test Method

### 3. Terminology

3.1 *Definitions*—General definitions for packaging and distributions environments are found in Terminology D 996.

3.2 *Definitions of Terms Specific to This Standard:*

3.2.1 *break force*—force achieved at break.

3.2.2 *energy*—work to break.

3.2.3 *maximum force*—greatest force achieved.

3.2.4 *penetration distance*—depth probe traveled in penetrating film specimen, from initial probe contact with film specimen, to penetration at break.

3.2.5 *protrusion puncture resistance*—the ability of a plastic film to withstand the force exerted by a protrusion.

3.2.6 *thickness (caliper, gage)*—the perpendicular distance between the opposite surfaces of a plastic film.

### 4. Significance and Use

4.1 Puncture resistance is very important in end-use performance of stretch wrap film used in consumer and industrial product applications. Puncture resistance is a measure of the energy-absorbing ability of a stretch wrap film in resisting a protrusion. The test method is designed to provide the user with a means of measuring the stretch wrap film's puncture resistance performance under essentially biaxial deformation conditions. A biaxial stress is representative of the type of stress encountered by stretch wrap products in many end-use applications.

4.2 Although this test method cannot be expected to duplicate all field experiences, since the rate of speed, weight, and configuration of such destructive forces vary widely, a generally reliable comparison of samples may be made from the data obtained.

### 5. Apparatus

5.1 *Universal Testing Apparatus.*

5.2 *Integrator and Chart Recorder.*

5.3 *Appropriate Load Cell*—The test may be performed using compression or tension load cell.

5.4 *Probe*—A 0.75 in. (19 mm) diameter pear-shaped TFE-fluorocarbon coated probe<sup>4</sup> (Fig. 1), for general application and standard comparison of plastic films and interlaboratory results.

5.5 *Specimen Clamping Fixture* (Fig. 2).

5.6 *Micrometre*, conforming to Specification D 2103.

5.7 *Template*, 6 by 6 in. (150 by 150 mm).

<sup>1</sup> This guide is under the jurisdiction of ASTM Committee D10 on Packaging and is the direct responsibility of Subcommittee D10.25 on Palletizing and Unitizing of Loads.

Current edition approved July 15, 1995. Published September 1995.

<sup>2</sup> For referenced ASTM standards, visit the ASTM website, www.astm.org, or contact ASTM Customer Service at service@astm.org. For *Annual Book of ASTM Standards* volume information, refer to the standard's Document Summary page on the ASTM website.

<sup>3</sup> Withdrawn.

<sup>4</sup> The probe is coated with duPont 954-101 Teflon S a thickness of 0.0015 in. (0.0381 mm). Available from duPont.

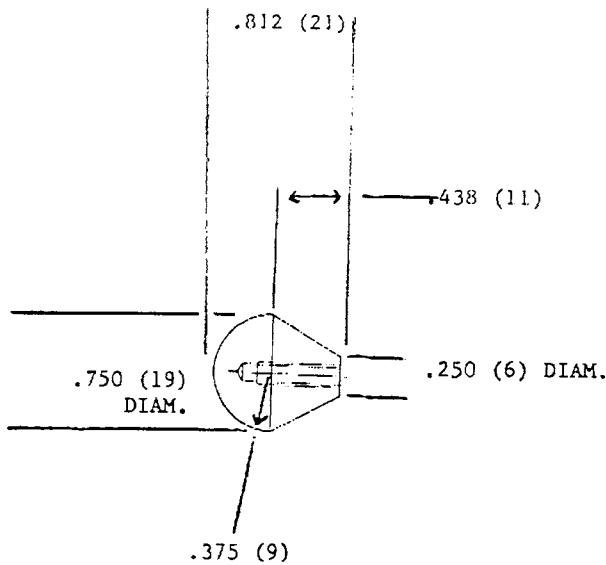

NOTE 1—Measurements are in inches (millimetres).  
**FIG. 1 Probe**

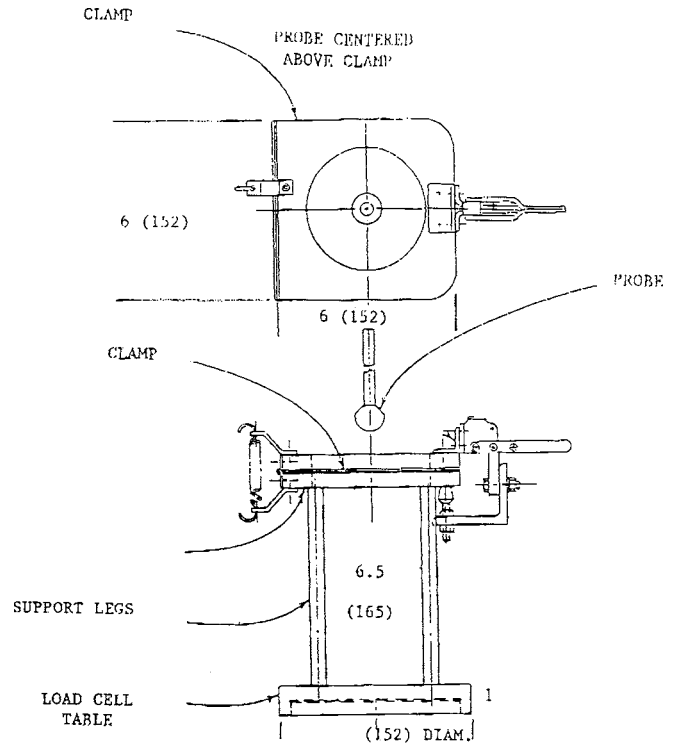

NOTE 1—Measurements are in inches (millimetres).  
**FIG. 2 Clamp**

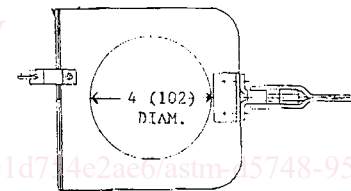

5.8 Specimen Cutter.

**6. Sampling**

6.1 *Acceptance Sampling*—Sampling shall be in accordance with Practice **D 1898**.

6.2 *Sampling for Other Purposes*—The sampling and the number of test specimens depend on the purpose of the testing. Practice **E 122** is recommended. Test specimens are taken from several rolls of film, and where possible, from several production runs of film. Strong conclusions about a specific property of a film cannot be based on a single roll of film.

**7. Number of Test Specimens**

7.1 Test a minimum of five specimens for each sample.

**8. Preparation of Apparatus**

8.1 For specific instruction in setting up and operating the apparatus, consult the operations manual.

8.2 Install probe apparatus (**Fig. 2**).

8.3 Center the probe (**Fig. 1**) over the specimen clamping fixture (**Fig. 2**).

**9. Conditioning**

9.1 Condition the test specimens at  $73.4 \pm 3.6^\circ\text{F}$  ( $23 \pm 2^\circ\text{C}$ ) and  $50 \pm 5\%$  relative humidity for not less than 40 h prior to testing in accordance with Procedure A of Practice **D 618**.

9.2 Conduct tests in the standard laboratory atmosphere of  $23 \pm 2^\circ\text{C}$  ( $73.4 \pm 3.6^\circ\text{F}$ ) and  $50 \pm 5\%$  relative humidity unless otherwise specified in the test method.

**10. Procedure**

10.1 With the probe apparatus installed, calibrate the test equipment following the manufacturer's instructions.

10.2 Select an equipment load range so that specimen puncture occurs within 20 to 80 % of the same.

10.3 Using the template and specimen cutter, prepare a minimum of five specimens from each sample.

10.4 Measure the caliper (average of three readings) in the center of each specimen and record the average.

10.5 Set universal tester crosshead speed at 10 in./min (250 mm/min) and chart recorder speed at 10 in./min (250 mm/min). If using an integrator instead of a data acquisition system, set the counters to zero.

10.6 Clamp the specimen in the holder. Lower the probe as close as possible to the specimen without actually touching.

10.7 Set the appropriate stops and returns on the universal tester. Reset data collection devices if applicable.

10.8 Activate the universal tester. Stop the crosshead when the puncture probe passes completely through the film. Where holes occur other than at the probe point, the specimen test results should be discarded. See **Fig. 3**.

10.9 Record specimen identification, peak force at break, maximum force, energy (work) to break, and probe penetration