



# SLOVENSKI STANDARD SIST ETS 300 902 E5:2003

01-december-2003

---

8 [[ ]HJb]`WV] b]`hY`Y`\_ca i b]\_UW`g\_]`g]ghYa `fZuU&ZL`E`HY b] bUfYU]nUW`Ugfcf]Hj Y  
\_fUh\_] `gdcfc ]`fGA GL`E`nj YXVUg`WV] bc`fUX]cX]Z n]c`fGA G7 6 L`f] GA `\$' `(%z  
fUh`] ]WU) "-`%z]nXUU%- \*L

Digital cellular telecommunications system (Phase 2+) (GSM); Technical realization of Short Message Service Cell Broadcast (SMSCB) (GSM 03.41 version 5.9.1 Release 1996)

## iteh STANDARD PREVIEW (standards.iteh.ai)

[SIST ETS 300 902 E5:2003](https://standards.iteh.ai/catalog/standards/sist/9f9e1058-e339-4ddf-aa79-7954948761b7/sist-ets-300-902-e5-2003)

<https://standards.iteh.ai/catalog/standards/sist/9f9e1058-e339-4ddf-aa79-7954948761b7/sist-ets-300-902-e5-2003>

Ta slovenski standard je istoveten z: **ETS 300 902 Edition 5**

---

### **ICS:**

33.070.50	Globalni sistem za mobilno telekomunikacijo (GSM)	Global System for Mobile Communication (GSM)
-----------	---------------------------------------------------	----------------------------------------------

**SIST ETS 300 902 E5:2003**

**en**

**iTeh STANDARD PREVIEW**  
**(standards.iteh.ai)**

SIST ETS 300 902 E5:2003

<https://standards.iteh.ai/catalog/standards/sist/9f9e1058-e339-4ddf-aa79-7954948761b7/sist-ets-300-902-e5-2003>



**E**UROPEAN  
**T**ELECOMMUNICATION  
**S**TANDARD

**ETS 300 902**

February 1999

Fifth Edition

Source: SMG

Reference: RE/SMG-040341QR7

ICS: 33.020

**Key words:** Digital cellular telecommunications system, Global System for Mobile communications (GSM)

**GSM**®

iTeh STANDARD PREVIEW  
(standardsite)

GLOBAL SYSTEM FOR

(MOBILE COMMUNICATIONS)

**Digital cellular telecommunications system (Phase 2+);  
Technical realization of Short Message Service  
Cell Broadcast (SMSCB)  
(GSM 03.41 version 5.9.1 Release 1996)**

**ETSI**

European Telecommunications Standards Institute

**ETSI Secretariat**

**Postal address:** F-06921 Sophia Antipolis CEDEX - FRANCE

**Office address:** 650 Route des Lucioles - Sophia Antipolis - Valbonne - FRANCE

**Internet:** secretariat@etsi.fr - <http://www.etsi.org>

Tel.: +33 4 92 94 42 00 - Fax: +33 4 93 65 47 16

**Copyright Notification:** No part may be reproduced except as authorized by written permission. The copyright and the foregoing restriction extend to reproduction in all media.

© European Telecommunications Standards Institute 1998. All rights reserved.

**iTeh STANDARD PREVIEW**  
**(standards.iteh.ai)**

[SIST ETS 300 902 E5:2003](https://standards.iteh.ai/catalog/standards/sist/9f9e1058-e339-4ddf-aa79-7954948761b7/sist-ets-300-902-e5-2003)

<https://standards.iteh.ai/catalog/standards/sist/9f9e1058-e339-4ddf-aa79-7954948761b7/sist-ets-300-902-e5-2003>

## Contents

Foreword .....	5
1 Scope .....	7
1.1 Normative references .....	7
1.2 Abbreviations .....	7
2 General description .....	8
3 Network Architecture .....	9
4 CBE Functionality .....	9
5 CBC Functionality .....	9
6 BSC Functionality .....	10
7 BTS Functionality .....	10
8 MS Functionality .....	11
9 Protocols and Protocol Architecture .....	11
9.1 CBC-BSC Primitives .....	13
9.1.1 Identification of a message .....	13
9.1.2 WRITE-REPLACE Request/Indication .....	14
9.1.3 KILL Request/Indication .....	16
9.1.4 REPORT Response/Confirm .....	16
9.1.5 STATUS-CBCH-QUERY Request/Indication .....	16
9.1.6 STATUS-CBCH-QUERY Response/Confirm .....	16
9.1.7 STATUS-MESSAGE-QUERY Request/Indication .....	17
9.1.8 STATUS-MESSAGE-QUERY Response/Confirm .....	17
9.1.9 REJECT Response/Confirm .....	17
9.1.10 RESTART-INDICATION Request/Indication .....	17
9.1.11 RESET Request/Indication .....	18
9.1.12 FAILURE-INDICATION Request/Indication .....	18
9.1.13 SET-DRX Request/Indication .....	18
9.1.14 SET-DRX- REPORT Response/Confirm .....	19
9.2 Parameters .....	19
9.2.1 Message-Identifier .....	19
9.2.2 Old-Serial-Number .....	19
9.2.3 New-Serial-Number .....	19
9.2.4 Number-of-Pages .....	19
9.2.5 Cell-List .....	19
9.2.5.1 Cell-List sent from CBC to BSC .....	20
9.2.5.2 Cell-List sent from BSC to CBC .....	20
9.2.6 Channel Indicator .....	20
9.2.7 Category .....	20
9.2.8 Repetition-Period .....	20
9.2.9 No-of-Broadcasts-Requested .....	21
9.2.10 No-of-Broadcasts-Completed-List .....	21
9.2.11 Cell-Identifier .....	21
9.2.12 Schedule-Period .....	22
9.2.13 Reserved-Slots .....	22
9.2.14 Failure-List .....	22
9.2.15 CBCH-Loading-List .....	22
9.2.16 Cause .....	23
9.2.17 Diagnostic .....	23

9.2.18	Data Coding Scheme.....	23
9.2.19	CBS-Message-Information-Page n.....	24
9.2.20	CBS-Message-Information-Length n.....	24
9.2.21	Recovery-Indication .....	24
9.3	Message Format on BTS-MS Interface .....	24
9.3.1	General Description .....	24
9.3.2	Message Content.....	24
9.4	CBS Compression.....	27
10	SMSCB Index .....	27
Annex A (informative):	Protocols for interconnecting CBC and BSC .....	29
Annex B (informative):	Document change history .....	30
History .....		32

## iTeh STANDARD PREVIEW (standards.iteh.ai)

[SIST ETS 300 902 E5:2003](https://standards.iteh.ai/catalog/standards/sist/99e1058-e339-4ddf-aa79-7954948761b7/sist-ets-300-902-e5-2003)

<https://standards.iteh.ai/catalog/standards/sist/99e1058-e339-4ddf-aa79-7954948761b7/sist-ets-300-902-e5-2003>

## Foreword

This fifth edition European Telecommunications Standard (ETS) has been produced by the Special Mobile Group (SMG) of the European Telecommunications Standards Institute (ETSI).

This ETS defines the Cell Broadcast short message service (CBS). It defines the primitives over the Cell Broadcast Centre - Base Station System (CBC-BSS) interface and the message formats over the Base Station System - Mobile Station (BSS-MS) interface for Teleservice 23 within the digital cellular telecommunications system (Phase 2+).

The contents of this ETS is subject to continuing work within SMG and may change following formal SMG approval. Should SMG modify the contents of this ETS, it will be resubmitted for OAP by ETSI with an identifying change of release date and an increase in version number as follows:

Version 5.x.y

where:

- 5 indicates GSM Phase 2+ Release 1996
- x the second digit is incremented for all other types of changes, i.e. technical enhancements, corrections, updates, etc.
- y the third digit is incremented when editorial only changes have been incorporated in the specification.

<b>Transposition dates</b>	
Date of adoption of this ETS:	11 December 1998
Date of latest announcement of this ETS (doa):	31 March 1999
Date of latest publication of new National Standard or endorsement of this ETS (dop/e):	30 September 1999
Date of withdrawal of any conflicting National Standard (dow):	30 September 1999

Blank page

**iTeh STANDARD PREVIEW**  
**(standards.iteh.ai)**

[SIST ETS 300 902 E5:2003](https://standards.iteh.ai/catalog/standards/sist/9f9e1058-e339-4ddf-aa79-7954948761b7/sist-ets-300-902-e5-2003)

<https://standards.iteh.ai/catalog/standards/sist/9f9e1058-e339-4ddf-aa79-7954948761b7/sist-ets-300-902-e5-2003>



## 1 Scope

This European Telecommunications Standard (ETS) describes the Cell Broadcast short message service (CBS). It defines the primitives over the Cell Broadcast Centre - Base Station System (CBC-BSS) interface and the message formats over the Base Station System - Mobile Station (BSS-MS) interface for Teleservice 23 as specified in GSM 02.03 [2].

### 1.1 Normative references

This ETS incorporates by dated and undated reference, provisions from other publications. These normative references are cited at the appropriate places in the text and the publications are listed hereafter. For dated references, subsequent amendments to or revisions of any of these publications apply to this ETS only when incorporated in it by amendment or revision. For undated references, the latest edition of the publication referred to applies.

- [1] GSM 01.04 (ETR 350): "Digital cellular telecommunication system (Phase 2+); Abbreviations and acronyms".
- [2] GSM 02.03 (ETS 300 905): "Digital cellular telecommunication system (Phase 2+); Teleservices supported by a GSM Public Land Mobile Network (PLMN)".
- [3] GSM 03.38 (ETS 300 900): "Digital cellular telecommunication system (Phase 2+); Alphabets and language-specific information".
- [4] GSM 03.40 (ETS 300 901): "Digital cellular telecommunication system (Phase 2+); Technical realization of the Short Message Service (SMS) Point to Point (PP)".
- [5] GSM 03.47 (ETR 354): "Digital cellular telecommunication system; Example protocol stacks for interconnecting Service Centre(s) (SC) and Mobile-services Switching Centre(s) (MSC)".
- [6] GSM 03.49: "Digital cellular telecommunication system (Phase 2+); Example protocol stacks for interconnecting Cell Broadcast Centre (CBC) and Mobile-services Switching Centre (MSC)".
- [7] GSM 04.12 (ETS 300 943): "Digital cellular telecommunication system (Phase 2+); Short Message Service Cell Broadcast (SMSCB) support on the mobile radio interface".
- [8] GSM 05.02 (ETS 300 908): "Digital cellular telecommunication system (Phase 2+); Multiplexing and multiple access on the radio path".
- [9] GSM 07.05: "Digital cellular telecommunication system (Phase 2+); Use of Data Terminal Equipment - Data Circuit terminating Equipment (DTE - DCE) interface for Short Message Service (SMS) and Cell Broadcast Service (CBS)".
- [10] GSM 08.52: "Digital cellular telecommunication system; Base Station Controller - Base Transceiver Station (BSC - BTS) interface Interface principles".
- [11] GSM 08.58: "Digital cellular telecommunication system (Phase 2+); Base Station Controller - Base Transceiver Station (BSC - BTS) interface Layer 3 specification".
- [12] CCITT Recommendation X.210: "Open systems interconnection layer service definition conventions".

### 1.2 Abbreviations

Abbreviations used in this ETS are listed in GSM 01.04 [1].

## 2 General description

The CBS service is analogous to the Teletex service offered on television, in that like Teletex, it permits a number of unacknowledged general messages to be broadcast to all receivers within a particular region. CBS messages are broadcast to defined geographical areas known as cell broadcast areas. These areas may comprise of one or more cells, or may comprise the entire PLMN. Individual CBS messages will be assigned their own geographical coverage areas by mutual agreement between the information provider and the PLMN operator. CBS messages may originate from a number of Cell Broadcast Entities (CBEs), which are connected to the Cell Broadcast Centre. CBS messages are then sent from the CBC to the BTSs, in accordance with the CBS's coverage requirements.

The CBS message comprises of 82 octets, which, using the default character set, equates to 93 characters. Up to 15 of these messages (pages) may be concatenated to form a macromessage. Each page of such macromessages will have the same message identifier (indicating the source of the message), and the same serial number. Using this information, the MS is able to identify and ignore re-broadcasts of already received messages.

CBS messages are broadcast cyclically by the BTS at a frequency and for a duration specified by the information provider. The frequency at which messages are repeatedly transmitted will be dependent on the information that they contain; for example, it is likely that dynamic information such as road traffic information, will require more frequent transmission than weather information. The repetition period will also be affected by the desire for messages to be received by high speed mobiles which rapidly traverse cells. All suitably equipped mobiles within the catchment area of the transmitting BTS will be able to receive the broadcast messages, provided that they are switched on and in the idle state.

CBS messages may be broadcast on two different cell broadcast channels, which are characterized by different QoS. A MS is always able to read the basic channel (see [8]). The reading of the extended channel may collide with other tasks of the MS. Therefore the probability of receiving a CBS message on the extended channel is smaller than on the basic channel. The reading of the extended channel for MSs is optional. The scheduling on the channels will be done independently.

To permit mobiles to selectively display only those messages required by the MS user, CBS messages are assigned a message class which categorises the type of information that they contain and the language in which the message has been compiled. Through the use of appropriate MMI, the user is then able to ignore message types that he does not wish to receive, e.g. advertising information or messages in an unfamiliar language.

### 3 Network Architecture

The basic network structure of CBS is depicted by figure 1.

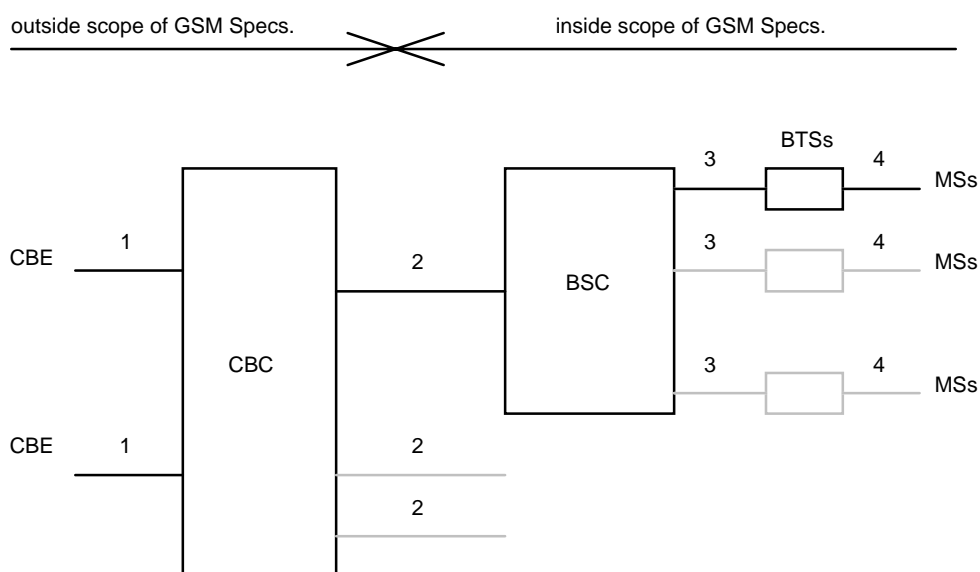

Figure 1

- message transfer on link 1 is outside the scope of GSM Specifications;
- message transfer on link 2 is described in Section 9.1;
- message transfer on link 3 is described in GSM 08.58;
- message transfer on link 4 is described in GSM 04.12 and the timing of messages transferred on link 4 is described in GSM 05.02.

### 4 CBE Functionality

The functionality of the CBE is outside of the scope of GSM Specifications; however it is assumed that the CBE is responsible for all aspects of formatting CBS, including the splitting of a CBS message into a number of pages.

### 5 CBC Functionality

As the CBC (and any originating point for cell broadcast short messages) is regarded as a node outside the PLMN, only the requirements placed upon the CBC by CBS functionality are specified by this specification.

The CBC may be connected to several BSCs. The CBC may be connected to several CBEs. The CBC shall be responsible for the management of cell broadcast short messages including:

- allocation of serial numbers;
- modifying or deleting messages held by the BSC;
- initiating broadcast by sending fixed length cell broadcast short messages to a BSC for each language provided by the cell, and where necessary padding the message with the appropriate character to a length of 82 octets;
- determining the set of cells/BTSs to which a message should be broadcast, and indicating within the Serial Number the geographical scope of each message;
- determining the time at which a message should commence being broadcast;

- determining the time at which a message should cease being broadcast and subsequently instructing each BSC to cease broadcast of the message;
- determining the period at which broadcast of the message should be repeated;
- determining the cell broadcast channel, on which the message should be broadcast.

To work efficiently on the interfaces, the BSC - which is normally controlling more than one cell of a broadcast area - should be used as a concentrator as far as CB message handling is concerned. Hence, the CBC should work on lists of cells when issuing CB related requests towards the BSC.

## 6 BSC Functionality

The BSC shall interface to only one CBC. A BSC may interface to several BTSs as indicated by GSM 08.52. The BSC shall be responsible for:

- interpretation of commands from the CBC;
- storage of cell broadcast messages;
- scheduling of cell broadcast messages on the CBCH;
- providing an indication to the CBC when the desired repetition period cannot be achieved;
- providing to the CBC acknowledgement of successful execution of commands received from the CBC;
- reporting to the CBC failure when a command received from the CBC is not understood or cannot be executed;
- routing cell broadcast messages to the appropriate BTSs;
- transferring CBS information to each appropriate BTS via a sequence of 4 SMS BROADCAST REQUEST messages or 1 SMS BROADCAST COMMAND message (see GSM 08.58), indicating the channel which shall be used.
- optionally generating Schedule Messages, indicating the intended schedule of transmissions (see GSM 04.12);
- optionally receiving CBCH Load Indication messages and reacting by broadcasting a burst of scheduled SMSCB messages or by suspending the broadcast for a period indicated by BTS (see GSM 08.58);

To work efficiently on the interfaces, the BSC should forward CB related messages to the CBC using cell lists as far as applicable.

## 7 BTS Functionality

The BTS is responsible for conveying CBS information received via SMS BROADCAST REQUEST or SMS BROADCAST COMMAND messages over the radio path to the MS.

- optionally generating CBCH Load Indication messages, indicating an underflow or overflow situation on the CBCH (see GSM 08.58).