Vozila za talni transport - Gnana vozila za talni transport - Vidno polje voznika - Preskusne metode in preverjanje - 5. del: Vozila za talni transport s spremenljivim dosegom in z zmogljivostjo, večjo od 10 000 kg

Powered industrial trucks - Visibility - test methods and verification - Part 5: Industrial variable-reach trucks greater than 10 000 kg capacity

Kraftbetriebene Flurförderzeuge - Sichtverhältnisse - Prüfverfahren und Verifikation - Teil 5: Flurförderzeuge mit veränderlicher Reichweite mit einer Nenntragfähigkeit größer 10 000 kg
(standards.iteh.ai)

Chariots de manutention - Visibilité - Méthode d'essai pour la vérification - Partie 5 : Chariots de manutention à portée variable ayant une capacité supérieure à 10 000 kg
SIST EN 16842-5:2021
https://standards.iteh.ai/catalog/standards/sist/0517c2e0-9245-49c9-ag2a-487bd1daba9/sist-en-16842-5-2021

Ta slovenski standard je istoveten z: EN 16842-5:2021

ICS:

53.060 Industrijski tovornjaki Industrial trucks

SIST EN 16842-5:2021

en,fr,de

iTeh STANDARD PREVIEW
(standards.iteh.ai)

SIST EN 16842-5:2021

<https://standards.iteh.ai/catalog/standards/sist/0517c2e0-9245-49c9-ac2a-487bdfidaba9/sist-en-16842-5-2021>

EUROPEAN STANDARD

EN 16842-5

NORME EUROPÉENNE

EUROPÄISCHE NORM

January 2021

ICS 53.060

English Version

Powered industrial trucks - Visibility - Test methods and verification - Part 5: Industrial variable-reach trucks greater than 10 000 kg capacity

Chariots de manutention automoteurs - Visibilité -
Méthodes d'essai et vérification - Partie 5 : Chariots de
manutention à portée variable ayant une capacité
supérieure à 10 000 kg

Kraftbetriebene Flurförderzeuge - Sichtverhältnisse -
Prüfverfahren und Verifikation - Teil 5:
Flurförderzeuge mit veränderlicher Reichweite mit
einer Nenntragfähigkeit größer 10 000 kg

This European Standard was approved by CEN on 6 December 2020.

CEN members are bound to comply with the CEN/CENELEC Internal Regulations which stipulate the conditions for giving this European Standard the status of a national standard without any alteration. Up-to-date lists and bibliographical references concerning such national standards may be obtained on application to the CEN-CENELEC Management Centre or to any CEN member.

This European Standard exists in three official versions (English, French, German). A version in any other language made by translation under the responsibility of a CEN member into its own language and notified to the CEN-CENELEC Management Centre has the same status as the official versions.

CEN members are the national standards bodies of Austria, Belgium, Bulgaria, Croatia, Cyprus, Czech Republic, Denmark, Estonia, Finland, France, Germany, Greece, Hungary, Iceland, Ireland, Italy, Latvia, Lithuania, Luxembourg, Malta, Netherlands, Norway, Poland, Portugal, Republic of North Macedonia, Romania, Serbia, Slovakia, Slovenia, Spain, Sweden, Switzerland, Turkey and United Kingdom.



EUROPEAN COMMITTEE FOR STANDARDIZATION
COMITÉ EUROPÉEN DE NORMALISATION
EUROPÄISCHES KOMITEE FÜR NORMUNG

CEN-CENELEC Management Centre: Rue de la Science 23, B-1040 Brussels

Contents	Page
European foreword	3
Introduction	5
1 Scope	6
2 Normative references	6
3 Terms and definitions	6
4 Truck configuration	6
4.1 General	6
4.2 Height of load carrying surface	6
4.3 Fork arm dimension	7
4.4 Retractable lift boom position	7
5 Test equipment	7
6 Test procedures for direct visibility	7
6.1 Lighting equipment position	7
6.2 Test paths for industrial variable reach trucks > 10 000 kg capacity	8
6.3 Measurement procedure	9
6.4 Test procedure for indirect visibility	10
7 Acceptance criteria	10
7.1 General	10
7.2 Direct visibility	10
7.3 Indirect visibility	10
7.4 Criteria for industrial variable-reach trucks greater than 10 000 kg rated capacity	11
8 Test report	12
9 Information for use	12

European foreword

This document (EN 16842-5:2021) has been prepared by Technical Committee CEN/TC 150 “Industrial trucks – Safety”, the secretariat of which is held by BSI.

This European Standard shall be given the status of a national standard, either by publication of an identical text or by endorsement, at the latest by July 2021, and conflicting national standards shall be withdrawn at the latest by July 2021.

Attention is drawn to the possibility that some of the elements of this document may be the subject of patent rights. CEN shall not be held responsible for identifying any or all such patent rights.

This document is intended to be used in combination with the requirements in EN 16842-1.

The EN 16842 series consists of the following parts under the general title “*Powered industrial trucks – Visibility – Test methods and verification*”:

- *Part 1: General requirements;*
- *Part 2: Sit-on counterbalance trucks and rough terrain masted trucks up to and including 10 000 kg capacity;*
- *Part 3: Reach trucks up to and including 10 000 kg capacity;*
- *Part 4: Industrial variable reach trucks up to and including 10 000 kg capacity;*
- *Part 5: Industrial variable reach trucks greater than 10 000 kg capacity;*
- *Part 6: Sit-on counterbalance trucks and rough terrain masted trucks greater than 10 000 kg capacity;*
- *Part 7: Variable reach and masted container trucks handling freight containers of 6 m (20 ft) length and longer;*
- *Part 8: Stand on counterbalance trucks up to and including 10 000 kg capacity;*
- *Part 9: Order picking lateral- and front stacking trucks with elevating operator position;*
- *Part 10: Towing and Pushing tractors and Burden carrier.*

It is intended to develop the parts related to the following machinery:

- Pallet stacking trucks (rider controlled);
- Single side loader;
- Multi-directional forklift truck;
- Articulated counterbalance lift truck;
- Non-stacking low-lift straddle carrier (as defined in ISO 5053-1:2020, 3.18);
- Stacking high-lift straddle carrier (as defined in ISO 5053-1:2020, 3.19).

EN 16842-5:2021 (E)

According to the CEN-CENELEC Internal Regulations, the national standards organisations of the following countries are bound to implement this European Standard: Austria, Belgium, Bulgaria, Croatia, Cyprus, Czech Republic, Denmark, Estonia, Finland, France, Germany, Greece, Hungary, Iceland, Ireland, Italy, Latvia, Lithuania, Luxembourg, Malta, Netherlands, Norway, Poland, Portugal, Republic of North Macedonia, Romania, Serbia, Slovakia, Slovenia, Spain, Sweden, Switzerland, Turkey and the United Kingdom.

**iTeh STANDARD PREVIEW
(standards.iteh.ai)**

[SIST EN 16842-5:2021](https://standards.iteh.ai/catalog/standards/sist/0517c2e0-9245-49c9-ac2a-487bdfddaba9/sist-en-16842-5-2021)

<https://standards.iteh.ai/catalog/standards/sist/0517c2e0-9245-49c9-ac2a-487bdfddaba9/sist-en-16842-5-2021>

Introduction

This document is a Type-C standard as stated in EN ISO 12100.

This document is of relevance, in particular, for the following stakeholder groups representing the market players with regard to machinery safety:

- machine manufacturers (small, medium and large enterprises);
- health and safety bodies (regulators, accident prevention organizations, market surveillance, etc.).

Others can be affected by the level of machinery safety achieved with the means of the document by the above-mentioned stakeholder groups:

- machine users/employers (small, medium and large enterprises);
- machine users/employees (e.g. trade unions, organizations for people with special needs);
- service providers, e.g. for maintenance (small, medium and large enterprises);
- consumers (in case of machinery intended for use by consumers).

The above-mentioned stakeholder groups have been given the possibility to participate at the drafting process of this document.

The machinery concerned and the extent to which hazards, hazardous situations or hazardous events are covered are indicated in the Scope of this document.

When requirements of this type-C standard are different from those which are stated in type-A or type-B standards, the requirements of this type-C standard take precedence over the requirements of the other standards for machines that have been designed and built according to the requirements of this type-C standard.

EN 16842-5:2021 (E)**1 Scope**

This document specifies the requirements and test procedures for 360° visibility of sit on self-propelled industrial variable-reach trucks (herein after referred to as trucks) without a load, with a capacity greater than 10 000 kg in accordance with ISO 5053-1. It is intended to be used in conjunction with EN 16842-1.

Where specific requirements in this part are modified from the general requirements in EN 16842-1, the requirements of this part are truck specific and to be used for sit-on self-propelled industrial variable-reach trucks with a capacity greater than 10 000 kg.

This part of EN 16842 deals with all significant hazards, hazardous situations or hazardous events, relevant to the visibility of the operator for applicable machines when used as intended and under conditions of misuse which are reasonably foreseeable by the manufacturer.

This document does not deal with rough-terrain variable-reach trucks (see EN 15830).

2 Normative references

The following documents are referred to in the text in such a way that some or all of their content constitutes requirements of this document. For dated references, only the edition cited applies. For undated references, the latest edition of the referenced document (including any amendments) applies.

EN 16842-1:2018, *Powered industrial trucks - Visibility - Test methods and verification - Part 1: General requirements*

EN ISO 3691-2:2016¹⁾, *Industrial trucks - Safety requirements and verification - Part 2: Self-propelled variable-reach trucks (ISO 3691-2:2016)*

ISO 5053-1:2020, *Industrial trucks - Vocabulary - Part 1: Types of industrial trucks*

SIST EN 16842-5:2021

<https://standards.iteh.ai/catalog/standards/sist/0517c2e0-9245-49c9-ac2a-487bdfdfaba9/sist-en-16842-5-2021>

3 Terms and definitions

For the purposes of this document, the terms and definitions given in EN 16842-1:2018, EN ISO 3691-2:2016¹⁾ and ISO 5053-1:2020 apply.

ISO and IEC maintain terminological databases for use in standardization at the following addresses:

- IEC Electropedia: available at <http://www.electropedia.org/>
- ISO Online browsing platform: available at <https://www.iso.org/obp>

4 Truck configuration**4.1 General**

For truck test configuration, EN 16842-1:2018, 4.1 and 4.2.2 shall apply.

4.2 Height of load carrying surface

The load carrying surface of the fork arms, measured at the heel shall be positioned up to 500 mm above the floor.

NOTE The dimensions above are to enable the operator to adjust height of the forks for maximum visibility of fork tips.

1) As impacted by EN ISO 3691-2:2016/AC:2016.

4.3 Fork arm dimensions

The test truck shall be equipped with fork arms of the following nominal lengths:

- Trucks with load centre 600 mm, fork arm length 1 200 mm;
- Trucks with load centre 900 mm, fork arm length 1 800 mm;
- Trucks with load centre 1 200 mm, fork arm length 2 400 mm.

Other fork arm lengths shall be tested if these adversely affect visibility (e.g. shorter fork arms).

Lengths of forks arms shall be noted in the test report in accordance with Clause 8.

NOTE Fork arm lengths in millimetres are given as two times the length of the standard load centre distance as defined in EN ISO 3691-2:2016, A.3.1.

4.4 Retractable lift boom position

Where applicable, any reaching/telescopic mechanism is to be fully retracted.

5 Test equipment

For test equipment, EN 16842-1:2018, Clause 5 shall apply.

6 Test procedures for direct visibility

6.1 Lighting equipment position

6.1.1 Sit-on operated trucks

The lighting equipment shall be positioned relative to the seat index point (SIP). The seat shall be placed at the closest adjustment position to the mid-point of horizontal and vertical adjustment and the mid-point of the suspension height, if so equipped (see Figure 1).

EN 16842-5:2021 (E)

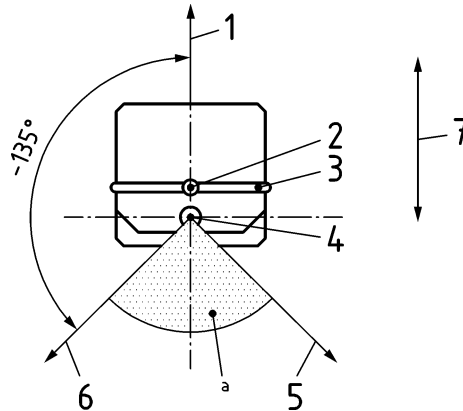

Sit-on trucks where the operator is facing the line of travel

Key

1	0° seat direction	5	+135° test direction
2	SIP	6	-135° test direction
3	row of lights	7	forward and rearward truck direction for all seat positions shown
4	row of lights axis of rotation		
a	the row of lights cannot be turned to this area for tests		

Figure 1 — Seat position and test direction

6.2 Test paths for industrial variable reach trucks > 10 000 kg capacity

Test paths P1 to P9 (see Figure 2) shall consist of lines laid out on the floor around the test truck, parallel or perpendicular to the truck longitudinal axis. The distance between truck profile, as defined in EN 16842-1:2018, 3.1 and the test paths are specified in Figure 2.