



Designation: D 5767 – 95 (Reapproved 1999)

Standard Test Methods for Instrumental Measurement of Distinctness-of-Image Gloss of Coating Surfaces¹

This standard is issued under the fixed designation D 5767; the number immediately following the designation indicates the year of original adoption or, in the case of revision, the year of last revision. A number in parentheses indicates the year of last reapproval. A superscript epsilon (ϵ) indicates an editorial change since the last revision or reapproval.

1. Scope

1.1 This test method describes the measurement of the distinctness-of-image (DOI) gloss of coating surfaces using electro-optical measuring techniques. The coatings must be applied to planar rigid surfaces. The scale values obtained from the alternative methods cited do not agree.

1.2 Three test methods are covered as follows:

1.2.1 *Test Method A*—Gloss reflectance factor measurements are made on the specimen at the specular viewing angle and at an angle slightly off the specular viewing angle. The values obtained are combined to provide a DOI value. Very narrow source and receptor aperture angles are used in the measurements.

1.2.2 *Test Method B*—The light through a small slit is projected on the specimen surface and its reflected image intensity is measured through a sliding combed shutter to provide a value of image clarity.

1.2.3 *Test Method C*—The light through a pattern is projected on the specimen surface and its reflected image intensity is measured directly to provide a value of image clarity.

1.3 *This standard does not purport to address all of the safety concerns, if any, associated with its use. It is the responsibility of whoever uses this standard to consult and establish appropriate safety and health practices and determine the applicability of regulatory limitations prior to use.*

2. Referenced Documents

2.1 ASTM Standards:

- D 523 Test Method for Specular Gloss²
- D 823 Practices for Producing Films of Uniform Thickness and Related Products on Test Panels²
- D 2457 Test Method for Specular Gloss of Plastic Films and Solid Plastics³
- D 3964 Practice for Selection of Coating Specimens for Appearance Measurements²
- D 4039 Test Method for Reflection Haze of High-Gloss Surfaces²

¹ These test methods are under the jurisdiction of ASTM Committee D-1 on Paint and Related Coatings, Materials, and Applications and is the direct responsibility of Subcommittee D01.26 on Optical Properties.

Current edition approved Sept. 15, 1995. Published November 1995.

² *Annual Book of ASTM Standards*, Vol 06.01.

³ *Annual Book of ASTM Standards*, Vol 08.02.

E 284 Terminology of Appearance²

E 430 Test Methods for Measurement of Gloss of High-Gloss Surfaces by Goniophotometry²

2.2 Other Standards:

ISO 10216 Anodized Aluminum and Aluminum Alloys—Instrumental Determination of Image Clarity of Anodic Oxidation Coatings—Instrumental Method⁴

3. Terminology

3.1 Terms and Definitions in Terminology E 284 are applicable to these methods.

3.2 Definitions:

3.2.1 *distinctness-of-image gloss, n*—aspect of gloss characterized by the sharpness of images of objects produced by reflection at a surface (E 284).

3.2.1.1 *Discussion*—This quality is sometimes called Image Clarity.

3.2.2 *gloss reflectance factor, R_s, n*—ratio of the specularly reflected part of the (whole) flux reflected from the specimen to the flux reflected from a specified gloss standard under the same geometric and spectral conditions of measurements (E 284).

3.2.2.1 *Discussion*—The gloss standard may be a black glass or mirror and may be assigned one of a variety of scale values as specified.

3.2.3 *specular angle, n*—the angle of reflection equal and opposite to the angle of incidence (E 284).

4. Significance and Use

4.1 An important aspect of the appearance of glossy coating surfaces is the distinctness (clarity) of images reflected by them. The values obtained by the measuring procedures given in these methods generally correlate well with visual ratings for DOI (image clarity).⁵

4.2 Although Test Methods D 523 and D 4039 are useful in characterizing some aspects of glossy appearance, they do not provide satisfactory ratings for DOI (image clarity).

4.3 The measurement conditions given conform to the conditions specified in Test Methods E 430.

⁴ Available from ANSI, 11 W. 42nd St., 13th Floor, New York, NY 10036.

⁵ Supporting data are available from ASTM Headquarters. Request RR: D01-1092.

4.4 The measurement conditions given in Test Methods B and C conform to the conditions specified in ISO Standard #10216.

4.5 The scale values obtained with the measuring procedures of these methods range from 0 to 100 with a value of 100 representing perfect DOI (image clarity).

4.6 The DOI (image clarity) scale value does not of itself, indicate any specific cause for reduction in reflected image sharpness. Surface irregularities such as haze, orange peel, and wrinkle, when present, may be cited as causes for reduction of image sharpness.

5. Preparation and Selection of Test Specimens

5.1 These test methods do not cover techniques for the preparation of test specimens. Whenever preparation of test specimens is required, use one of the procedures given in Practices D 823. Selection of specimens for measurement should be done in accordance with Practice D 3964.

6. Correlation of Results of Test Methods A, B and C to Visual Perception of Image Distinction of Coating Surfaces

6.1 An analysis of the results of a round robin conducted by Task Group D 01.26.11 demonstrates the level of correlation between instruments currently included in these test methods and with visual perception.⁵

TEST METHOD A

7. Apparatus

7.1 *Abridged Goniophotometer or Gonioreflectometer*, which can be set to the beam and aperture angles indicated in Table 1.

7.1.1 *Geometric Conditions*—The axis of the incident beam shall be 20 or 30° from the perpendicular to the specimen surface. Provisions shall be made so that receptor settings will be at the specular angle and at an angle of 0.2 to 0.4° off the specular angle. Suitable angular dimensions of the image of the source aperture and angular dimensions of the receptor apertures are given in Table 1.

7.1.2 *Spectral Conditions*—The measurement shall be made with visible radiation (light) to give results in accordance with the CIE spectral luminous efficiency.

7.1.3 *Polarization*—The incident flux shall be unpolarized and the receptor shall be insensitive to the state of polarization of the reflected luminous flux.

TABLE 1 Angles and Dimensions of Source Image and Receptors

	Dimensions of Source Image at Sample Plane, °	Dimensions of the Viewed Area at Sample Plane, °	Dimensions of the Viewed Area DOI, °
Center of window	20 or 30	20 or 30	0.3 ± 0.1
Width ^A	0.44	0.38	0.14
Length ^B	7.0	4.0	4.0

^AIn plane of the angle of reflection.

^BAcross the plane of the angle of reflection.

8. Reference Standards

8.1 *Primary Standard*—Highly polished, planar black glass with a refractive index of 1.567 for the Sodium D Line shall be assigned a G_s value of 100 on the instrument reading scale.

8.2 *Working Standard (Intermediate-Scale Standard)*—Highly polished, planar black glass with a refractive index close to 1.527 may be used as a standard if its assigned value has been established by measurement against the primary standard or by computation from its refractive index using the Fresnel equation.

8.2.1 It shall be assigned a scale value of $G_s = 89.4$ for a specular angle of 30°, or $G_s = 89.2$ for a specular angle of 20°.

NOTE 1—Each 0.01 increment in index of refraction produces a change of approximately 3 units in the assigned scale value of polished black glass for 20° geometry and a change of approximately 2.5 units in the assigned scale value for 30° geometry.

NOTE 2—To determine the scale value, calculate the first surface (Fresnel) reflectance (see Test Method D 2457, 5.1) for $n_D = 1.567$ and the specular angle of interest; for 30° it is 5.0436 % and for 20° it is 4.90 %. Assign this a scale value of 100 (see Test Method D 523, 7.1). Repeat the calculation for $n_D = 1.527$ and the same specular angle; the result for 30° is 4.5069 % and for 20°, 4.3769 %. The new scale value for 30° is $100 \times (4.5069/5.0436) = 89.4$, and for 20°, $100 \times (4.3769/4.9078) = 89.2$. (The latter figure is identical to that given in Test Method D 523 for the same angle.)

8.3 *Verification Standards*—Depolished opaque black glass and ceramic tile having uniform, planar surfaces are suitable when calibrated against a primary or working standard on an abridged goniophotometer or gonioreflectometer known to meet the requirements of Test Method A.

9. Standardization of Apparatus

9.1 Adjust the instrument to read the assigned scale value of the polished black glass standard. Take readings on verification standards whose assigned values cover the range of the instrument scale. The readings of the verification standards should agree within ±1 unit of their assigned values.

10. Procedure

10.1 Position the specimen on the instrument. Place a clamp or weight on the specimen to flatten it. Take a reading, R_s , at the specular angle. Without moving the specimen, take a reading, R_{os} , at a receptor angle of 0.2 to 0.4° off the specular angle.

10.2 Repeat this procedure on at least two other areas of the specimen.

10.3 Take readings on the standards at the end of the series of specimen readings to ensure that the instrument has remained in calibration throughout the operation.

11. Calculation

11.1 Combine the specular angle reading, R_s , with the off specular reading, R_{os} , as follows:

$$DOI = [1 - (R_{os}/R_s)] \times 100 \quad (1)$$

NOTE 3—Some instruments perform this calculation internally and provide a direct reading of DOI.

12. Report

12.1 Report the following information:

12.1.1 R_s ,

- 12.1.2 R_{os} ,
- 12.1.3 Mean DOI,
- 12.1.4 Incident angle used, and
- 12.1.5 Instrument used.

13. Precision and Bias

13.1 *Precision*—Precision data are not available. When an interlaboratory test has been conducted, precision statements will be established from the test results.

13.2 *Bias*—Bias cannot be determined because there is no accepted reference procedure for determining true values.

TEST METHOD B

14. Apparatus

14.1 *Image Clarity Meter*, consisting of a light source, a sliding combed shutter, a photo-receiver, and a device for analyzing image intensities (see Fig. 1).

14.2 *Principle*—The light through a small slit is projected on the specimen surface, and its reflected image intensity through a sliding combed shutter is measured.

14.3 *Geometric Conditions*—The axis of the incident beam shall be 60° from the perpendicular to the specimen surface, and the photo-receiver shall be at the mirror reflection of the axis of the incident beam. The source slit is 0.1 ± 0.02 mm in width, and the photo-receiver shall receive a reflected image through a combed shutter of 18 slits of 7.5 mm in width.

NOTE 4—A more complete description of the spectral geometry of this instrument may be found in ISO 10216.⁶

15. Reference Standards

15.1 *Primary Standard*—Highly polished, planar black glass with refractive index of 1.567 for the Sodium D Line shall be assigned a value of 100 on the instrumental scale.

⁶ The sole source of supply of the meter Model HA-ICM, Image Clarity, known to the committee at this time is Suga Test Instruments Co., Ltd., 4-14, Shinjuku 5-chome, Shinjuku-ku, Tokyo, 160 Japan. If you are aware of alternative suppliers, please provide this information to ASTM Headquarters. Your comments will receive careful consideration at a meeting of the responsible technical committee,¹ which you may attend.

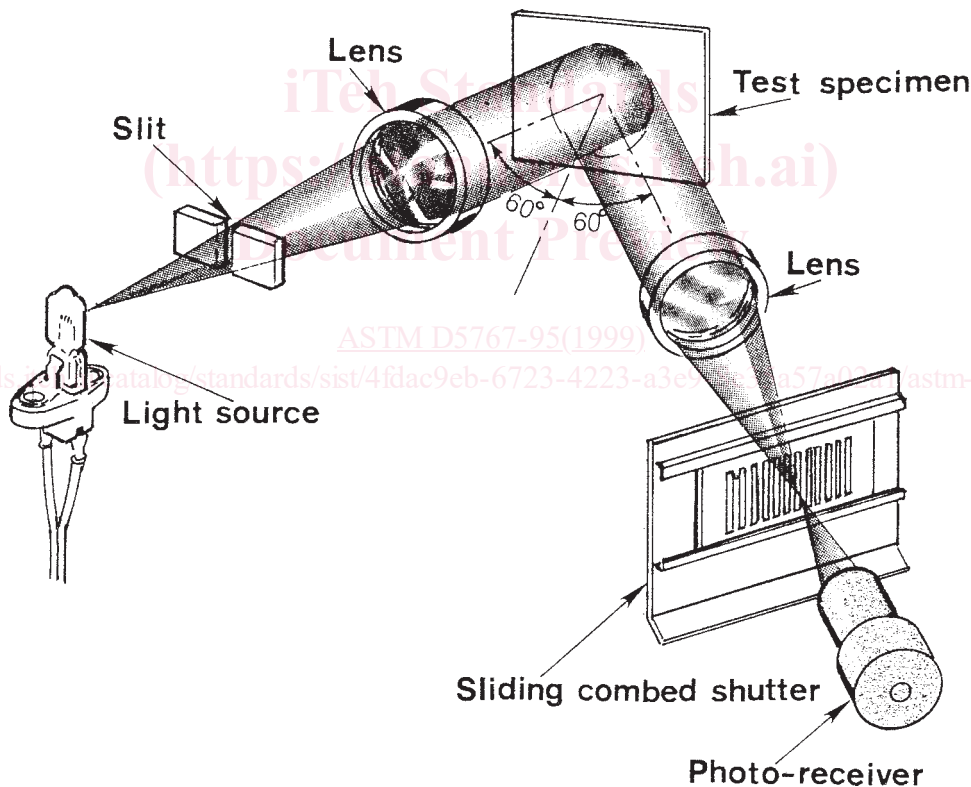

- DIMENSIONS HA-ICM
- A—Slit—0.1 mm
 - B—Light Angle— 22°
 - C—Slit/Lens Dist.—50 mm
 - D—Lens—f 50mm
 - E—Lens/Test Spec. Dist.—50 mm
 - F—Test Spec./Lens Dist.—50 mm
 - G—Lens—f 50 mm
 - H—Lens/Com. Shut. Dist.—50 mm
 - I—Light Angle— 22°
 - J—Shut./Slit Length—10 mm
 - K—Shut./Slit Width—0.5 mm
 - L—Shut./Slit Space—0.5 mm

FIG. 1 Testing Apparatus for Image Clarity Measurement