



# SLOVENSKI STANDARD

## oSIST prEN 12037:2021

01-februar-2021

---

### Zaščitna sredstva za les - Terenska preskusna metoda za ugotavljanje relativne preventivne učinkovitosti biocidnega proizvoda za zaščito lesa izven stika z zemljo

Wood preservatives - Field test method for determining the relative protective effectiveness of a wood preservative exposed out of ground contact - Horizontal lap-joint method

Holzschutzmittel - Freilandprüfung zur Bestimmung der relativen Wirksamkeit eines Holzschutzmittels ohne Erdkontakt - Verfahren mit horizontaler Überblattung (Lap-Joint)

(standards.iteh.ai)

Produits de préservation du bois - Méthode d'essai sur le terrain pour déterminer l'efficacité protectrice relative d'un produit de préservation du bois sans contact avec le sol - Méthode avec un assemblage à joint superposé

**Ta slovenski standard je istoveten z: prEN 12037**

---

#### **ICS:**

71.100.50      Kemikalije za zaščito lesa      Wood-protecting chemicals

**oSIST prEN 12037:2021**

**en,fr,de**

**iTeh STANDARD PREVIEW**  
**(standards.iteh.ai)**

[oSIST prEN 12037:2021](#)

<https://standards.iteh.ai/catalog/standards/sist/daa3a1c3-ac76-4f19-b09b-fe80d32c0265/osist-pren-12037-2021>

EUROPEAN STANDARD  
NORME EUROPÉENNE  
EUROPÄISCHE NORM

**DRAFT**  
**prEN 12037**

December 2020

ICS 71.100.50

Will supersede CEN/TS 12037:2003

English Version

## Wood preservatives - Field test method for determining the relative protective effectiveness of a wood preservative exposed out of ground contact - Horizontal lap-joint method

Produits de préservation du bois - Méthode d'essai sur le terrain pour déterminer l'efficacité protectrice relative d'un produit de préservation du bois sans contact avec le sol - Méthode avec un assemblage à joint superposé

Holzschutzmittel - Freilandprüfung zur Bestimmung der relativen Wirksamkeit eines Holzschutzmittels ohne Erdkontakt - Verfahren mit horizontaler Überblattung (Lap-Joint)

This draft European Standard is submitted to CEN members for enquiry. It has been drawn up by the Technical Committee CEN/TC 38.

If this draft becomes a European Standard, CEN members are bound to comply with the CEN/CENELEC Internal Regulations which stipulate the conditions for giving this European Standard the status of a national standard without any alteration.

This draft European Standard was established by CEN in three official versions (English, French, German). A version in any other language made by translation under the responsibility of a CEN member into its own language and notified to the CEN-CENELEC Management Centre has the same status as the official versions.

CEN members are the national standards bodies of Austria, Belgium, Bulgaria, Croatia, Cyprus, Czech Republic, Denmark, Estonia, Finland, France, Germany, Greece, Hungary, Iceland, Ireland, Italy, Latvia, Lithuania, Luxembourg, Malta, Netherlands, Norway, Poland, Portugal, Republic of North Macedonia, Romania, Serbia, Slovakia, Slovenia, Spain, Sweden, Switzerland, Turkey and United Kingdom.

Recipients of this draft are invited to submit, with their comments, notification of any relevant patent rights of which they are aware and to provide supporting documentation.

**Warning** : This document is not a European Standard. It is distributed for review and comments. It is subject to change without notice and shall not be referred to as a European Standard.



EUROPEAN COMMITTEE FOR STANDARDIZATION  
COMITÉ EUROPÉEN DE NORMALISATION  
EUROPÄISCHES KOMITEE FÜR NORMUNG

**CEN-CENELEC Management Centre: Rue de la Science 23, B-1040 Brussels**

<b>Contents</b>	<b>Page</b>
European foreword.....	4
Introduction .....	5
1 Scope .....	6
2 Normative references .....	6
3 Terms, definitions, symbols and abbreviations.....	6
3.1 Terms and definitions .....	6
3.2 Symbols and abbreviations .....	7
4 Principle .....	7
5 Materials.....	8
5.1 Test specimens.....	8
5.1.1 Wood species .....	8
5.1.2 Wood quality.....	8
5.1.3 Provisions of test specimens.....	8
5.1.4 Dimensions and density of test specimens.....	9
5.1.5 Number of lap-joints .....	9
5.1.6 Labelling of lap-joints .....	9
5.2 End-seal compounds.....	10
6 Apparatus and equipment.....	10
7 Sample of preservation .....	12
8 Test lap-joints.....	12
8.1 Initial end sealing.....	12
8.2 Treating process.....	12
8.3 Retention of preservative .....	12
8.4 Post-treatment handling of the test lap-joints .....	13
8.4.1 Conditioning.....	13
8.4.2 Final end sealing (prior to exposure) .....	13
8.4.3 Labelling.....	13
8.4.4 Assembling lap-joints .....	13
9 Untreated control lap-joints.....	13
10 Exposure test site .....	13
10.1 Selection of test site.....	13
10.2 Installation of the lap-joints a the test site .....	13
11 Inspection .....	13
12 Assessment.....	14
13 Duration of the test.....	15
14 Validity of test.....	15
15 Test report.....	15
Annex A (informative) Information on an additional test with a reference preservative and on treatment processes .....	17
A.1 Additional test with a reference preservative.....	17
A.1.1 General.....	17

A.1.2	Reference preservative .....	17
A.1.3	Additional reference preservative 1.....	17
A.1.4	Additional reference preservative 2.....	17
A.1.5	Tolerances of variation.....	18
A.1.6	Reference lap-joint.....	18
A.1.6.1	General .....	18
A.1.6.2	Initial end sealing .....	18
A.1.6.3	Treating process .....	18
A.1.6.4	Retention of reference preservative.....	19
A.1.6.5	Post-treatment handling of the reference lap joints.....	19
A.1.6.6	Exposure .....	19
A.1.6.7	Inspections.....	19
A.1.6.8	Assessment and duration of test.....	19
A.2	Model treatments methods .....	19
A.2.1	General .....	19
A.2.2	Brushing.....	19
A.2.3	Spraying in a spray tunnel.....	19
A.2.4	Dip process.....	19
A.2.5	Steeping.....	19
A.2.6	Double vacuum process.....	20
A.2.7	Full-cell process .....	20
Annex B (informative)	Example of a test report.....	21
Annex C (informative)	Determination of the preventive efficacy of a test preservative or components of a test preservative against staining fungi using horizontal lap-joint method.....	27
C.1	General .....	27
C.2	Definitions.....	27
C.3	Assessment.....	27
Annex D (informative)	Test field site .....	29
Bibliography	.....	30

ITeH STANDARD PREVIEW  
(standards.iteh.ai)

oSIST prEN 12037:2021

<https://standards.iteh.ai/catalog/standards/sist/daa3a1c3-ac76-4f19-b09b-fe80d32c0265/osist-pren-12037-2021>

## prEN 12037:2020 (E)

### European foreword

This document (prEN 12037:2020) has been prepared by Technical Committee CEN/TC 38 “Durability of wood and wood-based products”, the secretariat of which is held by AFNOR.

This document is currently submitted to the CEN Enquiry.

This document will supersede CEN/TS 12037:2003.

In relation to CEN/TS 12037:2003, the following main modifications have been made:

- change of variation in density of test specimens;
- change of grading system for evaluation.

## iTeh STANDARD PREVIEW (standards.iteh.ai)

[oSIST prEN 12037:2021](https://standards.iteh.ai/catalog/standards/sist/daa3a1c3-ac76-4f19-b09b-fe80d32c0265/osist-pren-12037-2021)

<https://standards.iteh.ai/catalog/standards/sist/daa3a1c3-ac76-4f19-b09b-fe80d32c0265/osist-pren-12037-2021>

## Introduction

The main objective of the method is to evaluate the relative effectiveness of the preservative, applied to jointed specimens of Scots pine sapwood by a treatment method relevant to its intended practical use and as such does not necessarily accelerate decay but reflects probable performance in service.

The method is concerned with the protection against decay after exposure to a wide range of microorganisms occurring out of ground contact under natural conditions. It takes into account also physico-chemical effects of weathering on the performance of the preservative treated wood.

Since the lap-joints are exposed to natural outdoor conditions during the test period, variations in test conditions from one exposure site to another should be expected. Differences in climate, especially rainfall, will inevitably influence the general rate of development of decay fungi. However, by comparing the results obtained for the test preservative with those obtained for untreated control lap-joints, the relative protective effectiveness of the preservative under test can be evaluated.

The procedures described in this document are intended to be carried out by suitably trained and/or supervised specialists. Appropriate safety precautions should be observed throughout the use of the document.

## iTeh STANDARD PREVIEW (standards.iteh.ai)

[oSIST prEN 12037:2021](https://standards.iteh.ai/catalog/standards/sist/daa3a1c3-ac76-4f19-b09b-fe80d32c0265/osist-pren-12037-2021)

<https://standards.iteh.ai/catalog/standards/sist/daa3a1c3-ac76-4f19-b09b-fe80d32c0265/osist-pren-12037-2021>

**prEN 12037:2020 (E)****1 Scope**

This document describes a method of test for wood preservatives that are intended for use in wood to be exposed to the weather out of contact with the ground without the additional protection of a surface coating.

The method is applicable to the testing of commercial or experimental preservatives applied by techniques appropriate to commercial practice. The method is applicable to chemical products used individually or in combination to prevent the development of decay and/or – optional – the development of disfiguring organisms in wood and, where suitable, in wood-based products.

NOTE 1 The method can also be used to test other treated wood species and naturally durable timbers. It can be adapted for testing the field performance of other wood based systems and treatments designed to enhance durability, for example treated or untreated wood based composites, timber treated with non-biocidal systems, chemically modified or heat treated timber.

NOTE 2 Although the test is used to assess decay, it is possible to use the method to additionally assess stain or each separately when relevant.

**2 Normative references**

The following documents are referred to in the text in such a way that some or all of their content constitutes requirements of this document. For dated references, only the edition cited applies. For undated references, the latest edition of the referenced document (including any amendments) applies.

EN 212, *Wood preservatives – General guidance on sampling and preparation for analysis of wood preservatives and treated timber*

**3 Terms, definitions, symbols and abbreviations**

For the purposes of this document, the following definitions, symbols and abbreviations apply.

ISO and IEC maintain terminological databases for use in standardization at the following addresses:

- IEC Electropedia: available at <http://www.electropedia.org/>
- ISO Online browsing platform: available at <https://www.iso.org/obp>

**3.1 Terms and definitions****3.1.1****active ingredient**

individual chemical compound or compounds included in the wood preservative product to give it specific activity against the particular biological agencies of deterioration

**3.1.2****penetrating treatment process**

process which includes features or procedures intended to overcome the natural resistance of wood to penetration by a wood preservative product in its ready for use form

Note 1 to entry: Such processes include for example currently practised technologies of diffusion treatments, double-vacuum and vacuum-pressure methods.



**3.1.3****superficial application process**

process which does not include particular features or procedures intended to overcome the natural resistance of wood to penetration by a wood preservative product in its ready for use form

Note 1 to entry: Such processes include for example brush and spray techniques and short-term immersion (dipping) processes in which wood normally has only a few minutes contact time with the preservative.

**3.1.4****supplier**

sponsor of the test

**3.1.5****target retention**

retention recommended by the supplier

**3.1.6****application rate**

amount of preservative product per square metre to be applied in superficial processes recommended by the supplier

**3.2 Symbols and abbreviations****3.2.1** **$\nu$ nUD**

nominal median rating for the upper side of the lap-joints for sets of replicates at the assessment of the extent of decay

**iTeh STANDARD PREVIEW**  
(standards.iteh.ai)

[oSIST prEN 12037:2021](https://standards.iteh.ai/catalog/standards/sist/daa3a1c3-ac76-4f19-b09b-fe80d32c0265/osist-pren-12037-2021)

**3.2.2** **$\nu$ nLD**

nominal median rating for the lower side of the lap-joints for sets of replicates at the assessment of the extent of decay

<https://standards.iteh.ai/catalog/standards/sist/daa3a1c3-ac76-4f19-b09b-fe80d32c0265/osist-pren-12037-2021>

**3.2.3** **$\nu$ nJD**

nominal median rating for surfaces within the joint areas of the lap-joints for sets of replicates at the assessment of the extent of decay

Note 1 to entry: For symbols for the optional assessment of attack by staining fungi see Annex C.

**4 Principle**

Jointed specimens (lap-joints) consisting of two overlapping parts (joint members) held together mechanically are placed horizontally, out of contact with the ground and exposed to the weather. The lap-joints are dismantled and examined at intervals. The extent of microbiological attack on the external surfaces and within the joint areas is rated according to a specified rating system. Data for lap-joints treated with the test product are compared with those generated from untreated specimens to assess relative effectiveness.

**prEN 12037:2020 (E)****5 Materials****5.1 Test specimens****5.1.1 Wood species**

Susceptible wood species that can be completely penetrated with preservative shall be chosen as follows:

- for every test the sapwood of Scots pine (*Pinus Sylvestris* L) shall be used;
- if desired other wood species or wood-based materials may be incorporated in the test;
- should be changed for modified wood.

**5.1.2 Wood quality**

The wood shall be straight-grained and free from visible cracks, stain, decay, insect damage and other defects. Some knots are permitted as defined in 5.1.3. The wood shall not have been water-stored, floated, chemically treated, steamed or dried at temperatures above 60 °C. The wood shall originate from trees preferably felled in winter.

The Scots pine shall be exclusively sapwood containing little resin and having between 2,5 and 10 annual rings per 10 mm. The proportion of latewood in the annual rings shall not exceed 30 % of the whole. Use wood without reaction wood or juvenile wood.

If other wood species are to be used the range in the number of annual rings per 10 mm for each wood species shall be mentioned in the report.

**5.1.3 Provisions of test specimens**

The longitudinal faces shall be parallel to the direction of the grain. The annual rings shall have a contact angle of not greater than 10 °C to the broad faces of the test specimens. Make transverse cuts, neatly to give sharp edges and a fine-sawn finish to the end-grain surfaces.

All the wood used in the test shall have been handled and dried in the same way.

Wood from at least three trees shall be used and evenly distributed among the different groups of lap-joints.

Condition in a conditioning chamber (see 6.2) the timber stock to  $(12 \pm 2$  for Scots pine) % (*m/m*) moisture content. Prepare lengths of timber with  $(38 \pm 1)$  mm  $\times$   $(85 \pm 1)$  mm cross section by sawing (see 6.1) and planning (see Figure 1).

For other wood species condition to constant moisture content.

NOTE 1 A moisture meter of the two-pronged electrical conductivity type is suitable for assessing moisture content.

Each lap-joint shall be prepared from a single piece of wood as two members  $(180 \pm 1)$  mm long and separated by no more than 100 mm, to allow for removal of knots and associated grain aberration, to ensure a tight fit during the test (see Figure 1). Within the overlapping part and the adjacent 50 mm there shall be no knots and in the rest of each member there are no more than 3 sound knots, the diameter of which shall not exceed 10 mm.

Machine the joint in a way that after assembly of the two members the pith faces are on the same side of the assembled joint (see Figure 1).

Store the joint members in the conditioning chamber (6.2) until required for treating.

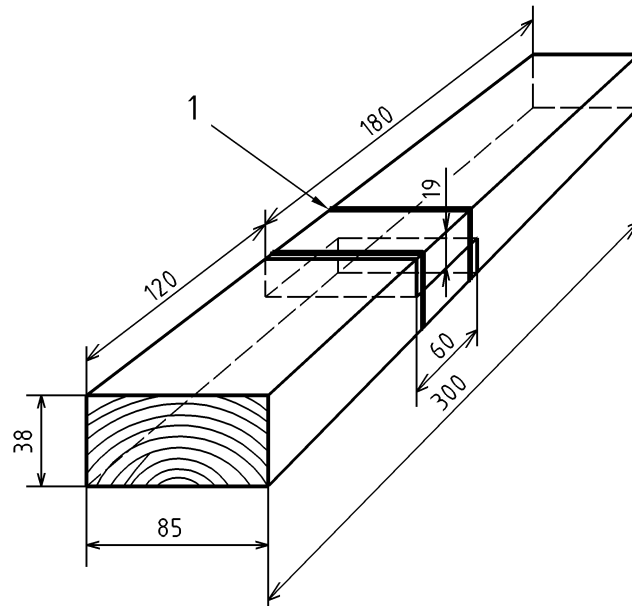
**Key**

1 Cable strap

**Figure 1 — Lap-joint**

iTeh STANDARD PREVIEW  
(standards.iteh.ai)

NOTE 2 The lap-joint members can be held together by two cable straps (6.7). The lap-joint is shown without the weatherproof end seal.

**5.1.4 Dimensions and density of test specimens**

<https://standards.iteh.ai/catalog/standards/sist/daa3a1c3-ac76-4f19-b09b-58612-023058/m/12037-2021>

The dimensions of each lap-joint at  $(12 \pm 2) \% (m/m)$  moisture content shall be  $(300 \pm 2) \text{ mm} \times (85 \pm 1) \text{ mm} \times (38 \pm 1) \text{ mm}$  with an overlapping close fitting part at mid-length of  $(60 \pm 1) \text{ mm}$  (see Figure 1).

In a batch of specimens to be treated, the density of an individual is permitted to differ from the mean value of the batch by  $\pm 15 \%$ . This tolerance is increased to  $\pm 20 \%$  for the untreated specimens. The mean density of the treated specimens used for the test shall be recorded in the test report.

**5.1.5 Number of lap-joints**

Prepare at least 10 lap-joints for each combination of test parameters [wood species (see 5.1.1), test preservative (see Clause 7), retention level or application rate (see 8.3), and untreated control (see Clause 10)].

It is normally necessary to treat a higher number of lap-joints so that the required number can be selected after treatment (see 8.2) and the inclusion of “abnormal” joints avoided. Optionally extra lap-joints may be prepared for chemical analyses during exposure.

**5.1.6 Labelling of lap-joints**

Individual members of each lap-joint shall be assigned unique identification numbers in such a way that these numbers are retained through all preparation operations. After preservative treatment an identification label or tag of long-lasting material shall be affixed e.g to the side of each lap-joint away from the joint area. The labels shall be of a material which is inert to the wood and the chemicals it contains after treatment and conditioning.

## prEN 12037:2020 (E)

### 5.2 End-seal compounds

**5.2.1 Preservative resistant end-seal:** a material resistant to the penetration of the test preservative solutions.

Polyvinyl acetate (PVAc) glues have been found to be suitable for many organic solvent formulations. For water-borne formulations the weatherproof end-seal (5.2.2) may be used.

**5.2.2 Weatherproof end-seal:** a material which prevents water entry as well as microbial infection and remains effective during long term exposure to the weather.

NOTE Two coats of an epoxy-resin/pitch compound have been found to be suitable.

## 6 Apparatus and equipment

**6.1 Wood working equipment,** including a saw capable of producing a fine sawn finish.

**6.2 Conditioning chamber,** well ventilated and controlled at  $(20 \pm 2)$  °C and  $(65 \pm 5)$  % relative humidity.

**6.3 Equipment,** suitable for carrying out the treatment specified by the supplier.

**6.4 Balance,** capable of weighing to the nearest 0,1 g.

**6.5 Safety equipment and protective clothing,** appropriate for the test product, to ensure the safety of the operator.

**6.6 Labels and fixing pins,** both long-lasting, inert and corrosion resistant with similar fixing pins.

**6.7 Fixing material,** cable straps, inert and weather resistant to be used for fixing the two members of each joint together.

NOTE A suitable material of the straps is clear or white polyamide with a dimension of ca 360 mm × 5 mm. These straps can easily be removed at the inspections and replaced by new straps when joints are returned to the exposure racks.

Alternatively custom designed stainless steel metal clips may be used. A suitable clip design is shown in Figure 2.

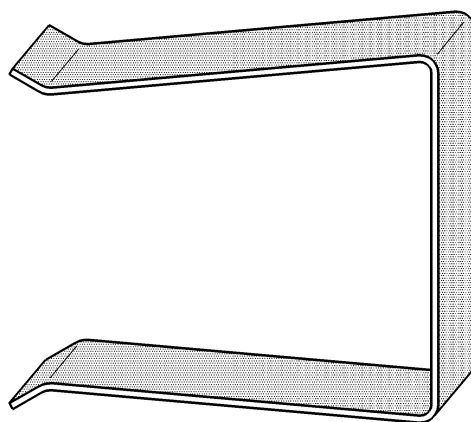

**Figure 2 — Suitable clip fabricated out of stainless steel to hold lap-joint in place**

Two clips may be needed per test assembly.