



Designation: ~~E948-05a~~ Designation: E 948 – 09

Standard Test Method for Electrical Performance of Photovoltaic Cells Using Reference Cells Under Simulated Sunlight¹

This standard is issued under the fixed designation E 948; the number immediately following the designation indicates the year of original adoption or, in the case of revision, the year of last revision. A number in parentheses indicates the year of last reapproval. A superscript epsilon (ϵ) indicates an editorial change since the last revision or reapproval.

1. Scope

1.1 This test method covers the determination of the electrical performance of a photovoltaic cell under simulated sunlight by means of a calibrated reference cell procedure.

1.2 Electrical performance measurements are reported with respect to a select set of standard reporting conditions (SRC) (see Table 1) or to user-specified conditions.

1.2.1 The SRC or user-specified conditions include the cell temperature, the total irradiance, and the reference spectral irradiance distribution.

1.3 This test method is applicable only to photovoltaic cells with a linear response over the range of interest.

1.4 The cell parameters determined by this test method apply only at the time of test, and imply no past or future performance level.

1.5

1.5 The values stated in SI units are to be regarded as standard. No other units of measurement are included in this standard.

1.6 *This standard does not purport to address all of the safety concerns, if any, associated with its use. It is the responsibility of the user of this standard to establish appropriate safety and health practices and determine the applicability of regulatory limitations prior to use.*

2. Referenced Documents

2.1 *ASTM Standards:*²

E 490 [Standard Solar Constant and Zero Air Mass Solar Spectral Irradiance Tables](#)

E 491 [Practice for Solar Simulation for Thermal Balance Testing of Spacecraft](#)

E 691 [Practice for Conducting an Interlaboratory Study to Determine the Precision of a Test Method](#)

E 772 [Terminology Relating to Solar Energy Conversion](#)

E 927 [Specification for Solar Simulation for Terrestrial Photovoltaic Testing](#)

E 973 [Test Method for Determination of the Spectral Mismatch Parameter Between a Photovoltaic Device and a Photovoltaic Reference Cell](#)

~~E1039 Test Method for Calibration of Silicon Non-Concentrator Photovoltaic Primary Reference Cells Under Global Irradiation~~

E 1125 [Test Method for Calibration of Primary Non-Concentrator Terrestrial Photovoltaic Reference Cells Using a Tabular Spectrum](#)

E 1328 [Terminology Relating to Photovoltaic Solar Energy Conversion](#)

E 1362 [Test Method for Calibration of Non-Concentrator Photovoltaic Secondary Reference Cells](#)

G 173 [Tables for Reference Solar Spectral Irradiances: Direct Normal and Hemispherical on 37°³⁷ Tilted Surface](#)

3. Terminology

3.1 *Definitions*—Definitions of terms in this test method may be found in Terminology E 772 and Terminology E 1328.

3.2 *Definitions of Terms Specific to This Standard:*

3.2.1 *cell temperature, °C, n*—the temperature of the semiconductor junction of a photovoltaic cell.

3.2.2 *junction temperature, n*—synonym for *cell temperature*.

3.2.3 *light source, n*—a source of radiant energy used for cell performance measurements that simulates natural sunlight.

3.3 ~~*Symbols:*~~ ~~*Symbols:*~~ *Symbols:*

¹ This test method is under the jurisdiction of ASTM Committee E44 on Solar, Geothermal, and Other Alternative Energy Sources and is the direct responsibility of Subcommittee E44.09 on Photovoltaic Electric Power Conversion.

Current edition approved Sept. April 1, 2005-2009. Published October 2005-May 2009. Originally approved in 1993. Last previous edition approved in 2005 as E 948 – 05a.

² For referenced ASTM standards, visit the ASTM website, www.astm.org, or contact ASTM Customer Service at service@astm.org. For *Annual Book of ASTM Standards* volume information, refer to the standard's Document Summary page on the ASTM website.

TABLE 1 Standard Reporting Conditions

Reference Spectral Irradiance Distribution	Total Irradiance (Wm ⁻²)	Temperature (°C)
Tables G 173 Direct Normal	1000	25
Tables G 173 Hemispherical	1000	25
Tables E 490	1366.1	25

3.3.1 The following symbols and units are used in this test method:

A —cell area, m²

α_r —temperature coefficient of reference cell, °C⁻¹

C —calibration constant of reference cell, Am²W⁻¹

E —irradiance, Wm⁻²

E_o —standard reporting irradiance, Wm⁻²

η —efficiency, %

FF

η —efficiency, %

FF —fill factor, %

I —current, A

I_o —current with respect to SRC, A

I_r —reference cell short-circuit current, A

I_{sc} —short-circuit current, A

M —spectral mismatch parameter

P_m —maximum power, W

R_s —series resistance, Ω

T —temperature, °C

T_o —standard reporting temperature, °C

T_r —temperature of reference cell, °C

V —voltage, V

V_o —voltage with respect to SRC, V

V_{oc} —open-circuit voltage, V

4. Summary of Test Method

4.1 The performance test of a photovoltaic cell consists of measuring the electrical current versus voltage (I-V) characteristic of the cell while illuminated by a suitable light source.

4.2 A calibrated photovoltaic reference cell (see 6.1) is used to determine the total irradiance during the test and to account for the spectral distribution of the light source.

4.3 Simulated sunlight is used as the light source for the electrical performance measurement, and solar simulation requirements are defined in Specification E 927(terrestrial applications) and Practice E 491 (space applications).

4.4 The data from the measurements are corrected to standard reporting conditions, or to optional user-specified reporting conditions. The standard reporting conditions are defined in Table 1.³

4.4.1 Measurement error caused by deviations of the irradiance conditions from the SRC is corrected using the total irradiance measured with the reference cell and the spectral mismatch parameter, M , which is determined in accordance with Test Method E 973.

4.4.2 Measurement error caused by deviation of the cell temperature from the SRC is minimized by maintaining the cell temperature close to the required value (see 7.6.1).

5. Significance and Use

5.1 It is the intent of this test method to provide a recognized method for testing and reporting the electrical performance of photovoltaic cells.

5.2 The test results may be used for comparison of cells among a group of similar cells or to compare diverse designs, such as different manufacturers' products. Repeated measurements of the same cell may be used to study changes in device performance.

5.3 This test method determines the electrical performance of a cell based upon the output power at a single instant of time. It does not provide for integrating the output power over a given period of time and conditions to predict an energy output.

5.4 This test method requires a reference cell calibrated with respect to an appropriate reference spectral irradiance distribution, such as Tables E 490, or G 173. It is the responsibility of the user to determine which reference spectral irradiance distribution is appropriate for a particular application.

³ Wehrli, C., Extraterrestrial Solar Spectrum, Publ. No. 615, Physikalisch-Meteorologisches Observatorium and World Radiation Center, Davos Switzerland, 1985.

6. Apparatus

6.1 *Photovoltaic Reference Cell* —A calibrated reference cell is used to determine the total irradiance during the electrical performance measurement.

6.1.1 Reference cells may be calibrated in accordance with Test Methods E1039, E1125, E 1125 or E 1362, as is appropriate for a particular application.

NOTE 1—No reference cell calibration standards presently exist for space applications, although procedures such as high-altitude balloon and low-earth orbit flights are being used to calibrate such reference cells.

6.1.2 A current measurement instrument (see 6.3) shall be used to determine the I_{sc} of the reference cell under the light source.

6.2 *Test Fixture*— Both the cell to be tested and the reference cell are mounted in a fixture that meets the following requirements.

6.2.1 The test fixture shall ensure a uniform lateral temperature distribution to within $\pm 0.5^{\circ}\text{C}$ during the performance measurement.

6.2.2 The test fixture shall include a provision for maintaining a constant cell temperature for both the reference cell and the cell to be tested (see 7.6.1).

NOTE 2—When using pulsed or shuttered light sources, it is possible that the cell temperature will increase upon initial illumination, even when the cell temperature is controlled.

6.2.3 The test fixture, when placed in the simulated sunlight, shall ensure that the field-of-view of both the reference cell and the cell to be tested are identical.

NOTE 3—Some solar simulators may have significant amounts of irradiation from oblique or non-perpendicular angles to the test plane. In these cases, it is important that the cell to be tested and the reference cell have similar reflectance and cosine-response characteristics.

6.2.4 A four-terminal connection (also known as a Kelvin connection, see Fig. 1) from the cell to be tested to the I-V measurement instrumentation (see 6.3-6.5) shall be used.

6.3 *Current Measurement Equipment*— The instrument or instruments used to measure the cell current and the I_{sc} of the reference cell shall have a resolution of at least 0.02 % of the maximum current encountered, and shall have a total error of less than 0.1 % of the maximum current encountered.

6.4 *Voltage Measurement Equipment* —The instrument or instruments used to measure the cell voltage shall have a resolution of at least 0.02 % of the maximum voltage encountered, and shall have a total error of less than 0.1 % of the maximum voltage encountered.

6.5 *Variable Load*— An electronic load, such as a variable resistor or a programmable power supply, used to operate the cell to be tested at different points along its I-V characteristic.

6.5.1 The variable load shall be capable of operating the cell to be tested at an I-V point where the voltage is within 1 % of V_{oc} in the power-producing quadrant.

6.5.2 The variable load shall be capable of operating the cell to be tested at an I-V point where the current is within 1 % of I_{sc} in the power-producing quadrant.

6.5.3 The variable load must allow an output power (the product of cell current and cell voltage) resolution of at least 0.2 % of the maximum power.

6.5.4 The electrical response time of the variable load must be fast enough to sweep the range of I-V operating points during the measurement period.

NOTE 4—It is possible that the response time of cell to be tested may limit how fast the range of I-V operating points can be swept, especially when

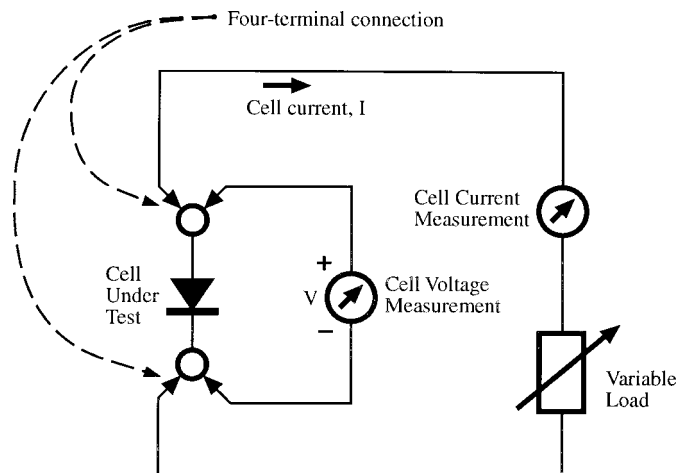

FIG. 1 I-V Measurement Schematic