



Designation: ~~F2085-08a~~ Designation: F 2085 – 09

## Standard Consumer Safety Specification for Portable Bed Rails<sup>1</sup>

This standard is issued under the fixed designation F 2085; the number immediately following the designation indicates the year of original adoption or, in the case of revision, the year of last revision. A number in parentheses indicates the year of last reapproval. A superscript epsilon ( $\epsilon$ ) indicates an editorial change since the last revision or reapproval.

### INTRODUCTION

This consumer safety specification addresses portable bed rail incidents that were identified by the U.S. Consumer Product Safety Commission (CPSC).

In response to incident data supplied by the CPSC, this consumer safety specification attempts to minimize the following type of potential hazard through labeling and performance requirements: entrapment between the portable bed rail and mattress in the bed rail structure and entanglement on protrusions. Entrapment of a child by the head or neck can result in asphyxiation.

This consumer safety specification is written within the current state-of-the-art of portable bed rail technology. It is intended that this specification will be updated whenever substantive information becomes available that necessitates additional requirements or justifies the revision of existing requirements.

This consumer safety specification is not intended to ~~cover~~ address all the hazards of bed rails that are either blatantly misused or used in a careless manner that disregards the ~~safety instructions in the instructional literature and~~ warning statements provided with each bed rail.

### 1. Scope

1.1 This consumer safety specification establishes requirements for the performance of portable bed rails. It also contains requirements for labeling and instructional literature.

1.2 This consumer safety specification is intended to minimize hazards to children resulting from normal use and reasonably foreseeable misuse of portable bed rails.

1.3 For the purpose of this consumer safety specification, a portable bed rail is a device intended to be installed on an adult bed to prevent children from falling out of bed. These bed rails are intended for children who can get in and out of an adult bed unassisted (typically from 2 to 5 years of age).

1.4 No bed rail as defined in 3.1.1 that is produced after the approval date of this consumer safety specification shall, either by label or other means, indicate compliance with this specification unless it conforms to all the requirements contained herein.

1.5 The values stated in inch-pound units are to be regarded as standard. The values given in parentheses are mathematical conversions to SI units that are provided for information only and are not considered standard.

1.6 The following precautionary caveat pertains only to the test methods portion in Section 8 of this specification. *This standard does not purport to address all of the safety concerns, if any, associated with its use. It is the responsibility of the user of this standard to establish appropriate safety and health practices and determine the applicability of regulatory requirements prior to use.*

### 2. Referenced Documents

#### 2.1 ASTM Standards:<sup>2</sup>

D 3359 [Test Methods for Measuring Adhesion by Tape Test](#)

D 3574 [Test Methods for Flexible Cellular Materials Slab, Bonded, and Molded Urethane Foams](#)

#### 2.2 Federal Standards:<sup>3</sup>

16 CFR Part 1303 Ban of Lead-Containing Paint and Certain Consumer Products Bearing Lead-Containing Paint

16 CFR Part 1500 Federal Hazardous Substances Act Regulations, including Sections:

<sup>1</sup> This consumer safety specification is under the jurisdiction of ASTM Committee F15 on Consumer Products and is the direct responsibility of Subcommittee F15.11 on Bed Rails.

Current edition approved ~~Dec: April 1, 2008; 2009~~. Published ~~February~~ May 2009. Originally approved in 2001. Last previous edition approved in 2008 as F 2085 – 08a.

<sup>2</sup> For referenced ASTM standards, visit the ASTM website, [www.astm.org](http://www.astm.org), or contact ASTM Customer Service at [service@astm.org](mailto:service@astm.org). For *Annual Book of ASTM Standards* volume information, refer to the standard's Document Summary page on the ASTM website.

<sup>3</sup> Available from U.S. Government Printing Office Superintendent of Documents, 732 N. Capitol St., NW, Mail Stop: SDE, Washington, DC 20401.

- 16 CFR 1500.48 Technical Requirements for Determining a Sharp Point in Toys and Other Articles Intended for Use by Children Under 8 Years of Age
- 16 CFR 1500.49 Technical Requirements for Determining a Sharp Metal or Glass Edge in Toys and Other Articles Intended for Use by Children Under 8 Years of Age
- 16 CFR Part 1501 Method for Identifying Toys and Other Articles Intended for Use by Children Under 3 Years of Age which Present Choking, Aspiration, or Ingestion Hazards Because of Small Parts

### 3. Terminology

#### 3.1 Definitions of Terms Specific to This Standard:

- 3.1.1 *adjacent type bed rail, n*—portable bed rail in which the guard portion (portion that a child would contact when rolling toward the mattress edge) of the unit is essentially a vertical plane that is pushed against the side of the mattress. The guard remains immediately next to the mattress and does not extend over the mattress surface.
- 3.1.2 *arm, n*—for the purpose of this specification, a device(s) attached to a bed rail that extends between the mattress and mattress foundation and is intended to secure the bed rail to the bed.
- 3.1.3 *bed manufacturer specific type portable bed rail, n*—portable bed rail that is intended for use on a certain type or model(s) of bed as specified by the manufacturer of the bed or bed rail, or both.
- 3.1.4 *conspicuous, adj*—label that is visible, when the portable bed rail is in the manufacturer’s recommended use position, to a person standing near the unit at any one position around the unit but not necessarily visible from all positions.
- 3.1.5 *mattress-top bed rail, n*—portable bed rail in which the guard portion (portion that a child would contact when rolling toward the mattress edge) extends over the sleeping surface of the mattress.
- 3.1.6 *nonpaper label, adj*—any label made of fabric or other material (such as plastic or metal) which either will not tear without the aid of tools, or tears leaving a sharply defined edge.
- 3.1.7 *paper label, adj*—any label material (except fabric) which tears without the aid of tools and leaves a fibrous edge.
- 3.1.8 *permanent, adj*—marking or label shall be considered permanent if, during an attempt to manually remove it without the aid of tools or solvents, it cannot be removed, or it tears upon removal, or such action damages the surface to which it is attached.
- 3.1.9 *portable bed rail, n*—portable railing installed on the side of an adult bed and/or on the mattress surface which is intended to keep a child from falling out of bed.
- 3.1.9.1 *Discussion*—Portable bed rails include those made for a specific manufacturer’s bed.

### 4. Calibration and Standardization

- 4.1 The product shall be completely assembled, unless otherwise noted, in accordance with the manufacturer’s instructions.
- 4.2 No testing shall be conducted within 48 h of manufacturing.
- 4.3 The product to be tested shall be in a room with an ambient temperature of  $73 \pm 9^\circ\text{F}$  ( $23 \pm 5^\circ\text{C}$ ) for at least 1 h prior to testing. Testing shall then be conducted within this temperature range.
- 4.4 All testing required by this specification shall be conducted on the same unit.

### 5. General Requirements

- 5.1 There shall be no hazardous sharp points or edges as defined by 16 CFR 1500.48 and 16 CFR 1500.49.
- 5.2 There shall be no small parts as defined by 16 CFR 1501.
- 5.3 Any exposed wood parts shall be smooth and free from splinters.
- 5.4 The bed rail shall conform to 16 CFR 1303.
- 5.5 Warning labels (whether paper or nonpaper) shall be permanent when tested per 7.1-7.3. Warning statements applied directly onto the surface of the product by hot stamping, heat transfer, printing, wood burning, etc. shall be permanent when tested per 6.4. Nonpaper labels shall not liberate small parts when tested in accordance with 7.5.

### 6. Performance Requirements

- 6.1 *Structural Integrity*—All tests of 8.1 shall be performed sequentially. After testing in accordance with 8.1, there shall be no hazardous condition created as defined in Section 5.
- 6.2 *Openings*—Holes or slots that extend entirely through a wall section of any rigid material less than 0.375-in. (9.53-mm) thick and admit a 0.210-in. (5.33-mm) diameter rod shall also admit a 0.375-in. (9.53-mm) diameter rod. Holes or slots that are between 0.210-in. (5.33-mm) and 0.375-in. (9.53-mm) and have a wall thickness less than 0.375-in. (9.53-mm) but are limited in depth to 0.375-in. (9.53-mm) maximum by another rigid surface shall be permissible (see Fig. 1). The product shall be evaluated in all manufacturer’s recommended use positions.
- 6.3 *Enclosed Openings*—When tested in accordance with 8.2, there shall be no enclosed openings in the enclosed structure of the portable bed rail that will permit passage of the Torso Probe shown in Fig. 2.
- 6.4 *Openings Created by Bed Rail Displacement of Adjacent Style Portable Bed Rails*—When tested in accordance with the procedure in 8.3, there shall be no opening between the mattress and the bed rail that will permit passage of the Torso Probe shown in Fig. 2. Passage is defined as the entire Torso Probe passing the horizontal plane that extends from the top surface of the mattress toward the guard portion of the bed rail.

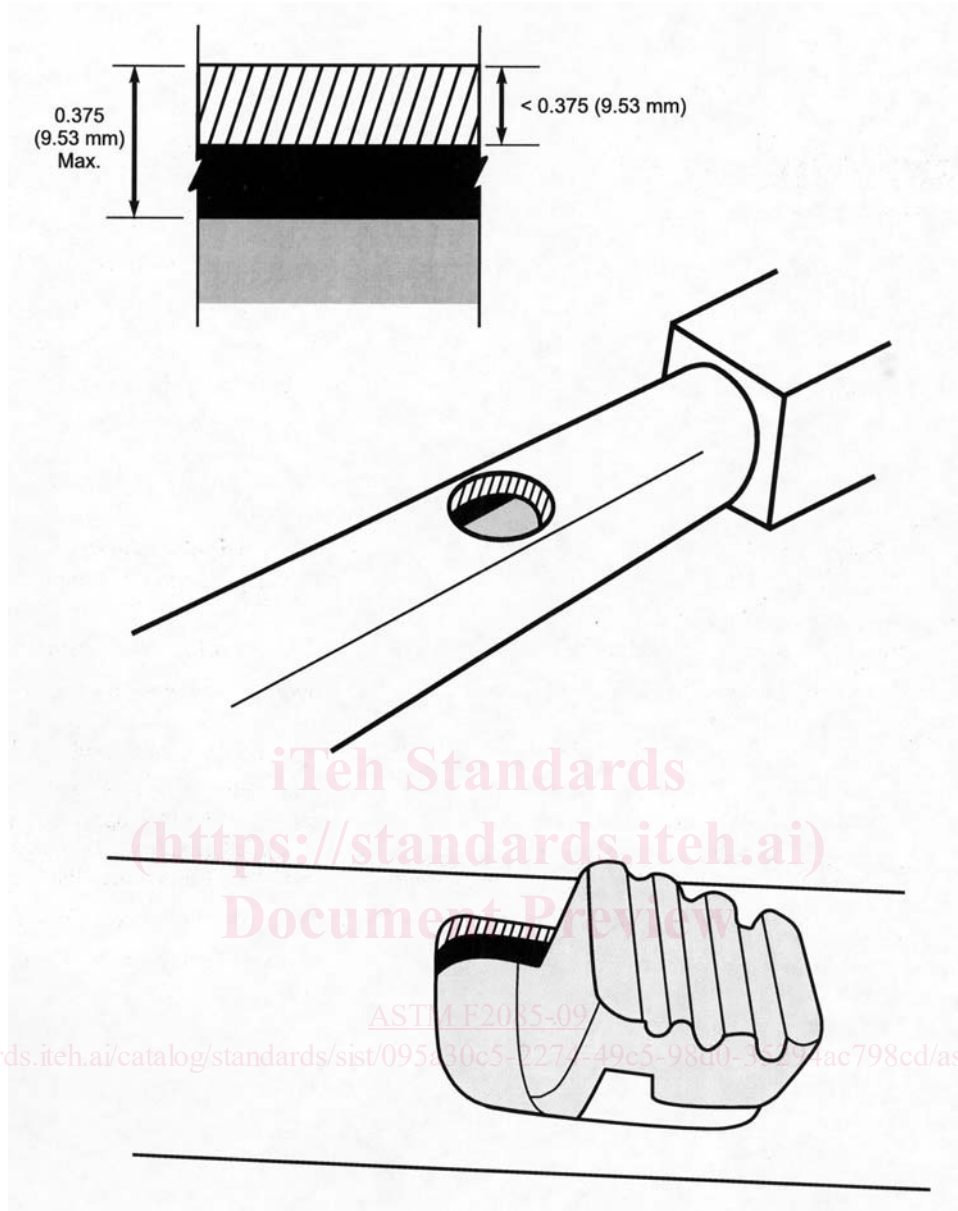

FIG. 1 Opening Example

6.4.1 Bed rails that are marketed as being usable on a bed that has a mattress support that is solid rather than a box spring shall be tested on Platform 3, as defined in 7.1.3, in accordance with 8.3.

6.5 *Openings Created by Displacement of Mattress-Top Portable Bed Rails*—When tested in accordance with the procedure in 8.4, the Wedge Probe (Fig. 3) shall not penetrate to a depth greater than 4.5 in. (114 mm) and the bed rail shall not displace horizontally such that the inner edge of the bed rail moves off the top mattress surface. The inner edge of the bed rail is the edge where the Wedge Probe is inserted.

6.5.1 Bed rails that are marketed as being usable on a bed that has a mattress support that is solid rather than a box spring shall be tested on Platform 3, as defined in 7.1.3, in accordance with 8.3.

6.6 *Openings Created by Displacement of Portable Bed Rails Intended for Use on Specific Manufacturers' Beds*— When tested in accordance with the procedure in 8.5 there shall be no opening between the mattress and bed rail that will permit passage of the Torso Probe (Fig. 2). Passage is defined as the entire Torso Probe passing the horizontal plane toward the guard position of the bed rail.

6.7 *Protrusions*—Neither string on the weight gauge shall stay attached to a protrusion when tested in accordance with the procedure in 8.6.

6.8 *Openings Between Bedposts (Headboard, Footboards, Etc.) and Ends of Portable Bed Rail*—When installed in accordance with the manufacturer's instructions on Test Platforms 1 and 2 there shall be a minimum of 9 in. (230 mm) between the left and right ends of the portable bed rail and the corresponding left and right ends of the test mattress.

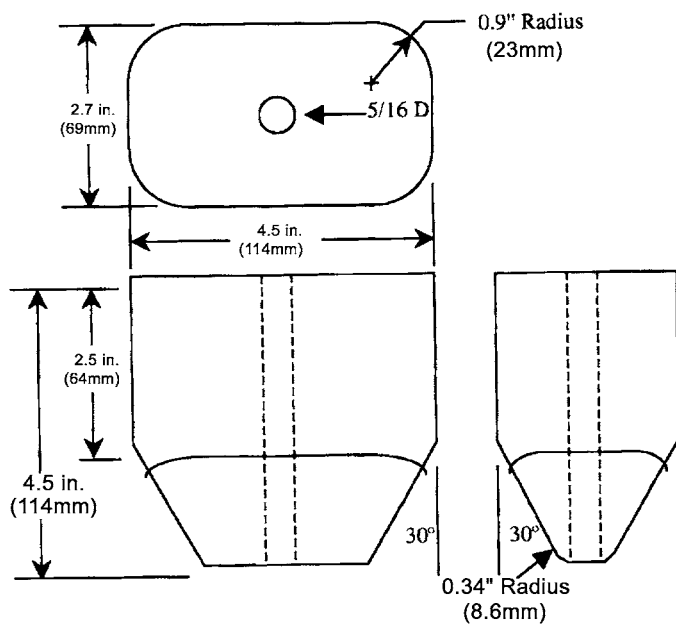

Block shall be fabricated from hardwood and have a smooth finish. Webbing material (not shown) to be threaded through center hole and firmly anchored at the back end of the probe.

FIG. 2 Torso Probe

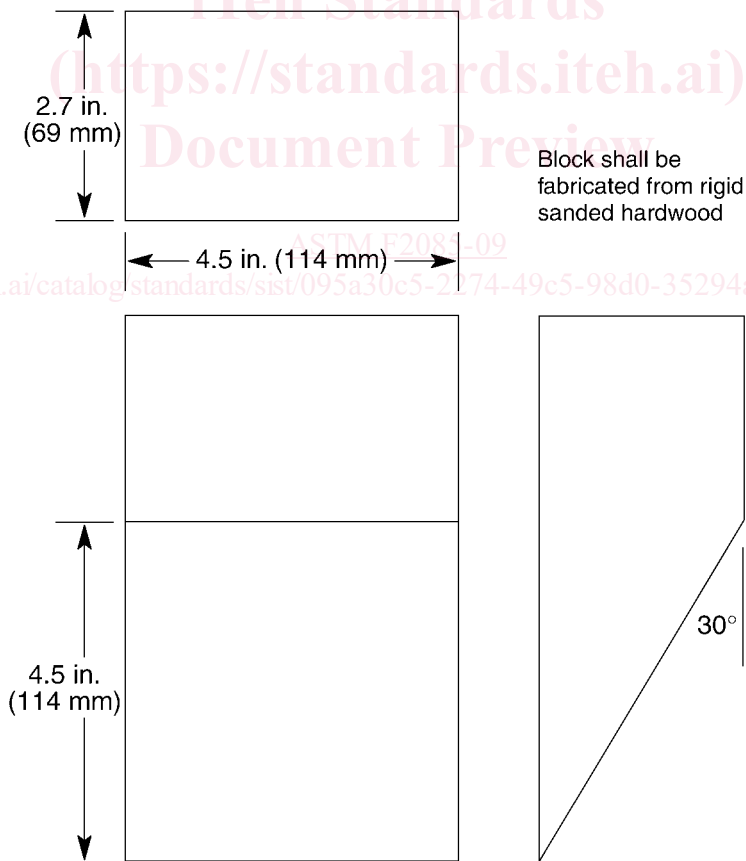

Block shall be fabricated from rigid sanded hardwood

FIG. 3 Wedge Probe

6.8.1 *Adjacent Style and Mattress Top Portable Bed Rails*—When installed in accordance with the manufacturer’s instructions on Test Platforms 1 and 2 there shall be a minimum of 9 in. (230 mm) between the left and right ends of the portable bed rail and the corresponding left and right ends of the test mattress.

6.8.2 *Bed Manufacturer Specific Type Portable Bed Rails* —When installed on the bed manufacturer’s bed with the mattress from platforms 1 and 2, there shall be a minimum of 9 in. (230 mm) between the left and right ends of the portable bed rail and the corresponding left and right ends of the test mattress.

## 7. Test Equipment

### 7.1 Test Beds:

#### 7.1.1 Test Platform 1:

7.1.1.1 *Mattress Construction*—The mattress shall be of standard twin size, 38 by 74.5 in.  $\pm$  0.5 in. (0.97 by 1.89 m  $\pm$  13 mm). The mattress shall be made from open cell polyurethane foam padding and be 4 to 5 in. (102 to 127 mm) thick with a density of 1 lb/ft<sup>3</sup> +0.2, -0 (16 kg/m<sup>3</sup> +3.2, -0). The mattress shall weigh between 6.0 and 9.5 lb (2.7 to 4.3 kg). There shall be no surface texture features (for example, quilting) on the test mattress. The mattress shall be covered with a standard twin sized fitted sheet. The sheet shall be white, 50/50 cotton/polyester blend. It shall have 180 threads per square inch and fabric weight of approximately 3.5 oz/yd<sup>2</sup> (161 g/m<sup>2</sup>). The sheet shall be laundered once before use in an automatic home washer, using hot water setting and longest normal cycle with the manufacturer’s recommended quantity of a commercial detergent, and dried in an automatic home tumble dryer.

7.1.1.2 *Mattress Performance*—The foam shall have an Indentation Load Deflection (ILD)<sup>4</sup> of between 28 and 33 when tested in accordance with Test Methods D 3574, Method B1.

7.1.1.3 *Mattress Support*—The support shall be a common twin sized foundation<sup>5</sup> measuring approximately 6 in. thick by 38 in. by 74.5  $\pm$  0.5 in. (152 mm by 0.97 m by 1.89 m  $\pm$  13 mm). The foundation shall be of typical frame construction that is topped with a rigid board that has a layer of approximately ¼ in. (6 mm) to ⅜ in. (10 mm) of open cell foam and covered with a fabric similar to that of the test mattress. The foundation shall be placed in a common metal bed frame.

#### 7.1.2 Test Platform 2:

7.1.2.1 *Mattress Construction*—The mattress<sup>6</sup> shall be of standard twin size, 38 in. by 74.5 in.  $\pm$  0.5 in. (0.97 m by 1.89 m  $\pm$  13 mm). The mattress shall be of an innerspring design and be between 10.0 in. (0.25 m) and 11.0 in. (0.28 m) thick.<sup>7</sup> The mattress shall weigh 50  $\pm$  10 lb (22.7  $\pm$  4.5 kg). The mattress shall be covered with a standard twin sized cotton fitted sheet. The sheet shall be white, 50/50 cotton/polyester blend. It shall have 180 threads per square inch and fabric weight of approximately 3.5 oz/yd<sup>2</sup> (161 g/m<sup>2</sup>). The sheet shall be laundered once before use in an automatic home washer using hot water setting and longest normal cycle with the manufacturer’s recommended quantity of a commercial detergent, and dried in an automatic home tumble dryer.

7.1.2.2 *Mattress Performance*—The foam shall have an Indentation Load Deflection (ILD)<sup>4</sup> of between 28 and 33 when tested in accordance with Test Methods D 3574, Method B1.

7.1.2.3 *Mattress Support*—The support shall be a common twin sized foundation<sup>5</sup> measuring approximately 6 in. thick by 38 in. by 74.5  $\pm$  0.5 in. (152 mm by 0.97 m by 1.89 m  $\pm$  13 mm). The foundation shall be of typical frame construction that is topped with a rigid board that has a layer of approximately ¼ in. (6.4 mm) to ⅜ in. (9.5 mm) of open cell foam and covered with a fabric similar to that of the test mattress.

#### 7.1.3 Test Platform 3:

7.1.3.1 *Mattress Construction*—The mattress shall be that specified in 7.1.1.1.

7.1.3.2 *Mattress Support*—The support shall be particle board with a nominal thickness of ⅝ by 38 by 74.5 in.

7.2 *Torso Probe*—Block shall be fabricated from sanded hardwood and have a smooth finish. This probe is to be used for the test methods in 8.2 and 8.3 (see Fig. 1(see Fig. 2).

7.3 *Wedge Probe*—Block shall be fabricated from sanded hardwood and have a smooth finish. This probe is to be used for the test method in 8.4 (see Fig. 2(see Fig. 3).

7.4 *Ring Gauge*—A rigid ring with a 1.0-in. (25-mm) O.D. and a 0.625-in. (15.9 mm) I.D. (see Fig. 4). This gauge is used for protrusion testing.

7.5 *Weight Gauge*—A 4.4 lb (2.00 kg) weight. Attached to the weight are a 30-in. (760 mm) loop of cord and a 6-in. (150-mm) loop of cord. The materials are steel and #18 seine twine/mason line (see Fig. 5). This gauge is used for testing protrusions.

## 8. Test Methods

### 8.1 Test Method for Structural Integrity:

8.1.1 Firmly secure the bed rail on a table top or other stationary flat surface using clamps. The clamps should be located 4  $\pm$  1 in. from the intersection of the bedrail legs to the vertical plane (Fig. 7). If the legs of the bed rail move or disengage during testing, re-clamp securely and re-test.

<sup>4</sup> Indentation Load (ILD) is defined as the weight in pounds necessary to deflect a 15 in. square by 4 in. thick piece of foam 1 in.

<sup>5</sup> Suggested foundation to use for this test is Chancellor II Twin Foundation model #1256332.

<sup>6</sup> Suggested mattress to use for this test is Tocarre Firm Twin Mattress model #1640331.

<sup>7</sup> Thickness is measured when the mattress is located on a box spring. Measurement is from the top surface of the box spring to the center of the top-ticking seam.

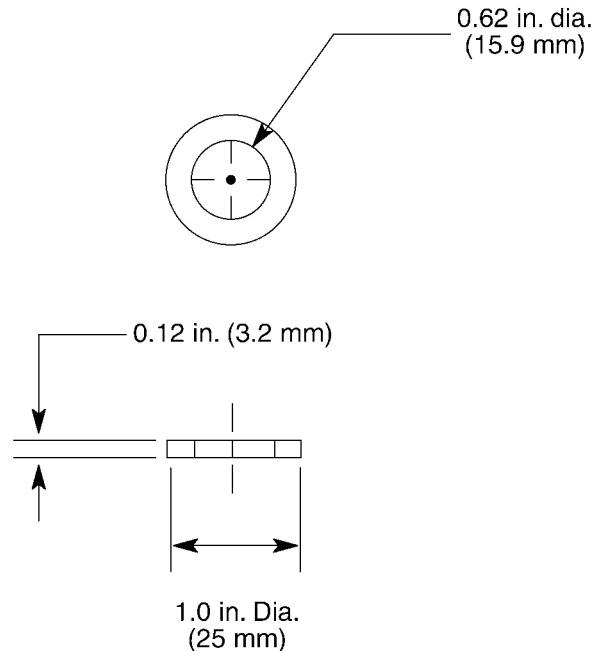

iTeh Standards  
(<https://standards.itih.ai>)  
Document Preview

Material: rigid

FIG. 4 Ring Gauge

ASTM F2085-09

8.1.2 Gradually apply a force of 40 lbf (178 N) at the uppermost horizontal part of the rail in a direction perpendicular to the plane of the rail. The force should be applied in the center along the length of the rail and then repeated with the force applied directly over each of the outermost legs of the bed rail (Fig. 7). The direction of force should be maintained at a 90° angle to the plane of the rail and applied in the direction away from the mattress as if the bed rail were installed on a bed. The force should be applied within a period of 5 s and maintained for an additional 10 s.

8.2 Test Method for Enclosed Openings Within Portable Bed Rail:

8.2.1 Secure bed rail.

8.2.2 Place the Torso Probe shown in Fig. 2 into any opening in the bed rail structure. Place the probe, tapered end first, in the orientation most likely to permit its passage and gradually apply a force of 30 lbf (133 N) in a direction perpendicular to the plane of the opening. Sustain the force for 5 s.

8.3 Test Method for Displacement of Adjacent Style Portable Bed Rails:

8.3.1 Install the portable bed rail on Test Platform 1 in accordance with the manufacturer's instructions. Unless specified otherwise, the bed rail shall be centered along the length of the mattress. Offset the mattress over the mattress support (so that the mattress extends over the edge of the support) 1 in. (25 mm), or as far as the bed rail design allows, up to 1 in. (25 mm).

8.3.2 Starting at one end of the rail, place the tapered end of the Torso Probe shown in Fig. 2 into the intersection of the mattress edge and the face of the rail. Gradually apply sufficient force, not to exceed 30 lbf (133 N), to the probe to create a small gap such that the tapered end enters the gap to a depth of ½-in. (13-mm). Align the probe in the orientation most likely to permit its passage (generally with vertical centerline of the probe as close as possible to perpendicular to the plane of the gap opening).

8.3.3 Gradually apply a pull force of 30 lbf (133 N) vertically downward. Sustain the force for 5 s.

8.3.4 Reinstall the bed rail prior to testing a new location.

8.3.5 Repeat the probe test along the entire length of the bed rail, at intervals not to exceed 12 in. (300 mm) and at locations most likely to fail.

8.3.6 Repeat 8.3.1-8.3.5, with the portable bed rail installed on Test Platform 2.

8.3.7 Repeat 8.3.1-8.3.5, with the portable bed rail installed on Test Platform 3, if applicable.

8.4 Test Method for Displacement of "Mattress-Top" Style Portable Bed Rails: