



SLOVENSKI STANDARD
SIST ISO 6525:2020

01-september-2020

Drsni ležaji - Kolobarjasta oporna podloga, izdelana iz traku - Mere in tolerance

Plain bearings - Ring type thrust washers made from strip - Dimensions and tolerances

Paliers lisses - Rondelles de butée faites à partir de matériaux en bande - Dimensions et tolérances

(standards.iteh.ai)

Ta slovenski standard je istoveten z: ISO 6525:2018

SIST ISO 6525:2020

[https://standards.iteh.ai/catalog/standards/sist/0ff5ad40-f796-4b74-aa66-](https://standards.iteh.ai/catalog/standards/sist/0ff5ad40-f796-4b74-aa66-18f781eeb703/sist-iso-6525-2020)

[18f781eeb703/sist-iso-6525-2020](https://standards.iteh.ai/catalog/standards/sist/0ff5ad40-f796-4b74-aa66-18f781eeb703/sist-iso-6525-2020)

ICS:

21.100.10 Drsni ležaji Plain bearings

SIST ISO 6525:2020

en,fr,de

iTeh STANDARD PREVIEW
(standards.iteh.ai)

SIST ISO 6525:2020

<https://standards.iteh.ai/catalog/standards/sist/0ff5ad40-f796-4b74-aa66-18f781eeb703/sist-iso-6525-2020>

INTERNATIONAL
STANDARD

ISO
6525

Second edition
2018-07

**Plain bearings — Ring type thrust
washers made from strip —
Dimensions and tolerances**

*Paliers lisses — Rondelles de butée faites à partir de matériaux en
bande — Dimensions et tolérances*

iTeh STANDARD PREVIEW
(standards.iteh.ai)

[SIST ISO 6525:2020](https://standards.iteh.ai/catalog/standards/sist/0ff5ad40-f796-4b74-aa66-18f781eeb703/sist-iso-6525-2020)

[https://standards.iteh.ai/catalog/standards/sist/0ff5ad40-f796-4b74-aa66-
18f781eeb703/sist-iso-6525-2020](https://standards.iteh.ai/catalog/standards/sist/0ff5ad40-f796-4b74-aa66-18f781eeb703/sist-iso-6525-2020)



Reference number
ISO 6525:2018(E)

© ISO 2018

iTeh STANDARD PREVIEW (standards.iteh.ai)

SIST ISO 6525:2020

<https://standards.iteh.ai/catalog/standards/sist/0ff5ad40-f796-4b74-aa66-18f781eeb703/sist-iso-6525-2020>



COPYRIGHT PROTECTED DOCUMENT

© ISO 2018

All rights reserved. Unless otherwise specified, or required in the context of its implementation, no part of this publication may be reproduced or utilized otherwise in any form or by any means, electronic or mechanical, including photocopying, or posting on the internet or an intranet, without prior written permission. Permission can be requested from either ISO at the address below or ISO's member body in the country of the requester.

ISO copyright office
CP 401 • Ch. de Blandonnet 8
CH-1214 Vernier, Geneva
Phone: +41 22 749 01 11
Fax: +41 22 749 09 47
Email: copyright@iso.org
Website: www.iso.org

Published in Switzerland

Contents

Page

Foreword	iv
1 Scope	1
2 Normative references	1
3 Terms and definitions	1
4 Symbols and units	2
5 Dimensions and tolerances	2
6 Oil grooves	3
7 Flatness of washer	3
8 Edges	3
Bibliography	7

iTeh STANDARD PREVIEW (standards.iteh.ai)

[SIST ISO 6525:2020](https://standards.iteh.ai/catalog/standards/sist/0ff5ad40-f796-4b74-aa66-18f781eeb703/sist-iso-6525-2020)

<https://standards.iteh.ai/catalog/standards/sist/0ff5ad40-f796-4b74-aa66-18f781eeb703/sist-iso-6525-2020>

ISO 6525:2018(E)

Foreword

ISO (the International Organization for Standardization) is a worldwide federation of national standards bodies (ISO member bodies). The work of preparing International Standards is normally carried out through ISO technical committees. Each member body interested in a subject for which a technical committee has been established has the right to be represented on that committee. International organizations, governmental and non-governmental, in liaison with ISO, also take part in the work. ISO collaborates closely with the International Electrotechnical Commission (IEC) on all matters of electrotechnical standardization.

The procedures used to develop this document and those intended for its further maintenance are described in the ISO/IEC Directives, Part 1. In particular the different approval criteria needed for the different types of ISO documents should be noted. This document was drafted in accordance with the editorial rules of the ISO/IEC Directives, Part 2 (see www.iso.org/directives).

Attention is drawn to the possibility that some of the elements of this document may be the subject of patent rights. ISO shall not be held responsible for identifying any or all such patent rights. Details of any patent rights identified during the development of the document will be in the Introduction and/or on the ISO list of patent declarations received (see www.iso.org/patents).

Any trade name used in this document is information given for the convenience of users and does not constitute an endorsement.

For an explanation on the voluntary nature of standards, the meaning of ISO specific terms and expressions related to conformity assessment, as well as information about ISO's adherence to the World Trade Organization (WTO) principles in the Technical Barriers to Trade (TBT) see the following URL: www.iso.org/iso/foreword.html. (standards.iteh.ai)

This document was prepared by Technical Committee ISO/TC 123, *Plain bearings*, Subcommittee SC 3, *Dimensions, tolerances and construction details*. [SIST ISO 6525:2020](https://standards.iteh.ai/catalog/standards/sist/0ff5ad40-f796-4b74-aa66-3d8771000000/iso-6525-2020)

Any feedback or questions on this document should be directed to the user's national standards body. A complete listing of these bodies can be found at www.iso.org/members.html.

This second edition cancels and replaces the first edition (ISO 6525:1983), which has been technically revised. The main changes compared to the previous edition are as follows:

- Normative references have been updated.
- The illustration of the recess in Figure 1 has been improved.

Plain bearings — Ring type thrust washers made from strip — Dimensions and tolerances

1 Scope

This document specifies a range of ring type thrust washers for general purpose use with wrapped bushes as specified in ISO 3547 (all parts).

It applies to thrust washers having inside diameters from 6 to 80 mm.

NOTE It is not expected that all the sizes listed will be available from stock but the standardization of sizes is aimed at making economies in tooling costs.

2 Normative references

There are no normative references in this document.

3 Terms and definitions

For the purposes of this document, the following terms and definitions apply.

ISO and IEC maintain terminological databases for use in standardization at the following addresses:

- ISO Online browsing platform: available at <https://www.iso.org/obp>
- IEC Electropedia: available at <http://www.electropedia.org/>

3.1

ring type thrust washer

unsplit ring, normally fitting into a recess in the end of a housing, which is intended to accept thrust and to provide axial location for a rotating shaft

Note 1 to entry: The standardized thrust washers are prevented from rotating by a dowel. Other means of location such as a lug or tab may be provided in place of a dowel.

Note 2 to entry: See [Figure 1](#).

ISO 6525:2018(E)

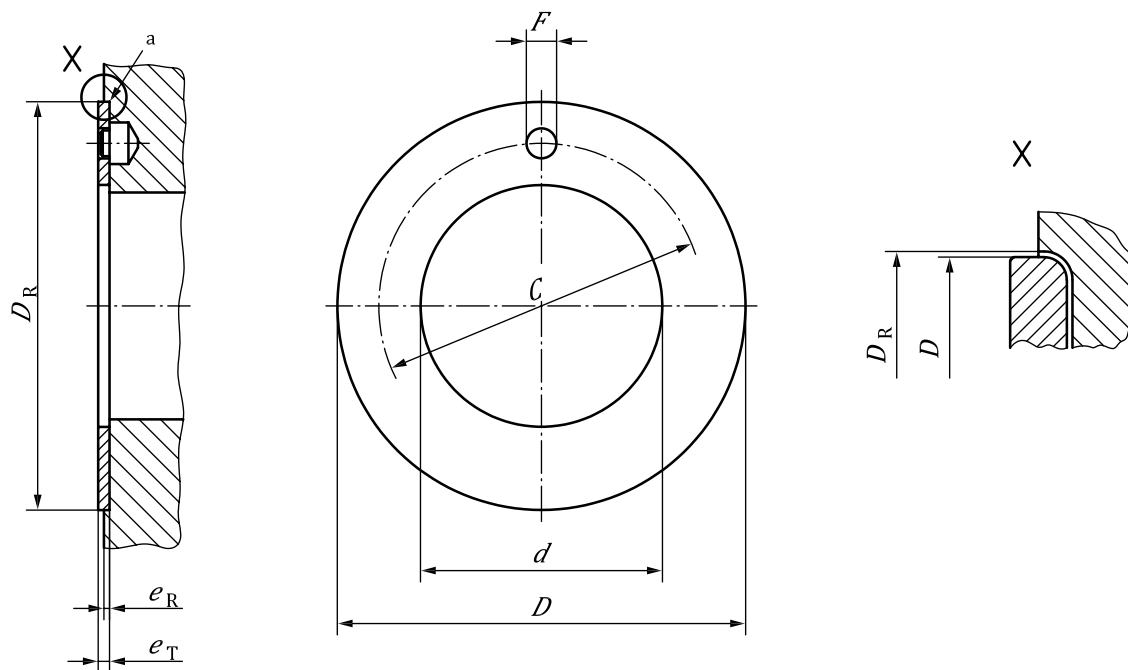

NOTE The symbols are as defined in Table 1.

a Inside corner of recess to be sharp or undercut to avoid collision with outside corner of washer.

Figure 1 — Ring type thrust washer

SIST ISO 6525:2020

4 Symbols and units

<https://standards.iteh.ai/catalog/standards/sist/0ff5ad40-f796-4b74-aa66-18f781eeb703/sist-iso-6525-2020>

See Table 1.

Table 1 — Symbols and units

Symbol	Description	Unit
C	pitch circle diameter for dowel centre	mm
D	outside diameter of the washer	mm
D_R	diameter of recess in the housing	mm
d	inside diameter of the washer	mm
e_R	depth of recess in the housing	mm
e_T	total washer thickness	mm
F	dowel hole diameter	mm
p	flatness limit	mm

5 Dimensions and tolerances

The basic dimensions and tolerances for thrust washers are shown in Table 2.

Dimension D_R is equal to D and the tolerance for D_R is G10.

Dimension e_R is determined by the possible wear of the thrust washer, axial clearance and the condition of loading in order to prevent washer escaping out of the recess if the load is reversed.

6 Oil grooves

By agreement between the user and the manufacturer, oil grooves may be provided.

Grooves serve the primary purpose of feeding oil over the flat areas. Sometimes, however, grooves have to be deeper than is necessary for this purpose in order to allow escape of oil from pressure-fed journal bearings. Some typical grooving arrangements are illustrated in [Figure 2](#).

When grooves are embossed into bimetallic materials, the depth of groove should preferably be less than the lining thickness.

Sharp edges of grooves shall be removed.

7 Flatness of washer

It is not possible to specify flatness for thrust washers having oil grooving on the thrust face since the grooving operation causes distortion. In the special case of ungrooved washers, they shall slide between parallel plates set at $e_{Tmax} + p$ where $p = 0,10$ mm for up to 80 mm outside diameter and $p = 0,12$ mm above this diameter.

8 Edges

All sharp edges shall be removed.

iTeh STANDARD PREVIEW
(standards.iteh.ai)

[SIST ISO 6525:2020](#)

<https://standards.iteh.ai/catalog/standards/sist/0ff5ad40-f796-4b74-aa66-18f781eeb703/sist-iso-6525-2020>