



~~Designation: G32-06~~ Designation: G 32 – 09

## Standard Test Method for Cavitation Erosion Using Vibratory Apparatus<sup>1</sup>

This standard is issued under the fixed designation G 32; the number immediately following the designation indicates the year of original adoption or, in the case of revision, the year of last revision. A number in parentheses indicates the year of last reappraisal. A superscript epsilon ( $\epsilon$ ) indicates an editorial change since the last revision or reappraisal.

### 1. Scope

1.1 This test method ~~produces~~ covers the production of cavitation damage on the face of a specimen vibrated at high frequency while immersed in a liquid. The vibration induces the formation and collapse of cavities in the liquid, and the collapsing cavities produce the damage to and erosion (material loss) of the specimen.

1.2 Although the mechanism for generating fluid cavitation in this method differs from that occurring in flowing systems and hydraulic machines (see 5.1), the nature of the material damage mechanism is believed to be basically similar. The method therefore offers a small-scale, relatively simple and controllable test that can be used to compare the cavitation erosion resistance of different materials, to study in detail the nature and progress of damage in a given material, or—by varying some of the test conditions—to study the effect of test variables on the damage produced.

1.3 This test method specifies standard test conditions covering the diameter, vibratory amplitude and frequency of the specimen, as well as the test liquid and its container. It permits deviations from some of these conditions if properly documented, that may be appropriate for some purposes. It gives guidance on setting up a suitable apparatus and covers test and reporting procedures and precautions to be taken. It also specifies standard reference materials that must be used to verify the operation of the facility and to define the normalized erosion resistance of other test materials.

~~1.4 The values stated in SI units are to be regarded as standard. The inch-pound units given in parentheses are for information only.~~

~~1.5~~

~~1.4~~ A history of this test method is given in Appendix X3, followed by a comprehensive bibliography.

~~1.5 The values stated in SI units are to be regarded as standard. The inch-pound units given in parentheses are for information only.~~

~~1.6 This standard does not purport to address all of the safety concerns, if any, associated with its use. It is the responsibility of the user of this standard to establish appropriate safety and health practices and determine the applicability of regulatory limitations prior to use. For specific safety precautionary warning information, see 6.1, 10.3, and 10.6.1.~~

### 2. Referenced Documents

2.1 ~~ASTM Standards:<sup>2</sup>~~ <http://standards.iteh.ai/catalog/standards/sist/eca45b6f-b12e-4c49-8c17-b878e549c30c/astm-g32-09>

A 276 [Specification for Stainless Steel Bars and Shapes](#)

B 160 [Specification for Nickel Rod and Bar](#)

B 211 [Specification for Aluminum and Aluminum-Alloy Bar, Rod, and Wire](#)

D 1193 [Specification for Reagent Water](#)

E 177 [Practice for Use of the Terms Precision and Bias in ASTM Test Methods](#)

E 691 [Practice for Conducting an Interlaboratory Study to Determine the Precision of a Test Method](#)

E 960 [Specification for Laboratory Glass Beakers](#)

G 40 [Terminology Relating to Wear and Erosion](#)

G 73 [Practice for Liquid Impingement Erosion Testing](#)

G 117 [Guide for Calculating and Reporting Measures of Precision Using Data from Interlaboratory Wear or Erosion Tests](#)

G 119 [Guide for Determining Synergism Between Wear and Corrosion](#)

G 134 [Test Method for Erosion of Solid Materials by a Cavitating Liquid Jet](#)

<sup>1</sup> This test method is under the jurisdiction of ASTM Committee G02 on Wear and Erosion and is the direct responsibility of Subcommittee G02.10 on Erosion by Solids and Liquids.

Current edition approved Dec. May 1, 2006-2009. Published January 2007-May 2009. Originally approved in 1972. Last previous edition approved in 2003-2006 as G32-03-G 32-06.

<sup>2</sup> For referenced ASTM standards, visit the ASTM website, www.astm.org, or contact ASTM Customer Service at service@astm.org. For *Annual Book of ASTM Standards* volume information, refer to the standard's Document Summary page on the ASTM website.

### 3. Terminology

#### 3.1 Definitions:

3.1.1 See Terminology G 40 for definitions of terms relating to cavitation erosion. For convenience, important definitions for this standard are listed below; some are slightly modified from Terminology G 40 or not contained therein.

3.1.2 *average erosion rate, n*—a less preferred term for cumulative erosion rate.

3.1.3 *cavitation, n*—the formation and subsequent collapse, within a liquid, of cavities or bubbles that contain vapor or a mixture of vapor and gas.

3.1.3.1 *Discussion*—In general, cavitation originates from a local decrease in hydrostatic pressure in the liquid, produced by motion of the liquid (see *flow cavitation*) or of a solid boundary (see *vibratory cavitation*). It is distinguished in this way from boiling, which originates from an increase in liquid temperature.

3.1.3.2 *Discussion*—The term cavitation, by itself, should not be used to denote the damage or erosion of a solid surface that can be caused by it; this effect of cavitation is termed *cavitation damage* or *cavitation erosion*. To erode a solid surface, bubbles or cavities must collapse on or near that surface.

3.1.4 *cavitation erosion, n*—progressive loss of original material from a solid surface due to continued exposure to cavitation.

3.1.5 *cumulative erosion, n*—the total amount of material lost from a solid surface during all exposure periods since it was first exposed to cavitation or impingement as a newly finished surface. (More specific terms that may be used are *cumulative mass loss*, *cumulative volume loss*, or *cumulative mean depth of erosion*. See also *cumulative erosion-time curve*.)

3.1.5.1 *Discussion*—Unless otherwise indicated by the context, it is implied that the conditions of cavitation or impingement have remained the same throughout all exposure periods, with no intermediate refinishing of the surface.

3.1.6 *cumulative erosion rate, n*—the cumulative erosion at a specified point in an erosion test divided by the corresponding cumulative exposure duration; that is, the slope of a line from the origin to the specified point on the cumulative erosion-time curve. (*Synonym: average erosion rate*)

3.1.7 *cumulative erosion-time curve*—a plot of cumulative erosion versus cumulative exposure duration, usually determined by periodic interruption of the test and weighing of the specimen. This is the primary record of an erosion test. Most other characteristics, such as the incubation period, maximum erosion rate, terminal erosion rate, and erosion rate-time curve, are derived from it.

3.1.8 *erosion rate-time curve, n*—a plot of instantaneous erosion rate versus exposure duration, usually obtained by numerical or graphical differentiation of the cumulative erosion-time curve. (See also *erosion rate-time pattern*.)

3.1.9 *erosion rate-time pattern, n*—any qualitative description of the shape of the erosion rate-time curve in terms of the several stages of which it may be composed.

3.1.9.1 *Discussion*—In cavitation and liquid impingement erosion, a typical pattern may be composed of all or some of the following “periods” or “stages”: *incubation period*, *acceleration period*, *maximum-rate period*, *deceleration period*, *terminal period*, and occasionally *catastrophic period*. The generic term “period” is recommended when associated with quantitative measures of its duration, etc.; for purely qualitative descriptions the term “stage” is preferred.

3.1.10 *erosion threshold time, n*—the exposure time required to reach a mean depth of erosion of 1.0  $\mu\text{m}$ .

3.1.10.1 *Discussion*—A mean depth of erosion of 1.0  $\mu\text{m}$  is the least accurately measurable value considering the precision of the scale, specimen diameter, and density of the standard reference material.

3.1.11 *flow cavitation, n*—cavitation caused by a decrease in local pressure induced by changes in velocity of a flowing liquid, such as in flow around an obstacle or through a constriction.

3.1.12 *incubation period, n*—the initial stage of the erosion rate-time pattern during which the erosion rate is zero or negligible compared to later stages.

~~3.1.11.1~~

3.1.12.1 *Discussion*—The incubation period is usually thought to represent the accumulation of plastic deformation and internal stresses under the surface, that precedes significant material loss. There is no exact measure of the duration of the incubation period. See related terms, *erosion threshold time* and *nominal incubation period*.

~~3.1.12~~

3.1.13 *maximum erosion rate, n*—the maximum instantaneous erosion rate in a test that exhibits such a maximum followed by decreasing erosion rates. (See also *erosion rate-time pattern*.)

~~3.1.12.1~~

3.1.13.1 *Discussion*—Occurrence of such a maximum is typical of many cavitation and liquid impingement tests. In some instances it occurs as an instantaneous maximum, in others as a steady-state maximum which persists for some time.

~~3.1.13~~

3.1.14 *mean depth of erosion (MDE), n*—the average thickness of material eroded from a specified surface area, usually calculated by dividing the measured mass loss by the density of the material to obtain the volume loss and dividing that by the area of the specified surface. (Also known as *mean depth of penetration* or *MDP*. Since that might be taken to denote the average value of the depths of individual pits, it is a less preferred term.)

~~3.1.14~~

3.1.15 *nominal incubation time, n*—the intercept on the time or exposure axis of the straight-line extension of the

maximum-slope portion of the cumulative erosion-time curve; while this is not a true measure of the incubation stage, it serves to locate the maximum erosion rate line on the cumulative erosion versus time coordinates.

3.1.15

3.1.16 *normalized erosion resistance,  $N_e, n$* —a measure of the erosion resistance of a test material relative to that of a specified reference material, calculated by dividing the volume loss rate of the reference material by that of the test material, when both are similarly tested and similarly analyzed. By “similarly analyzed” is meant that the two erosion rates must be determined for corresponding portions of the erosion rate time pattern; for instance, the maximum erosion rate or the terminal erosion rate.

3.1.15.1

3.1.16.1 *Discussion*—A recommended complete wording has the form, “The normalized erosion resistance of (test material) relative to (reference material) based on (criterion of data analysis) is (numerical value).”

3.1.16

3.1.17 *normalized incubation resistance  $N_o, n$* —the nominal incubation time of a test material, divided by the nominal incubation time of a specified reference material similarly tested and similarly analyzed. (See also *normalized erosion resistance*.)

3.1.17

3.1.18 *tangent erosion rate,  $n$* —the slope of a straight line drawn through the origin and tangent to the knee of the cumulative erosion-time curve, when that curve has the characteristic S-shaped pattern that permits this. In such cases, the tangent erosion rate also represents the maximum cumulative erosion rate exhibited during the test.

3.1.18

3.1.19 *terminal erosion rate,  $n$* —the final steady-state erosion rate that is reached (or appears to be approached asymptotically) after the erosion rate has declined from its maximum value. (See also *terminal period* and *erosion rate-time pattern*.)

3.1.19

3.1.20 *vibratory cavitation,  $n$* —cavitation caused by the pressure fluctuations within a liquid, induced by the vibration of a solid surface immersed in the liquid.

#### 4. Summary of Test Method

4.1 This test method generally utilizes a commercially obtained 20-kHz ultrasonic transducer to which is attached a suitably designed “horn” or velocity transformer. A specimen button of proper mass is attached by threading into the tip of the horn.

4.2 The specimen is immersed into a container of the test liquid (generally distilled water) that must be maintained at a specified temperature during test operation, while the specimen is vibrated at a specified amplitude. The amplitude and frequency of vibration of the test specimen must be accurately controlled and monitored.

4.3 The test specimen is weighed accurately before testing begins and again during periodic interruptions of the test, in order to obtain a history of mass loss versus time (which is not linear). Appropriate interpretation of this cumulative erosion-versus-time curve permits comparison of results between different materials or between different test fluids or other conditions.

#### 5. Significance and Use

5.1 This test method may be used to estimate the relative resistance of materials to cavitation erosion as may be encountered, for instance, in pumps, hydraulic turbines, hydraulic dynamometers, valves, bearings, diesel engine cylinder liners, ship propellers, hydrofoils, and in internal flow passages with obstructions. An alternative method for similar purposes is Test Method ~~G134~~, G 134, which employs a cavitating liquid jet to produce erosion on a stationary specimen. The latter may be more suitable for materials not readily formed into a precisely shaped specimen. The results of either, or *any*, cavitation erosion test should be used with caution; see 5.8.

5.2 Some investigators have also used this test method as a screening test for materials subjected to liquid impingement erosion as encountered, for instance, in low-pressure steam turbines and in aircraft, missiles or spacecraft flying through rainstorms. Practice G 73 describes another testing approach specifically intended for that type of environment.

5.3 This test method is not recommended for evaluating elastomeric or compliant coatings, some of which have been successfully used for protection against cavitation or liquid impingement of moderate intensity. This is because the compliance of the coating on the specimen may reduce the severity of the liquid cavitation induced by its vibratory motion. The result would not be representative of a field application, where the hydrodynamic generation of cavitation is independent of the coating.

NOTE 1—An alternative approach that uses the same basic apparatus, and is deemed suitable for compliant coatings, is the “stationary specimen” method. In that method, the specimen is fixed within the liquid container, and the vibrating tip of the horn is placed in close proximity to it. The cavitation “bubbles” induced by the horn (usually fitted with a highly resistant replaceable tip) act on the specimen. While several investigators have used this approach (see X3.2.3), they have differed with regard to standoff distances and other arrangements. The stationary specimen approach can also be used for brittle materials which can not be formed into a threaded specimen nor into a disc that can be cemented to a threaded specimen, as required for this test method (see 7.6).

5.4 This test method should not be directly used to rank materials for applications where electrochemical corrosion or solid particle impingement plays a major role. However, adaptations of the basic method and apparatus have been used for such purposes (see 9.2.5, 9.2.6, and X3.2). Guide G 119 may be followed in order to determine the synergism between the mechanical and electrochemical effects.

5.5 Those who are engaged in basic research, or concerned with very specialized applications, may need to vary some of the

test parameters to suit their purposes. However, adherence to this test method in all other respects will permit a better understanding and correlation between the results of different investigators.

5.6 Because of the nonlinear nature of the erosion-versus-time curve in cavitation and liquid impingement erosion, the shape of that curve must be considered in making comparisons and drawing conclusions. See Section 11.

5.7 The results of this test may be significantly affected by the specimen's surface preparation. This must be considered in planning, conducting and reporting a test program. See also 7.4 and 12.2.

5.8 The mechanisms of cavitation erosion and liquid impingement erosion are not fully understood and may differ, depending on the detailed nature, scale, and intensity of the liquid/solid interactions. "Erosion resistance" may, therefore, represent a mix of properties rather than a single property, and has not yet been successfully correlated with other independently measurable material properties. For this reason, the consistency of results between different test methods or under different field conditions is not very good. Small differences between two materials are probably not significant, and their relative ranking could well be reversed in another test.

**6. Apparatus**

6.1 The vibratory apparatus used for this test method produces axial oscillations of a test specimen inserted to a specified depth in the test liquid. The vibrations are generated by a magnetostrictive or piezoelectric transducer, driven by a suitable electronic oscillator and power amplifier. The power of the system should be sufficient to permit constant amplitude of the specimen in air as well as submerged. An acoustic power output of 250 to 1000 W has been found suitable. Such systems are commercially available, intended for ultrasonic welding, emulsifying, and so forth.<sup>3</sup> (**Warning**—This apparatus may generate high sound levels. The use of ear protection may be necessary. Provision of an acoustical enclosure is recommended.)

6.1.1 The basic parameters involved in this test method are pictorially shown in Fig. 1. Schematic and photographic views of representative equipment are shown in Figs. 2 and 3 respectively.

6.2 To obtain a higher vibratory amplitude at the specimen than at the transducer, a suitably shaped tapered cylindrical member, generally termed the "horn" or "velocity transformer," is required. Catenoidal, exponential and stepped horn profiles have been used for this application. The diameter of the horn at its tip shall conform to that specified for the specimen (see 7.1).

6.3 The test specimen (see also Section 7 and Fig. 4) is shaped as a button with the same outer diameter as the horn tip, and has a smaller diameter threaded shank, which is screwed into a threaded hole at the end of the horn. The depth of the hole in the horn shall be the minimum consistent with the required length of engagement of the specimen shank.

6.4 The transducer and horn assembly shall be supported in a manner that does not interfere with, and receives no force input from, the vibratory motion. This can be accomplished, for example, by attaching the support structure to a stationary housing of the transducer, or to a flange located at a nodal plane of the vibrating assembly. It is also necessary to prevent any misalignment of the horn due to forces caused by the electrical cable, cooling system, or transducer enclosure.

6.5 *Frequency Control:*

<sup>3</sup> Several manufacturers of ultrasonic processing or plastics welding equipment offer apparatus off-the-shelf, or specially modified, to meet the specifications given in this standard. A list of those known to the subcommittee having jurisdiction is available from its chairman. Inclusion in this list does not imply such equipment has been qualified in a test program.

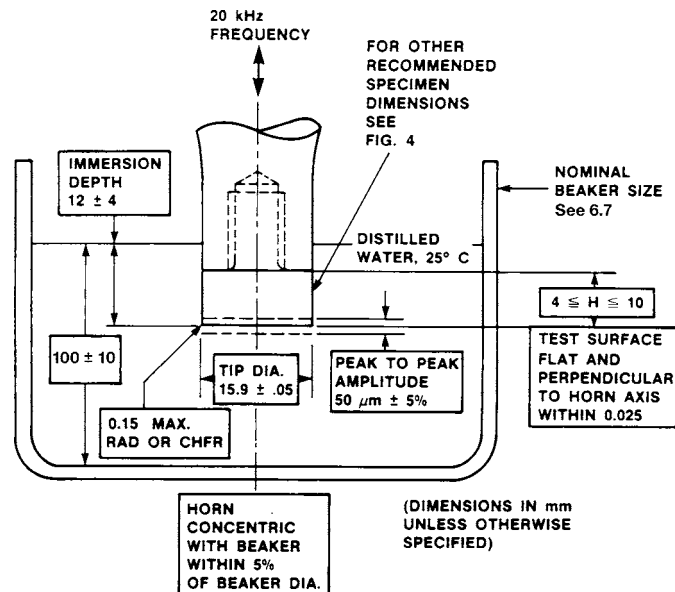

FIG. 1 Important Parameters of the Vibratory Cavitation Test

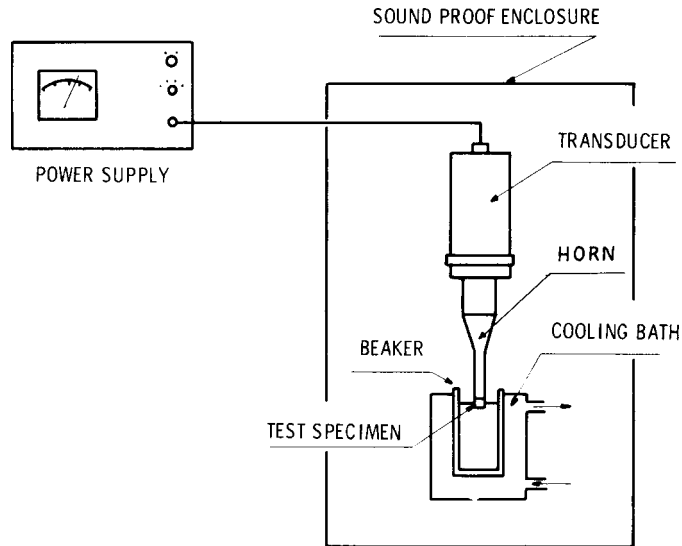

FIG. 2 Schematic of Vibratory Cavitation Erosion Apparatus

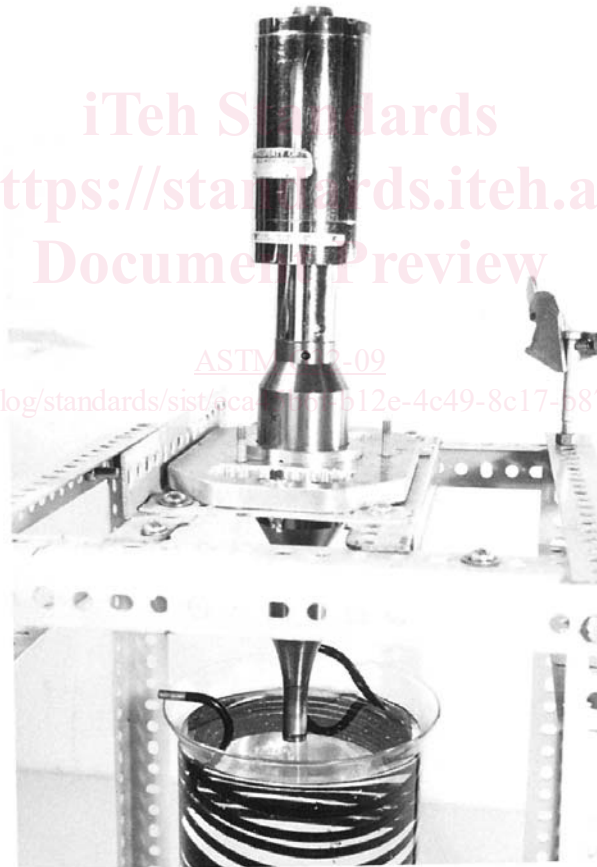

FIG. 3 Photograph of a Typical Apparatus

6.5.1 The frequency of oscillation of the test specimen shall be  $20 \pm 0.5$  kHz.

6.5.2 The whole transducer-horn-specimen system shall be designed for longitudinal resonance at this frequency.

NOTE 2—If both light and heavy alloys are to be tested, then two horns of different length may be needed in order to permit use of similarly sized specimens. One horn might be used for specimens having densities  $5 \text{ g/cm}^3$  or more and tuned for a button mass of about 10 g (0.022 lb), and the other for densities less than  $5 \text{ g/cm}^3$ , tuned for a button mass of about 5 g (0.011 lb). See also 7.2 and Table X2.2 and Table X2.2.

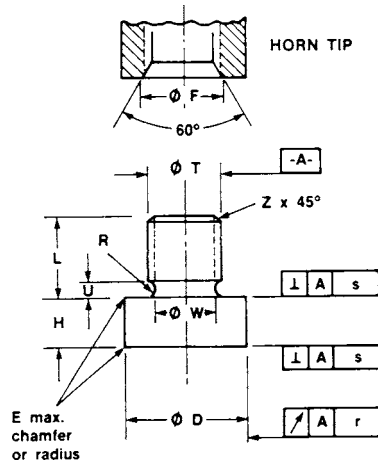

TABLE OF VALUES

|    | mm                               | inch              |
|----|----------------------------------|-------------------|
| D* | 15.9 ± 0.05                      | 0.624 ± 0.002     |
| E* | 0.15                             | 0.006             |
| F  | (W + 2.2) ± 0.25                 | (W + 0.09) ± 0.01 |
| H  | See Paragraph 7.2                |                   |
| H  | See 7.2                          |                   |
| L  | 10.0 ± 0.5                       | 0.394 ± 0.02      |
| R  | 0.8 ± 0.15                       | 0.031 ± 0.006     |
| T  | Thread, see Paragraph X2.2.1     |                   |
| T  | Thread, see X2.2.1               |                   |
| U  | 2.0 ± 0.5                        | 0.08 ± 0.02       |
| W  | Thread minor dia, see Table X2.2 |                   |
| W  | Thread minor dia, see Table X2.2 |                   |
| Z  | 0.8 ± 0.15                       | 0.031 ± 0.006     |
| r* | 0.050                            | 0.002             |
| s* | 0.025                            | 0.001             |

NOTE—Asterisk (\*) indicates mandatory; others recommended.

FIG. 4 Dimensions and Tolerances of the Test Specimen

6.5.3 A means for monitoring or checking frequency shall be provided; this could be a signal from the power supply or a transducer, feeding into a frequency counter.

6.6 Amplitude Control:

6.6.1 Means shall be provided to measure and control vibration amplitude of the horn tip within the tolerances specified in 9.1.1.7 or 9.1.2.

6.6.2 If the ultrasonic system has automatic control to maintain resonance and constant amplitude, amplitude calibration may be done with the specimen in the air and will still apply when the specimen is submerged. This may be done with a filar microscope, dial indicator, eddy-current displacement sensor, or other suitable means (see also Appendix X1).

6.6.3 If the apparatus does not have automatic amplitude control, it may be necessary to provide a strain gage or accelerometer on some part of the vibrating assembly for continuous monitoring.

6.7 Liquid Vessel:

6.7.1 The size of the vessel containing the test liquid is a compromise. It must be small enough to permit satisfactory temperature control, and large enough to avoid possible effects of wave reflections from its boundaries, and of erosion debris.

6.7.2 The vessel shall be cylindrical in cross-section, and the depth of liquid in it shall be 100 ± 10 mm.

6.7.3 The vessel's inside diameter will depend on whether the cooling method (see 6.8) is an external cooling bath into which the vessel is immersed, or a cooling coil immersed within the vessel. In either case, the unobstructed diameter should be 100 ± 15 mm.

6.7.4 A standard commercially available low-form glass beaker (for example, Type I or II of Specification E 960) may be suitable. A 600-mL beaker may be suitable when a cooling bath is used, and a 1000-mL to 1500-mL beaker when a cooling coil is used.

6.8 Means shall be provided to maintain the temperature of the test liquid near the specimen at a specified temperature (see 9.1.1.5). This is commonly achieved by means of a cooling bath around the liquid-containing vessel or a cooling coil immersed within it, with suitable thermostatic control. The temperature sensor should be located as close as practicable to the specimen, but at a point where it does not interfere with the cavitation process and is not damaged by it. A suggested location is approximately