



~~Designation: G143-03 (Reapproved 2004)~~ Designation: G 143 – 03 (Reapproved 2009)

## Standard Test Method for Measurement of Web/Roller Friction Characteristics<sup>1</sup>

This standard is issued under the fixed designation G 143; the number immediately following the designation indicates the year of original adoption or, in the case of revision, the year of last revision. A number in parentheses indicates the year of last reapproval. A superscript epsilon ( $\epsilon$ ) indicates an editorial change since the last revision or reapproval.

### 1. Scope

1.1 This test method covers the simulation of a roller/web transport tribosystem and the measurement of the static and kinetic coefficient of friction of the web/roller couple when sliding occurs between the two. The objective of this test method is to provide users with web/roller friction information that can be used for process control, design calculations, and for any other function where web/roller friction needs to be known.

~~1.2 The values stated in SI units are to be regarded as the standard. The values given in parentheses are for information only.~~

1.2 The values stated in SI units are to be regarded as standard. No other units of measurement are included in this standard.

1.3 *This standard does not purport to address all of the safety concerns, if any, associated with its use. It is the responsibility of the user of this standard to establish appropriate safety and health practices and determine the applicability of regulatory limitations prior to use.*

### 2. Referenced Documents

2.1 ~~ASTM Standards:~~

~~D 883~~ ASTM Standards:<sup>2</sup>

D 883 Terminology Relating to Plastics

D 1894 Test Method for Static and Kinetic Coefficients of Friction of Plastic Film and Sheet

D 3108 Test Method for Coefficient of Friction, Yarn to Solid Material

E 8 Test Methods for Tension Testing of Metallic Materials

E 122 Practice for Choice of Calculating Sample Size to Estimate, With a Specified Tolerable Error, Precision, the Average for a Characteristic of a Lot or Process

E 177 Practice for Use of the Terms Precision and Bias in ASTM Test Methods

E 691 Practice for Conducting an Interlaboratory Study to Determine the Precision of a Test Method

G 40

G 40 Terminology Relating to Wear and Erosion

G 115 Guide for Measuring and Reporting Friction Coefficients

G 117 Guide for Calculating and Reporting Measures of Precision Using Data from Interlaboratory Wear or Erosion Tests

G 163

G 163 Guide for Digital Data Acquisition in Wear and Friction Measurements

### 3. Terminology

3.1 *Definitions of Terms Specific to This Standard:*

3.1.1 *blocking, n*—unintentional adhesion between plastic films or between a film and another surface. **D 883**

3.1.2 *coefficient of friction,  $\mu$ , n*—in tribology—the dimensionless ratio of the friction force ( $F$ ) between two bodies to the normal force ( $N$ ) pressing these bodies together. **G 40**

3.1.3 *friction force, n*—the resisting force tangential to the interface between two bodies when, under the action of external force, one body moves or tends to move relative to the other. **G 40**

3.1.4 *kinetic coefficient of friction, n*—the coefficient of friction under conditions of macroscopic relative motion between two bodies. **G 40**

3.1.5 *stick-slip, n*—a cyclic fluctuation in the magnitudes of friction force and relative velocity between two elements in sliding contact, usually associated with a relaxation oscillation dependent on elasticity in the tribosystem and on a decrease of the

<sup>1</sup> This test method is under the jurisdiction of ASTM Committee G02 on Wear and Erosion and is the direct responsibility of Subcommittee G02.50 on Friction.

Current edition approved ~~Nov 1, 2004~~ May 1, 2009. Published ~~November 2004~~ May 2009. Originally approved in 1996. Last previous edition approved in ~~2003~~ 2004 as ~~G143-03-G 143-03(2004)~~.

<sup>2</sup> For referenced ASTM standards, visit the ASTM website, www.astm.org, or contact ASTM Customer Service at service@astm.org. For *Annual Book of ASTM Standards* volume information, refer to the standard's Document Summary page on the ASTM website.

coefficient of friction with onset of sliding or with increase of sliding velocity.

G 40

3.1.5.1 *Discussion*—Classical or true stick-slip, in which each cycle consists of a stage of actual stick followed by a stage of overshoot slip, requires that the kinetic coefficient is lower than the static coefficient. A modified form of relaxation oscillation, with near-harmonic fluctuation in motion, can occur when the kinetic coefficient of friction decreases gradually with increasing velocity within a certain velocity range. A third type of stick-slip can be due to spatial periodicity of the friction coefficient along the path of contact. Random variations in friction force measurement do not constitute stick-slip.

3.1.6 *triboelement, n*—one of two or more solid bodies which comprise a sliding, rolling, or abrasive contact, or a body subjected to impingement or cavitation.

G 40

3.1.6.1 *Discussion*—Contacting triboelements may be in direct contact, or may be separated by an intervening lubricant, oxide, or other film that affects tribological interactions between them.

3.1.7 *tribosystem, n*—any system that contains one or more triboelements, including all mechanical, chemical, and environmental factors relevant to tribological behavior.

G 40

#### 4. Summary of Test Method

4.1 This test method can be used to measure the friction characteristics of a flexible web as it slides on a cylindrical surface. The web conforms to the cylindrical surface in the area of wrap.

4.2 The test method is conducted on a narrow web or strip taken from a web of interest. One end of the strip is draped over a stationary cylinder and the other end is affixed to a force measuring device. A mass is applied to the free end of the strip and the strip is pulled by a mechanism that moves the force transducer perpendicular to the long axis of the cylindrical surface. The force encountered in pulling the strip in contact with the stationary cylinder (roller) is continuously measured and recorded. The static and kinetic coefficients of friction are calculated from the force measured by the force transducer.

#### 5. Significance and Use

5.1 This test method is intended to simulate the slip of a flexible web on a roller in a machine or tribosystem that conveys web materials. Flexible webs such as plastic sheeting, paper, elastomers, metal foils, and cloth are often transported in manufacturing processes by combinations of driving and idler rollers. The friction characteristics of the web/roller interface often affects the web transport process. If the web/roller friction is too low, the web can slip on the rollers and be damaged or damage the roller. High friction on the other hand, can lead to steering problems and overloading of driving motors.

5.2 This test method can be used to rank rollers for their ability to resist slip versus a particular web material (high friction). Conversely this test method can assess web materials or web surface coatings such as waxes and lubricants. In this latter case, the goal may be a low-friction product made from a web (film, magnetic media, paper, and so forth).

5.3 If a tribosystem involves transport of a flexible web on a roller, this is an appropriate test to use to measure the friction characteristics of the roller/web couple.

#### 6. Apparatus

ASTM G143-03(2009)

6.1 Two possible configurations of the test are shown in Figs. 1 and 2. The essential features of the apparatus are:

- 6.1.1 A force measuring device attached to one member of the friction couple,
- 6.1.2 A stationary cylindrical surface to be used as one member of the friction couple,
- 6.1.3 A system to move the flexible strip (web) member of the friction couple, and
- 6.1.4 Masses to be used to tension the free end of the test strip.

6.2 *Force Measurement*—Commercially available or homemade strain gage or similar force transducers are acceptable. The device should be linear in the force range anticipated in testing and the transducer shall be calibrated with known masses or a similar system for each use.

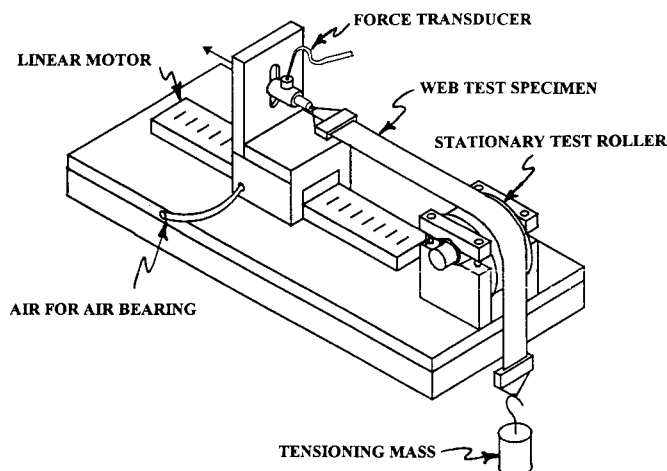

FIG. 1 Schematic of Capstan Friction Test

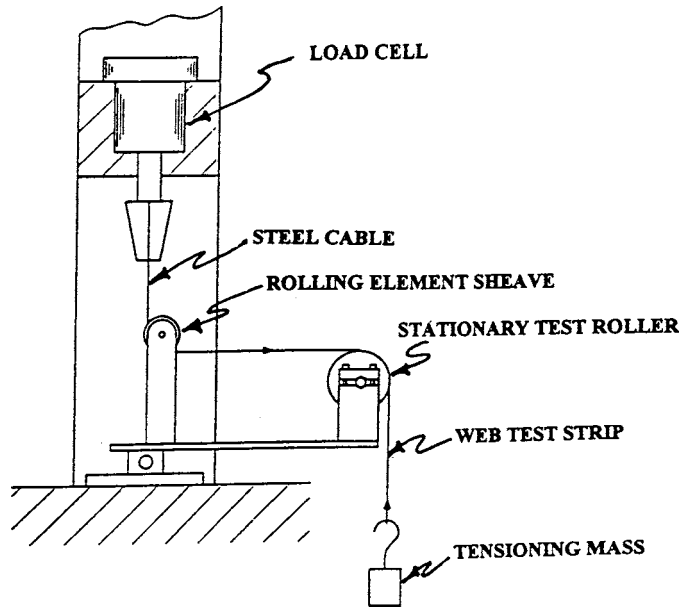

FIG. 2 Use of Tensile Test Machine to Perform the Capstan Friction Test

6.2.1 Force transducers shall be accurate within 1 % of the rated scale of the device and should have overload protection. The friction force during the entire test should be recorded. (**Warning**—Digital filters can alter the force data to the point where the data are not valid. Analog strip chart recorders have been shown to be acceptable recording devices for this test method. (See Guide G 163 for details on digital data acquisition))

6.3 *Cylindrical Surface*—The recommended diameter of the test cylinder should be the same diameter as the rollers or curved surface that is simulated in the friction test. The cylinder surface texture and material of construction should be the same as the tribosystem of interest. If materials are being evaluated without simulating a particular tribosystem, the test roller can be the same as the roller used in the interlaboratory tests of this test method: 100-mm diameter (100 mm long), 50- $\mu$ m thick hard coated (thick hard anodize) 6061-T6 aluminum with a surface roughness of 0.75 to 1  $\mu$ m Ra (measured parallel to the cylinder’s axis; surface was lathe generated).

6.4 *Sliding Motion*—The device shown schematically in Fig. 1 uses a linear motor to pull the test strip. The cylinder is stationary. Any device with controlled acceleration and velocity is acceptable. A ball screw driven by a variable speed motor is suitable as is the crosshead on a tensile testing machine. In the latter case, it may be necessary to use a sheave with a free-wheeling rolling element bearing to transfer the motion from a vertical to horizontal plane (see Fig. 2).

NOTE 1—Some devices rotate the cylinder and hold the web with a force transducer. This was done in interlaboratory tests and produced the same results as pulling the web over a stationary cylinder.

6.5 *Tensioning Mass*—Ordinary masses from balances and similar laboratory equipment are suitable for tensioning. It is imperative to attach the masses and the friction transducers with a device that prevents lateral motion of the test strip. Bridle devices such as the one shown in Fig. 3 allow a straight pull of the test strip. If lateral slip occurs in a particular test, the results will probably be different from a test in which this unwanted slip does not occur.

6.6 *Test Environment*—The friction characteristics of some web/roller couples can be affected by the ambient temperature and relative humidity. Both friction and temperature at the time of testing shall be recorded and, if the tribosystem that is to be

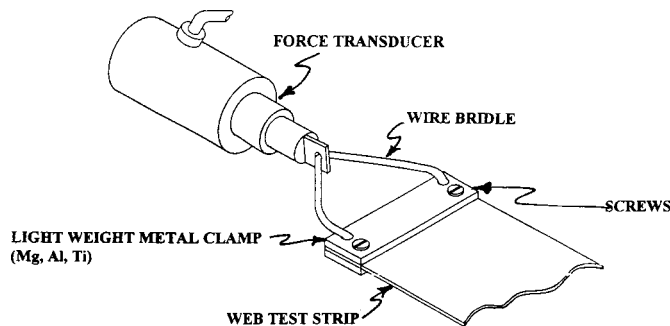

FIG. 3 Method for Gripping the Test Strip

simulated involves some special environment, then this should be simulated. Test samples should be incubated for an adequate time to reach equilibrium in the intended test environment prior to testing. Twenty four hours is a minimum incubation period.

**6.7 Calibration**—A suitable system for calibration of the force transducer is to mount the transducer vertically and simply apply a series of known weights on the transducer with the force recording device running. Make sure that the output of the force transducer is linearly proportional to the applied force over the range of forces to be measured. Calibrate using weights that produce force comparable in magnitude to the forces anticipated in the friction test.

## 7. Test Procedure

### 7.1 Specimen Preparation:

**7.1.1** Clean the roller surface in a manner that is consistent with the application that is under simulation. Cut virgin strips from the test web as the other friction member. Take care not to fingerprint or alter the test surface in handling the web. Convenient sample dimensions are 25 mm wide with a length of about 500 mm. Practice E 122 or other statistical methods can be used to determine the necessary number of test replicates. Three is the minimum.

**7.1.2** Do not clean the web specimen unless that is part of the study. If paper or plastic sheets are being tested, they should be tested with untouched as-manufactured surfaces. Cut the web specimen in such a fashion that there is no edge burr on the side that contacts the roller. This is extremely important. Ensure that the edges of the strip are parallel and in the desired orientation with respect to the long axis of the host web. A useful tool for sample preparation is to affix two single-edged razor blades to a block of wood spaced at the desired strip width. This device can be used to cut samples from thin plastic, cloth, and paper webs. The interlaboratory tests were conducted with web strips that were 25 mm in width and 500 mm long.

**7.2 Mounting the Specimen**—Affix one end of the web strip to the bridle end of the force transducer; drape the strip over the test roller (cylindrical surface), and apply the desired tensioning mass. Avoid clamp systems that have significant elasticity. If a tensile-testing machine is used to produce motion, flexible steel cable can be used to pull the strip. Ensure that the strip is pulled straight (aligned with the web tension) within  $\pm 1$  mm. Markers can be used on the test roller to determine if tracking is within the 1-mm limit.

### 7.3 Setting the Sliding Parameters :

**7.3.1 Velocity**—The capstan friction tester allows selection of sliding velocity, sliding distance, and free-end tension on the strip. It is recommended that values for these parameters be selected to simulate the system of interest. The sliding velocity between webs and transport or drive rollers in manufacturing machines is usually in the range from a fraction of a percent of the web speed to a worst case of 10 % of the web speed. (For example, if a web conveyance system is being simulated with a web speed of 1 m/s, a low-end test velocity may be 5 mm/s and the high-end test velocity 0.1 m/s.) There is a velocity limit in this type of test. High speed will cause instability in the contact of the web with the conforming cylindrical surface. Users can test the velocity limits of their system, but 0.1 m/s is about the limit of the systems that were used in interlaboratory testing. A continuous loop test (Test Method D 3108) is more appropriate for high sliding velocities.

**7.3.2 Sliding Distance**—If the goal of this test method is the static coefficient of friction, the test can be stopped after a few millimetres of sliding. If the goal of this test method is both the static and the kinetic coefficients of friction, it is desirable to slide for as long a distance as the test setup will allow. With the test setup shown in Fig. 1, the maximum travel on commercial linear motors is about 0.5 m. The allowable motion on the pulling device is the limiting factor on sliding distance. Interlaboratory tests were conducted with a sliding distance of 150 mm. This is the recommended sliding distance for this test.

**7.3.3 Test Tension**—The tensioning mass affixed to the free end of the strip specimen can be any magnitude that will simulate the system of interest. The practical limit is the mass that will produce tensile yielding or breaking of the test strip. The maximum tension that has been used in the ASTM interlaboratory tests was 150 N on a 25-mm wide test strip. Repeatability tests were conducted with a tension of 4.45 N on the 25 mm-wide test strip. It is advisable to test at a variety of web tensions if this is likely to be a variable in the tribosystem under study.

**7.4 Angle of Wrap**—The capstan formula that is used to calculate friction coefficients in this test method requires input of the angle of wrap of the test strip on the cylindrical surface. The most convenient test system uses a 90° wrap. Different degrees of wrap simply require another tensioning method than that shown in Fig. 1. The maximum angle of wrap possible with this test method is 180°. The use of 90° wrap is advised. This is what was used in interlaboratory testing.

**7.5 Conducting the Test**—Clean the roller as described in 7.1. Wearing cotton gloves and touching only the edges of the test strip, assemble the test strip into the holder affixed to the force measuring transducer; drape the test strip over the cylindrical surface; affix the tensioning mass to the free end of the strip. Initiate motion and force recording within 60 s after application of the tensioning mass (some materials will block if long residence times are used). Stop the motion after the desired sliding distance has been achieved. Record initial friction force and where kinetic friction coefficient is desired, record the friction force for the duration of the sliding cycle or at predetermined time intervals such as every 0.1 s.

**7.6 Record Test Observations**—The value of friction measurements is significantly enhanced by recording observations and events that happen in the test. Record your observations made during the test and also record visual conditions of the test specimens after the test. Did the couple squeal? Was there transfer of one material to the other? Is scratching evident? Did damage occur on the test surfaces? Surface features such as transferred material, scratches, and localized surface damage on one or both mating surfaces may be helpful in analyzing and understanding the significance of friction test results. See 3.1 for a definition of the word blocking as applied to plastics.