



Designation: F433-02 Designation: F 433 – 02 (Reapproved 2009)

Standard Practice for Evaluating Thermal Conductivity of Gasket Materials¹

This standard is issued under the fixed designation F 433; the number immediately following the designation indicates the year of original adoption or, in the case of revision, the year of last revision. A number in parentheses indicates the year of last reapproval. A superscript epsilon (ϵ) indicates an editorial change since the last revision or reapproval.

1. Scope

- 1.1 This practice covers a means of measuring the amount of heat transfer quantitatively through a material or system.
- 1.2 This practice is similar to the Heat Flow Meter System of Test Method C 518, but modified to accommodate small test samples of higher thermal conductance.
- 1.3 The values stated in SI units are to be regarded as the standard. The values given in parentheses are for information only.
- 1.4 *This standard does not purport to address all of the safety concerns, if any, associated with its use. It is the responsibility of the user of this standard to establish appropriate safety and health practices and determine the applicability of regulatory limitations prior to use.*

2. Referenced Documents

- 2.1 *ASTM Standards:*²
 - C 518 [Test Method for Steady-State Thermal Transmission Properties by Means of the Heat Flow Meter Apparatus](#)
 - D 2214 [Test Method for Estimating the Thermal Conductivity of Leather with the Cenco-Fitch Apparatus](#)
 - F 104 [Classification System for Nonmetallic Gasket Materials](#)

3. Terminology

3.1 Definitions:

3.1.1 *thermal conductivity, k , of a solid material*—the time rate of steady heat flow, watts (or Btu/h), through a unit area, m^2 (or ft^2), per unit temperature gradient in the direction perpendicular to an isothermal surface $^{\circ}C/m$ (or $^{\circ}F/in.$). The k -factor is expressed $W/m \cdot K$ ($Btu \cdot in./h \cdot ft^2 \cdot ^{\circ}F$).

3.2 Symbols:

k	= thermal conductivity, $W/m \cdot K$ ($Btu \cdot in./h \cdot ft^2 \cdot ^{\circ}F$)
C	= thermal conductance, $W/m^2 \cdot K$ ($Btu/h \cdot ft^2 \cdot ^{\circ}F$)
Δx	= sample thickness, mm (in.)
A	= sample cross-sectional area, m^2 (ft^2)
q	= heat flow, W (Btu/h)
ϕ	= heat flow transducer output, mV
N	= heat flow transducer calibration constant, $W/m^2 \cdot mV$ ($Btu/h \cdot ft^2 \cdot mV$)
$N\phi$	= heat flux, W/m^2 ($Btu/h \cdot ft^2$)
ΔT	= temperature difference, $^{\circ}C$ ($^{\circ}F$) or mV
T_1	= temperature of lower sample surface, $^{\circ}C$ ($^{\circ}F$) or mV
T_2	= temperature of upper sample surface, $^{\circ}C$ ($^{\circ}F$) or mV
T_h	= temperature of HFT surface facing sample, $^{\circ}C$ ($^{\circ}F$) or mV
T_c	= temperature of upper heater surface facing sample, $^{\circ}C$ ($^{\circ}F$) or mV
T	= temperature, $^{\circ}C$ ($^{\circ}F$)
δ	= total temperature drop across interfaces between sample and adjacent surfaces, $^{\circ}C$ ($^{\circ}F$) or mV
ρ	= coefficient of thermal resistance at interfaces, $m^2 \cdot K/W$ ($h \cdot ft^2 \cdot ^{\circ}F/Btu$)
α	= correction constant
subscript s	= unknown sample

¹ This practice is under the jurisdiction of ASTM Committee F03 on Gaskets and is the direct responsibility of Subcommittee F03.10 on Composite Gaskets. Current edition approved October 10, 2002. Published October 2002.

Current edition approved May 1, 2009. Published May 2009. Originally approved in 1964. Last previous edition approved in 2002 as F 433 – 02.

² For referenced ASTM standards, visit the ASTM website, www.astm.org, or contact ASTM Customer Service at service@astm.org. For *Annual Book of ASTM Standards* volume information, refer to the standard's Document Summary page on the ASTM website.

subscript r = known calibration sample

4. Summary of Practice

4.1 The sample and the heat flow transducer (HFT) are sandwiched between two controlled heater plates. The lower heater is set at a higher temperature than the upper plate to produce a flow of heat through the sample. The differential of these two temperatures, ΔT , sensed by thermocouples, is amplified along with the electrical output, ϕ , of the HFT and is directly proportional to the heat flow through the sample, expressed as W/m^2 (Btu/h-ft²). See Appendix for further information. This recommended practice can be used for measuring heat transfer at a hot side temperature up to 200°C (392°F). See Figs. 1-5.

5. Significance and Use

5.1 This practice is designed to compare related materials under controlled conditions and their ability to maintain a minimum amount of thermal conductance. Test results should be correlated with field results in order to predict heat transfer properties in particular applications.

5.2 This practice may be used as a routine test when agreed upon by the user and the producer.

6. Apparatus

6.1 Heat Flow Transducer (HFT), with controlled heater plates, thermocouples, and an analog computer module.³

7. Test Specimen

7.1 The sample size shall be a 50.8-mm (2-in.) diameter disk ± 0.25 mm (± 0.010 in.) from 2.29 to 12.7 mm (0.090 to 0.500 in.) thick.

8. Conditioning

8.1 Condition the cut specimens in accordance with their classification, as required in Classification F 104.

9. Procedure

9.1 Test temperatures are suggested from 100 to 175°C (212 to 347°F) or whatever is agreed upon between the producer and user. (The guard heater is usually set at or near the average sample temperature between the lower and upper heater plates.)

9.1.1 Release the compressive load, pull out the tray, and load the sample. Care must be maintained to ensure that the tray compartment is free of any foreign matter. Clean as required.

9.1.2 Push the tray back into the chamber with a ball and plunger locking the tray into position.

iTech Standards
ASTM F433-02(2009)
Document Preview

ASTM F433-02(2009)

³Annual Book of ASTM Standards, Vol 15.04. [standards/sist/87f7cf2d-9b40-4368-9ca8-adb9680bd0a3/astm-f433-022009](http://standards.sist/87f7cf2d-9b40-4368-9ca8-adb9680bd0a3/astm-f433-022009)

³The sole source of supply of the apparatus known to the committee at this time is Holometrix, Inc., 25 Wiggins Avenue, Bedford, MA 01730-2323. If you are aware of alternative suppliers, please provide this information to ASTM Headquarters. Your comments will receive careful consideration at a meeting of the responsible technical committee, which you may attend.

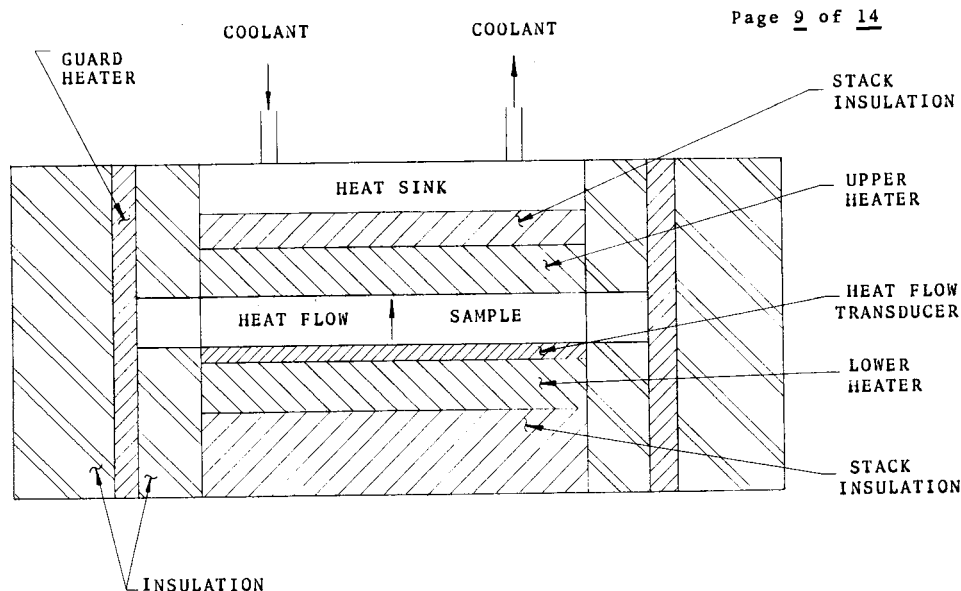

FIG. 1 Heat Flow Meter Assembly With Water-Cooled Heat Sink

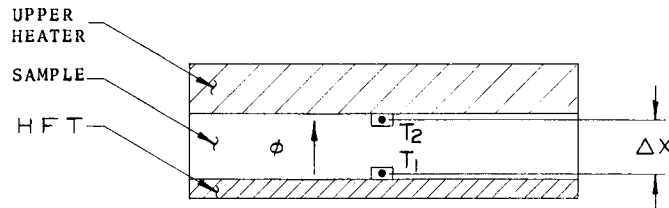

FIG. 2 HFT Electrical Output and Heat Flow Section With Temperature Sensors

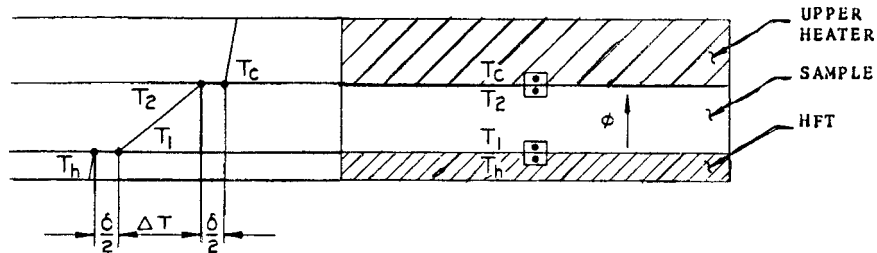

FIG. 3 Location of Thermocouples to Produce a Temperature Gradient Through the Test Sample

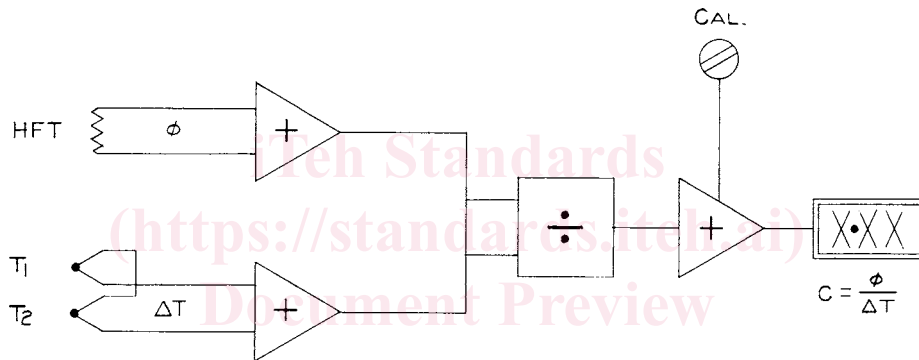

FIG. 4 The Hot and Cold Sample Surface Temperature Differential Amplified with the HFT Output, Divided Electronically, and Displayed Digitally

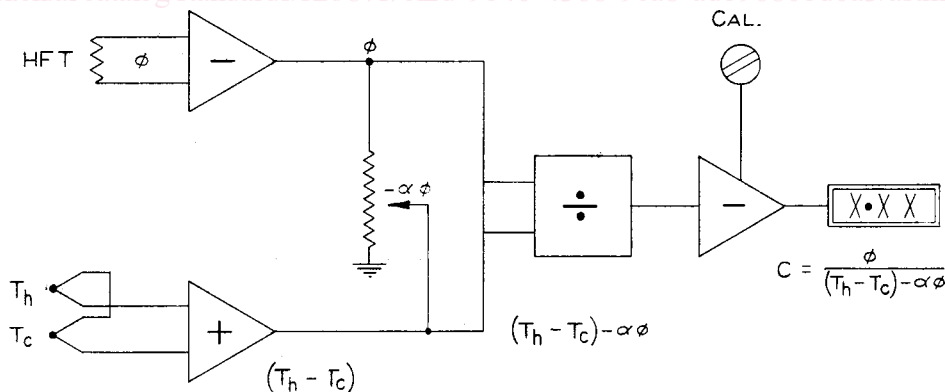

FIG. 5 Clarification of Fig. 4 Showing the Calibration to Obtain the Correction Constant Correct Value Before Testing an Unknown Sample

9.1.3 Close the test section door and switch the air control to “stack clamped.” The sample holder is now raised automatically until the sample is clamped in place between the upper and lower heaters. The compressive load can be adjusted by controlling the air pressure at the rear of the unit. A pressure of 0.345 MPa (50 psi) is the recommended maximum and should be specified by both the producer and user to ensure repeatable results.

9.1.4 Allow from 1 to 2 h for the reading to stabilize. Read the sample thermal conductance and temperature directly from digital meters on the front panel. The instrument has stabilized when the temperature indicated changes by no more than $\pm 5\%/h$ and the conductance indicated changes no more than $\pm 2\%/h$.

10. Report

10.1 The report shall include the following:

10.1.1 Sample conditioning procedure,

10.1.2 Ambient temperature,

10.1.3 Sample hot side temperature, T_h ,

10.1.4 Sample cold side temperature, T_c ,

10.1.5 Sample temperature drop, $T_h - T_c$,

10.1.6 Average sample temperature, $(T_h + T_c)/2$,

10.1.7 Sample thickness, Δx ,

10.1.8 Thermal conductivity, k , and

10.1.9 Compressive load.

iTeh Standards
(<https://standards.iteh.ai>)
Document Preview

[ASTM F433-02\(2009\)](#)

<https://standards.iteh.ai/catalog/standards/sist/87f7cf2d-9b40-4368-9ca8-adb9680bd0a3/astm-f433-022009>