



# SLOVENSKI STANDARD

## oSIST prEN 1273:2019

01-april-2019

---

### Izdelki za otroke - Hojce - Varnostne zahteve in preskusne metode

Child use and care articles - Baby walking frames - Safety requirements and test methods

Artikel für Säuglinge und Kleinkinder - Kinderlaufhilfen - Sicherheitstechnische Anforderungen und Prüfverfahren

Articles de puériculture - Trotteurs - Exigences de sécurité et méthodes d'essai

iTeh STANDARD PREVIEW  
(standards.iteh.ai)

Ta slovenski standard je istoveten z: <sup>SIST EN 1273:2021</sup> prEN 1273  
<https://standards.iteh.ai/catalog/standards/sist/52f4d6a-221f-4e50-85dc-6b8436ac880c/sist-en-1273-2021>

---

#### ICS:

97.190      Otroška oprema      Equipment for children

**oSIST prEN 1273:2019**

**en,fr,de**

**iTeh STANDARD PREVIEW**  
**(standards.iteh.ai)**

SIST EN 1273:2021

<https://standards.iteh.ai/catalog/standards/sist/52fffd6a-221f-4e50-85dc-6b8436ac880c/sist-en-1273-2021>

EUROPEAN STANDARD  
NORME EUROPÉENNE  
EUROPÄISCHE NORM

**DRAFT**  
**prEN 1273**

March 2019

ICS 97.190

Will supersede EN 1273:2005

English Version

## Child use and care articles - Baby walking frames - Safety requirements and test methods

Articles de puériculture - Trotteurs - Exigences de sécurité et méthodes d'essai

Artikel für Säuglinge und Kleinkinder - Kinderlaufhilfen - Sicherheitstechnische Anforderungen und Prüfverfahren

This draft European Standard is submitted to CEN members for enquiry. It has been drawn up by the Technical Committee CEN/TC 252.

If this draft becomes a European Standard, CEN members are bound to comply with the CEN/CENELEC Internal Regulations which stipulate the conditions for giving this European Standard the status of a national standard without any alteration.

This draft European Standard was established by CEN in three official versions (English, French, German). A version in any other language made by translation under the responsibility of a CEN member into its own language and notified to the CEN-CENELEC Management Centre has the same status as the official versions.

CEN members are the national standards bodies of Austria, Belgium, Bulgaria, Croatia, Cyprus, Czech Republic, Denmark, Estonia, Finland, Former Yugoslav Republic of Macedonia, France, Germany, Greece, Hungary, Iceland, Ireland, Italy, Latvia, Lithuania, Luxembourg, Malta, Netherlands, Norway, Poland, Portugal, Romania, Serbia, Slovakia, Slovenia, Spain, Sweden, Switzerland, Turkey and United Kingdom.

Recipients of this draft are invited to submit, with their comments, notification of any relevant patent rights of which they are aware and to provide supporting documentation.

**Warning** : This document is not a European Standard. It is distributed for review and comments. It is subject to change without notice and shall not be referred to as a European Standard.



EUROPEAN COMMITTEE FOR STANDARDIZATION  
COMITÉ EUROPÉEN DE NORMALISATION  
EUROPÄISCHES KOMITEE FÜR NORMUNG

**CEN-CENELEC Management Centre: Rue de la Science 23, B-1040 Brussels**

<b>Contents</b>	<b>Page</b>
<b>European foreword</b> .....	<b>3</b>
<b>Introduction</b> .....	<b>4</b>
<b>1 Scope</b> .....	<b>5</b>
<b>2 Normative references</b> .....	<b>5</b>
<b>3 Terms and definitions</b> .....	<b>5</b>
<b>4 Test equipment</b> .....	<b>6</b>
<b>5 General requirements and test conditions</b> .....	<b>12</b>
<b>6 Chemical hazards (see A.2)</b> .....	<b>12</b>
<b>7 Thermal hazards (see A.3)</b> .....	<b>14</b>
<b>8 Mechanical hazards (see A.4)</b> .....	<b>15</b>
<b>9 Product information</b> .....	<b>29</b>
<b>Annex A (informative) Rationales</b> .....	<b>32</b>
<b>A.1 Introduction</b> .....	<b>32</b>
<b>A.2 Chemical hazards (see Clause 6)</b> .....	<b>32</b>
<b>A.3 Thermal hazards (see Clause 7)</b> .....	<b>32</b>
<b>A.4 Mechanical hazards (see Clause 8)</b> .....	<b>32</b>
<b>Annex B (normative) Test platform for tip over test</b> .....	<b>34</b>
<b>Annex C (normative) Warnings</b> .....	<b>35</b>
<b>Annex D (informative) A-Deviation</b> .....	<b>36</b>
<b>Bibliography</b> .....	<b>37</b>

## European foreword

This document (prEN 1273:2019) has been prepared by Technical Committee CEN/TC 252 “Child care articles”, the secretariat of which is held by AFNOR.

This document is currently submitted to the CEN Enquiry.

This document will supersede EN 1273:2005.

In comparison with the previous edition EN 1273:2005, the following major technical modifications have been made:

- general redraft in hazard based format;
- addition of new chemical requirements based on CEN/TR 13387-2;
- general update of some mechanical requirements and test methods to the state of the art of CEN/TR 13387-3;
- improvement of the requirements and test methods for static and dynamic strength;
- modification of the test method for prevention of falls down stairs to improve reproducibility of results;
- update of product information section and addition of a new symbol from CEN/TR 13387-5.

**iTeh STANDARD PREVIEW**  
**(standards.iteh.ai)**

SIST EN 1273:2021

<https://standards.iteh.ai/catalog/standards/sist/52fffd6a-221f-4e50-85dc-6b8436ac880c/sist-en-1273-2021>

## Introduction

The purpose of this European Standard is to reduce the risk of accidents.

It is stressed that this European Standard cannot eliminate all possible risks to children using such a product and that carer control is of paramount importance. Accidents are mainly due to carer(s) not anticipating the extra reach and speed that children can achieve in the baby walking frame.

It is essential that all warnings and instructions specified in this standard are clearly given by the manufacturer, to ensure that the baby walking frame can be used safely and correctly.

## iTeh STANDARD PREVIEW (standards.iteh.ai)

SIST EN 1273:2021

<https://standards.iteh.ai/catalog/standards/sist/52fffd6a-221f-4e50-85dc-6b8436ac880c/sist-en-1273-2021>

## 1 Scope

This document specifies safety requirements and test methods for baby walking frames into which a child is placed, and intended to be used from when the child is able to sit up by itself until the child is able to walk by itself.

This document does not apply to baby walking frames for therapeutic and curative purposes and to those baby walking frames relying on inflatable parts to support the child.

Toys (e.g. ride on toys, push-along toys, usually intended for children able to walk unaided) are not covered by this document.

If a baby walking frame has several functions or can be converted into another function the relevant European standards apply to it.

## 2 Normative references

The following documents are referred to in the text in such a way that some or all of their content constitutes requirements of this document. For dated references, only the edition cited applies. For undated references, the latest edition of the referenced document (including any amendments) applies.

EN 71-2:2011+A1:2014, *Safety of toys — Part 2: Flammability*

EN 71-3, *Safety of toys — Part 3: Migration of certain elements*

EN 71-10:2005, *Safety of toys — Part 10: Organic chemical compounds — Sample preparation and extraction*

EN 71-11, *Safety of toys — Part 11: Organic chemical compounds — Methods of analysis*

EN 622-1, *Fibreboards — Specifications — Part 1: General requirements*

EN 717-1, *Wood-based panels — Determination of formaldehyde release — Part 1: Formaldehyde emission by the chamber method*

EN ISO 14184-1, *Textiles — Determination of formaldehyde — Part 1: Free and hydrolysed formaldehyde (water extraction method) (ISO 14184-1:2011)*

EN ISO 14362-1, *Textiles — Methods for determination of certain aromatic amines derived from azo colorants — Part 1: Detection of the use of certain azo colorants accessible with and without extracting the fibres (ISO 14362-1:2017)*

EN ISO 17234-1, *Leather — Chemical tests for the determination of certain azo colorants in dyed leathers — Part 1: Determination of certain aromatic amines derived from azo colorants (ISO 17234-1:2015)*

ISO 2813, *Paints and varnishes — Determination of gloss value at 20 degrees, 60 degrees and 85 degrees*

## 3 Terms and definitions

For the purposes of this document, the following terms and definitions apply.

ISO and IEC maintain terminological databases for use in standardization at the following addresses:

- IEC Electropedia: available at <http://www.electropedia.org/>
- ISO Online browsing platform: available at <http://www.iso.org/obp>

**prEN 1273:2018 Rev (E)****3.1****baby walking frame**

structure with a seat in which a child is placed in a sitting or standing position, which allows a child to move around with the aid of the support offered by the frame

**3.2****crotch strap**

device which passes between the child's legs to prevent the child slipping out of the seat

**3.3****base**

lower part of the frame where castors or wheels may be attached

**3.4****parking device**

device to maintain the baby walking frame in a stationary position

**4 Test equipment****4.1 Test masses****4.1.1 Test mass A**

Test mass A is a rigid cylinder (160 ± 5) mm in diameter and (280 ± 5) mm in height, having a mass of  $12_0^{+0,1}$  kg and with its centre of gravity in the centre of the cylinder. All edges shall have a radius of (20 ± 1) mm.

**4.1.2 Test mass B**

Test mass B is a rigid cylinder (160 ± 5) mm in diameter and (280 ± 5) mm in height, having a mass of  $7,65_0^{+0,1}$  kg and with its centre of gravity in the centre of the cylinder. All edges shall have a radius of (20 ± 1) mm.

**4.1.3 Test mass C**

Test mass C is a rigid cylinder (160 ± 5) mm in diameter and (280 ± 5) mm in height, having a mass of  $12,6_0^{+0,1}$  kg and with its centre of gravity in the centre of the cylinder. All edges shall have a radius of (20 ± 1) mm.

**4.1.4 Test mass D**

Test mass D is a mass of 3,6 kg with a flat circular bottom surface.

**4.2 Small parts cylinder**

Small parts cylinder for the assessment of small components, having dimensions in accordance with Figure 1.



Dimension in millimetres

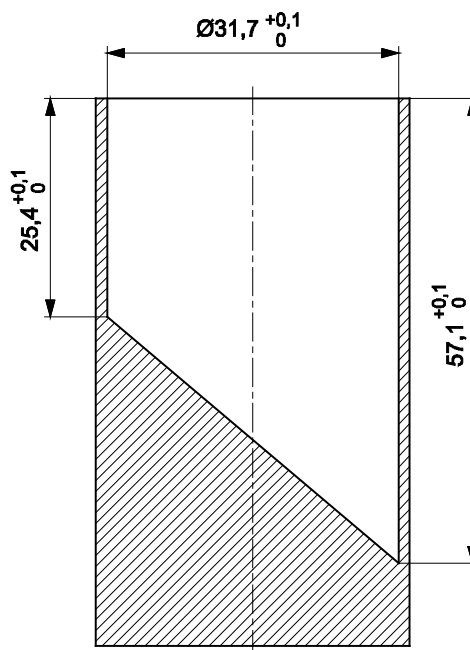

Figure 1 — Small parts cylinder

iTeh STANDARD PREVIEW  
(standards.iteh.ai)

### 4.3 Feeler gauge

Gauge with a thickness of  $(0,4 \pm 0,02)$  mm and an insertion edge radius of  $(3 \pm 0,5)$  mm (see Figure 2).

SIST EN 1273:2021

<https://standards.iteh.ai/catalog/standards/sist/52fffd6a-221f-4e50-85dc-6b8436ac880c/sist-en-1273-2021>

Dimensions in millimetres

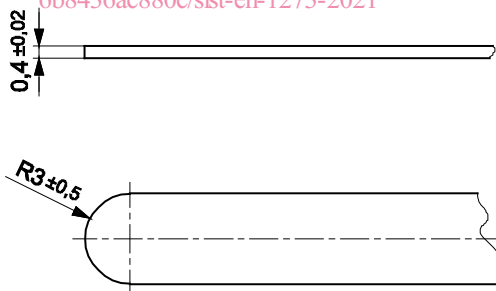

Figure 2 — Feeler gauge

### 4.4 Test probes for finger entrapment

#### 4.4.1 Test probes with hemispherical end

Probes made from plastic or other hard, smooth material of diameters  $7_{-0,1}^0$  mm and  $12_{-0,1}^{+0,1}$  mm with a full hemispherical end that can be mounted on a force-measuring device, see Figure 3.

Mesh probe made from plastic or other hard, smooth material as shown in Figure 4.

Dimensions in millimetres

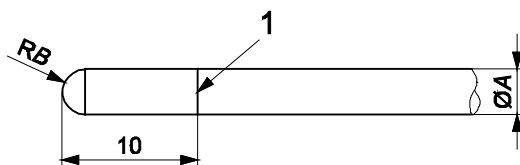

**Key**

Probe type	7 mm probe	12 mm probe
Diameter A	$7_{-0,1}^0$	$12_{0}^{+0,1}$
Radius RB	half of diameter A	half of diameter A

1 Line scribed around circumference showing depth of penetration

**Figure 3 — Test probes with hemispherical end**

Dimensions in millimetres

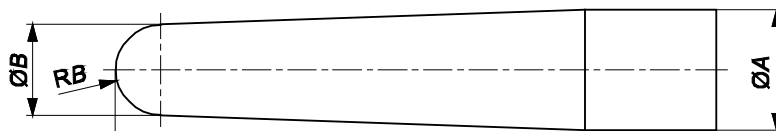

iTeh STANDARD PREVIEW  
(standards.iteh.ai)

**Key**

Probe type	Mesh probe
Diameter A	$7_{-0,1}^0$ <a href="https://standards.iteh.ai/catalog/standards/sist/52fffd6a-221f-4e50-85dc-6b8436ac880c/sist-en-1273-2021">SIST EN 1273:2021</a>
Diameter B	$5,6_{-0,1}^0$ <a href="https://standards.iteh.ai/catalog/standards/sist/52fffd6a-221f-4e50-85dc-6b8436ac880c/sist-en-1273-2021">https://standards.iteh.ai/catalog/standards/sist/52fffd6a-221f-4e50-85dc-6b8436ac880c/sist-en-1273-2021</a>
Radius RB	half of diameter B

**Figure 4 — Test probe for mesh**

**4.4.2 Shape assessment probe**

Probe made from plastics or other hard, smooth material with the dimensions shown in Figure 5.

Dimensions in millimetres

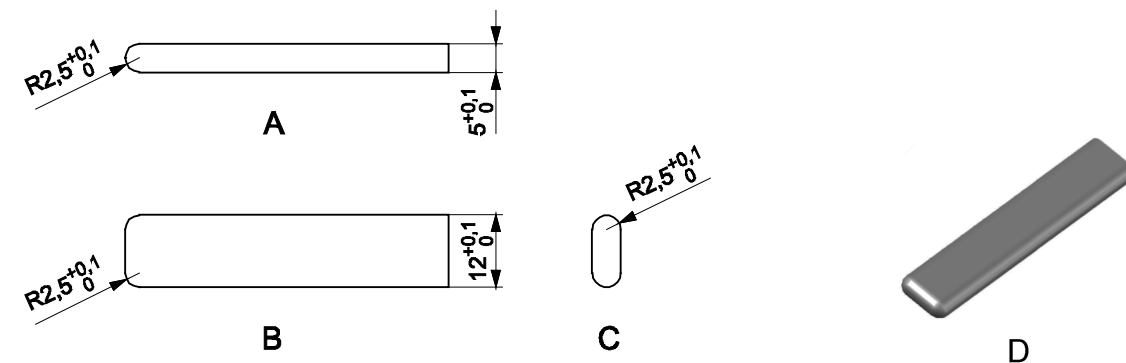
**Key**

- A front view
- B top view
- C side view
- D 3D view

**Figure 5 — Shape assessment probe****4.5 Test platform for stability test**

A sloping platform inclined at an angle of  $30^\circ$  to the horizontal with a 100 mm stop fitted to the lower edge of the slope (Figure 6).

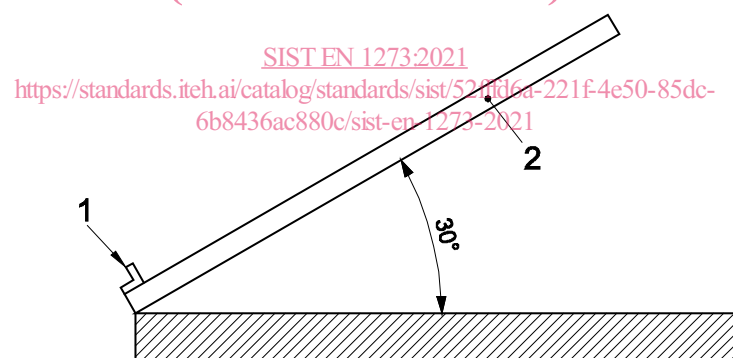
**Key**

- 1 stop
- 2 platform

**Figure 6— Static stability test****4.6 Test equipment for dynamic stability****4.6.1 Test platform**

The test platform of 4.7.1 with an aluminium stop with a height of 40 mm and thickness of at least 10 mm at its front edge.

**4.6.2 Spacer**

A squared sectioned piece of aluminium 40 mm by 40 mm with a minimum length of 200 mm.

## 4.7 Test equipment for prevention of fall down steps test

### 4.7.1 Test platform

A horizontal test platform as shown in Figure B.1 with a flat smooth surface made of beech wood with a minimum thickness of 18 mm.

The front edge shall be straight cut, without any radius (Figure 7).

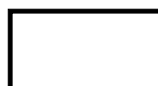
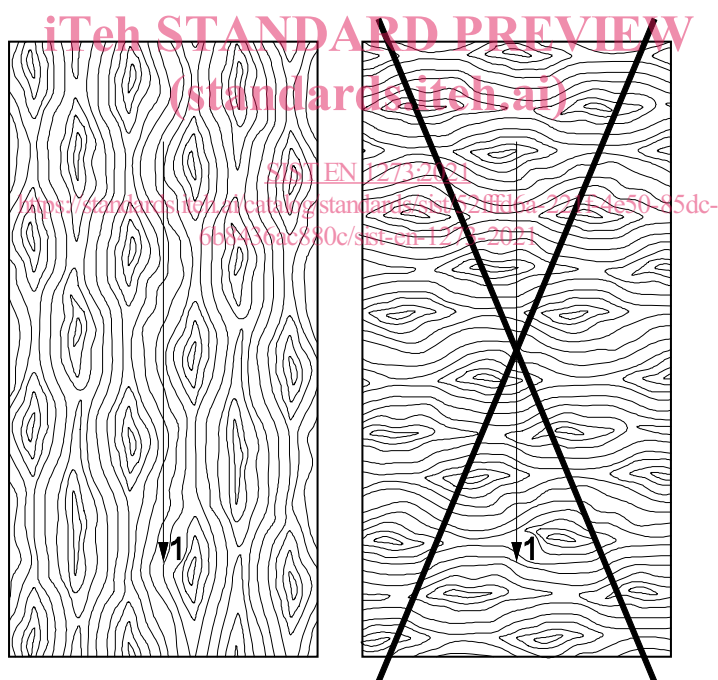

**Figure 7 — Front edge of the test platform**

The grain of the wooden surface shall be orientated in line with the longitudinal axis of the test platform and there shall be no joints perpendicular to the longitudinal axis of the test platform (see Figure 8).

The top shall be pre-finished with wood floor polyurethane varnish with a nominal gloss of  $(75 \pm 5)$  gloss units measured with an angle of  $60^\circ$  according to ISO 2813.

The wooden surface shall be fixed to the frame to avoid deformation of the wooden surface during the tests. If variations in temperature and/or humidity in the laboratory cause the wooden surface to deform, the fixing shall be adjusted to ensure the wooden surface is flat.



#### Key

- 1 direction of the baby walking frame movement

**Figure 8 — Orientation of the wooden surface**

### 4.7.2 Steel cable

A galvanised steel cable with a nominal diameter of  $2 \text{ mm} \pm 0,1 \text{ mm}$ .