



Standard Test Method for Evaporation Loss of Lubricating Oils by the Noack Method¹

This standard is issued under the fixed designation D 5800; the number immediately following the designation indicates the year of original adoption or, in the case of revision, the year of last revision. A number in parentheses indicates the year of last reapproval. A superscript epsilon (ϵ) indicates an editorial change since the last revision or reapproval.

^{ε1} NOTE—Section 33 (Repeatability and Reproducibility) equations were corrected editorially in November 2001.

1. Scope

1.1 This test method covers three procedures for determining the evaporation loss of lubricating oils (particularly engine oils). Procedure A uses the Noack evaporative tester equipment; Procedure B uses the automated non-Wood's metal Noack evaporative apparatus, and Procedure C uses Selby-Noack volatility test equipment. The test method relates to one set of operating conditions but may be readily adapted to other conditions when required.

1.2 The values stated in SI units are to be regarded as the standard. The values given in parentheses are for information only.

1.3 *This standard does not purport to address all of the safety concerns, if any, associated with its use. It is the responsibility of the user of this standard to establish appropriate safety and health practices and determine the applicability of regulatory limitations prior to use.* See Sections 8 and 18 and 6.1.1, 7.1, 7.5, 9.1, 10.3, and 17.1 for specific precautionary statements.

2. Referenced Documents

2.1 ASTM Standards:

D 4057 Practice for Manual Sampling of Petroleum and Petroleum Products²

D 4177 Practice for Automatic Sampling of Petroleum and Petroleum Products²

D 6299 Practice for Applying Statistical Quality Assurance Techniques to Evaluate Analytical Measurement System Performance³

D 6300 Practice for Determination of Precision and Bias Data for Use in Test Methods for Petroleum Products and Lubricants³

2.2 DIN Standards:⁴

DIN 1725 Specification for Aluminum Alloys

DIN 12785 Specifications for Glass Thermometers

3. Terminology

3.1 Definitions of Terms Specific to This Standard:

3.1.1 *evaporation loss*—of a lubricating oil by the Noack method, that mass of volatile oil vapors lost when the oil is heated in a test crucible through which a constant flow of air is drawn.

3.1.2 *volatility, n*—the tendency of a liquid to form a vapor.

4. Summary of Test Method

4.1 A measured quantity of sample is placed in an evaporation crucible or reaction flask that is then heated to 250°C with a constant flow of air drawn through it for 60 min. The loss in mass of the oil is determined.

4.2 Interlaboratory tests have shown that Procedure A, Procedure B, and Procedure C yield essentially equivalent results, with a correlation coefficient of R squared = 0.996. See research report RR:D02-1462 for the Selby-Noack interlaboratory study.

5. Significance and Use

5.1 The evaporation loss is of particular importance in engine lubrication. Where high temperatures occur, portions of an oil can evaporate.

5.2 Evaporation may contribute to oil consumption in an engine and can lead to a change in the properties of an oil.

5.3 Many engine manufacturers specify a maximum allowable evaporation loss.

5.4 Some engine manufacturers, when specifying a maximum allowable evaporation loss, quote this test method along with the specifications.

5.5 Procedure C, using the Selby-Noack apparatus, also permits collection of the volatile oil vapors for determination of their physical and chemical properties. Elemental analysis of the collected volatiles may be helpful in identifying components such as phosphorous, which has been linked to premature degradation of the emission system catalyst.

Procedure A

6. Apparatus

6.1 *Noack Evaporative Tester*, comprising the following:

¹ This test method is under the jurisdiction of ASTM Committee D02 on Petroleum Products and Lubricants and is the direct responsibility of Subcommittee D02.06 on Analysis of Lubricants.

Current edition approved Aug. 10, 2000. Published October 2000. Originally published as D 5800 – 95. Last previous edition D 5800 – 00.

² *Annual Book of ASTM Standards*, Vol 05.02.

³ *Annual Book of ASTM Standards*, Vol 05.03.

⁴ Available from Deutsches Institut für Normung, Beuth Verlag GmbH, Burggraf-Strasse 6, 1000 Berlin 30, Germany.

6.1.1 *Electrically Heated Block Unit*, made from a malleable aluminum alloy (see DIN 1725, Sheet 1), insulated at the jacket and base against loss of heat. (**Warning**—This block is heated to 250°C.) The block is heated electrically by a base and jacket heater, having a total power consumption of 1 to 1.2 kW. In this respect the difference between both individual power consumption should not exceed 0.15 kW. In the center of the heating block, there is a circular recess to insert the evaporating crucible, the space between block and crucible being filled with Woods alloy or a suitable equivalent. Two catches on the block prevent the crucible from rising in the liquid metal bath. Two additional circular recesses at equal intervals from the center of the block are provided for the thermometers (see Fig. 1).

6.1.2 *Evaporating Crucible*, with screw cover. The crucible is made of stainless steel (see Fig. 2). Above the support ring is the thread for the cover. The nickel-plated brass cover is hermetically sealed to the crucible by an internal conical sealing surface (see Fig. 3). Three nozzles of hardened steel permit the air stream to pass through the cover. The extraction tube, which slopes downward, leads from a threaded and sealed connection in the center of the cover.

6.2 *Balance*, capable of weighing at least 200 g to the nearest 0.01 g.

6.3 *Crucible Clamp and Spanner*.

6.4 *Reamer*, 2-mm diameter.

6.5 *Ball Bearing*, 3.5-mm diameter.

6.6 *Thermometer*, M260 (see DIN 12785) or temperature sensing device capable of reading temperature to 0.1°C. The thermometer should be calibrated with appropriate procedure at appropriate frequency (generally every six months).

6.7 *Contact Type Control Thermometer* (for manual).

6.8 *Glass Y-piece*, an internal diameter of 4 mm. The upright arms, each 45-mm long, should form an angle such that the arm connected to the crucible extraction tube and the Y-piece form a straight line. The vertical arm is 60-mm long and beveled at 45°.

6.9 *Glass Delivery Tubes*, an internal diameter of 4 mm, each arm length 100 mm, beveled at 45° at ends entering and leaving the bottles.

6.9.1 Bent at an angle of approximately 80°.

6.9.2 Bent at an angle of approximately 100°, length to 20 mm of bottle base.

6.9.3 Bent at an angle of approximately 90°.

6.10 *Two Glass Bottles*, approximately 2-L capacity, fitted with rubber bungs bored to receive inlet and outlet tubes (see Fig. 4).

6.11 *Manometer*, inclined form, water-filled, precision 0.2 mm H₂O or suitable pressure sensor capable of measuring 20 ± 0.2 mm of H₂O (a 0 to 50-mm H₂O pressure transducer has been found to be satisfactory).

NOTE 1—Some manometers use water as the reference fluid, others may use a lower density fluid correlated to read in millimetres of water. Users should ensure that the manometer is filled with the correct density reference fluid.

6.12 *Glass T-Piece*, with bleed valve attached.

6.13 *Vacuum Pump*.

6.14 *Timer*, with accuracy of 0.2 s.

6.15 *Silicone Rubber Tubing*, cut to size, with an internal diameter of 4 mm.

6.15.1 40-mm long; three pieces required,

6.15.2 300-mm long, and

6.15.3 100-mm long.

NOTE 2—The use of automated equipment is permissible as long as it gives equivalent results specified in this test method. All hardware dimensions, make-up of the block, crucible, heat capacity, and so forth, and glassware must conform to the specifications given in this test method.

7. Reagents and Materials

7.1 *Cleaning Solvent*—A mixture of naphtha and toluene is recommended for the cleaning of the crucible. (**Warning**—Flammable, vapor harmful.) Overnight soaking may be necessary.

7.2 *Datum Oil RL 172*, (formerly RL-N) Reference Oil.

7.3 *Insulated Gloves*.

7.4 *Paint Brush*, such as a tinnerps acid brush (15 to 25-mm width).

7.5 *Woods Metal⁵ or suitable heat transfer material*—(**Warning**—Woods metal contains lead (25 %), bismuth (50 %), antimony (12.5 %), and cadmium (12.5 %); these have been found to be health hazardous. Avoid contact with skin at all times.)

8. Hazards

8.1 *Safety Hazards*—It is assumed that anyone using this test method will either be fully trained and familiar with all normal laboratory practices, or will be under the direct supervision of such a person. It is the responsibility of the operator to ensure that all local legislative and statutory requirements are met.

8.2 **Warning**—Though the test method calls for a draft free area, the exhaust fumes from the evaporating oil must be ventilated to an outside source. Precaution shall be taken to avoid any possibility of fire or explosion.

9. Preparation of Apparatus

9.1 A standard assembly of the apparatus is shown in Fig. 5. To avoid disturbing the thermal equilibrium, the apparatus shall be assembled in a draft free area and comply with Fig. 5 in dimensions and apparatus. (**Warning**—see 8.2.)

9.2 Add sufficient Woods metal or equivalent material to the recesses of the heating block so that, with the crucible and thermometer in place, the remaining spaces will be filled with the molten metal.

9.3 Using the highest heating rate possible, raise the temperature of the heating block until the Woods metal is molten. Insert the thermometers with their bulbs touching the bottom of the recesses, and ensure that the contact thermometer is plugged in the back of the heating block. Adjust the power supplied to the heating block so that the temperature can be maintained at 250 ± 0.5°C.

⁵ Woods metal, available from Aldrich Chemical Co., has been found satisfactory for this purpose. An equivalent may be used. Subcommittee D02.06 is evaluating less toxic alloys as alternatives.

ASTM D 5800 – 00a^{e1}

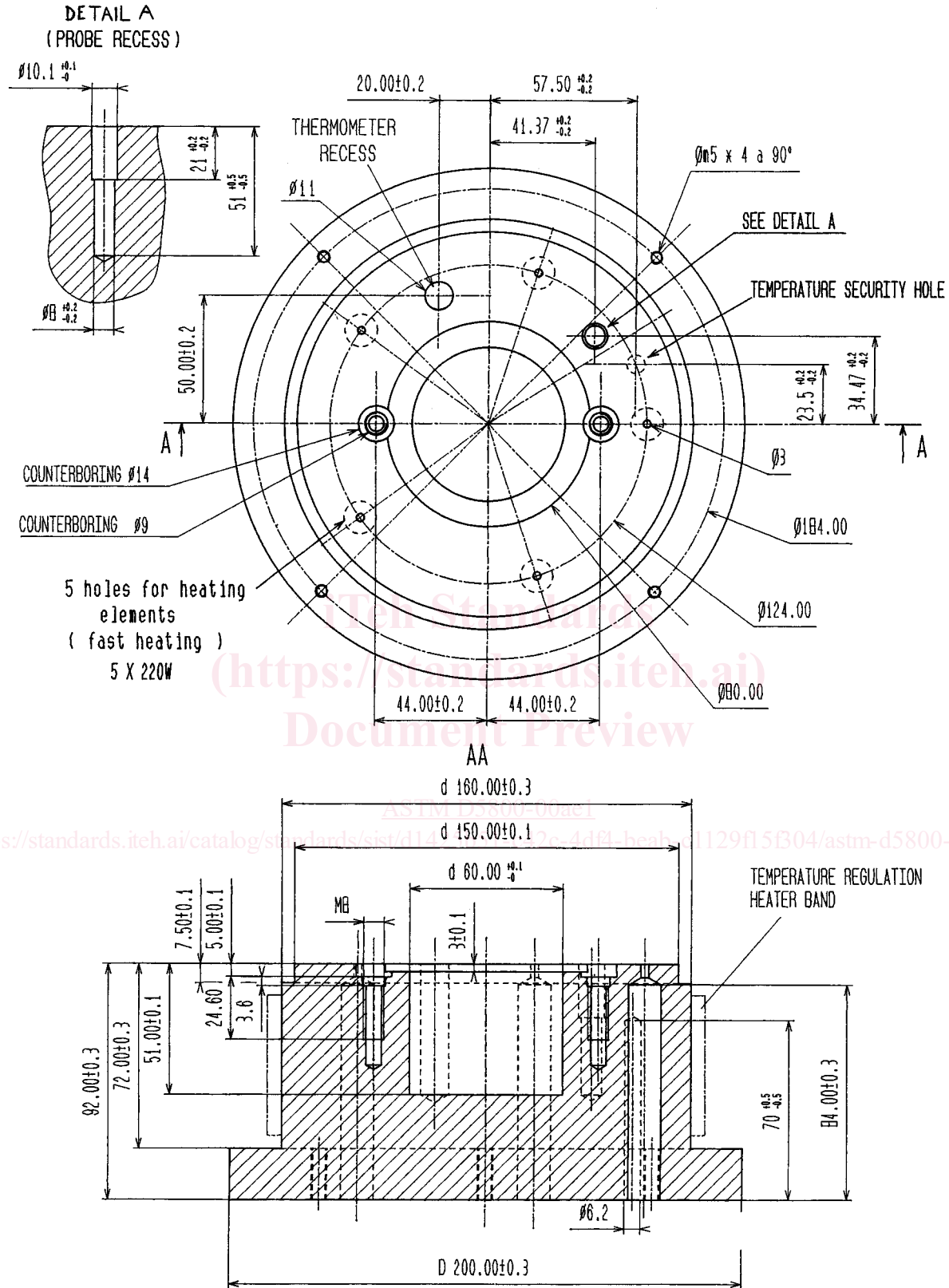

NOTE 1—All dimensions in millimetres.

FIG. 1 Heating Block

ASTM D 5800 – 00a^{e1}

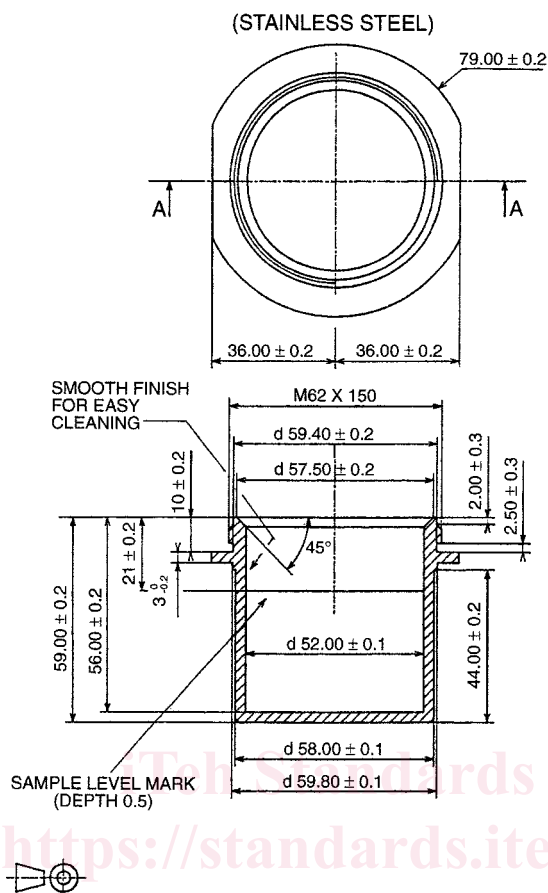

NOTE 1—All dimensions in millilitres.

FIG. 2 Crucible

9.4 Assemble the remaining apparatus, less the crucible, as shown in Fig. 5.

9.5 Place an empty crucible in the heating block, securing the flange under the screw heads against the buoyancy of the Woods metal. The level of the molten metal should be such that a trace of it can be seen at the flange of the crucible and the top of the heating block.

9.6 Check that the readings can be obtained on the manometer scale, or other measuring device, by connecting the crucible to the assembled apparatus. A reading of 20.0 ± 0.2 mm shall be obtained.

9.7 Disconnect and remove the crucible from the assembled apparatus.

9.8 Switch off the pump and the heating block and raise the crucible and the thermometers from the molten Woods metal. Using the brush, return any Woods metal clinging to the crucible to the heating block.

9.9 Clean the Y-piece and glass tubing to prevent a build up of condensate.

10. Verification

10.1 Switch on the pump and the heating block and ensure that the apparatus is assembled, minus the crucible, as shown in Fig. 5.

10.2 Check that the crucible and cover are free from lacquer.

10.2.1 After every test, clean the crucible and cover with solvent and allow to dry. Stubborn lacquer can be cleaned by

abrasion from a glass beader under pressure.

10.3 Pass the reamer through each of the three nozzles in the cover to ensure that they are clear. (**Warning**—Using a reamer with a diameter larger than 2 mm can enlarge the nozzles. This can lead to higher losses because of increased air flow.)

10.4 Run the ball bearing through the extraction tube to ensure that it is clear of dirt.

10.5 Weigh the empty crucible without its cover to the nearest 0.01 g.

10.6 Weigh into the crucible 65.0 ± 0.1 g of the Reference Oil.

10.7 Screw on the cover using the clamp and spanner.

10.8 Ensure the temperature of the heating block is at $250 \pm 0.5^\circ\text{C}$. Place the crucible in its recess in the heating block, securing the flange under the screw heads against the buoyancy of the Woods metal. Switch the control of the heating block to compensate for the heat capacity of the crucible. Immediately (in less than 5 s), connect the extraction tube of the crucible to the arm of the glass Y-piece, making a butt joint. Simultaneously, start the pump and the stopwatch and adjust the bleed valve to give a pressure differential of 20 ± 0.2 mm.

NOTE 3—When the crucible is in the test position, its flange should be flush with the top of the heating block. Any protrusion of the crucible flange above the heating block may suggest a build-up of Woods metal slag at the bottom of the heating block recess. The heating block and the thermometer recesses should be cleaned and the Woods metal replaced on

D 5800 – 00a^{e1}

(NICKEL-PLATED BRASS)

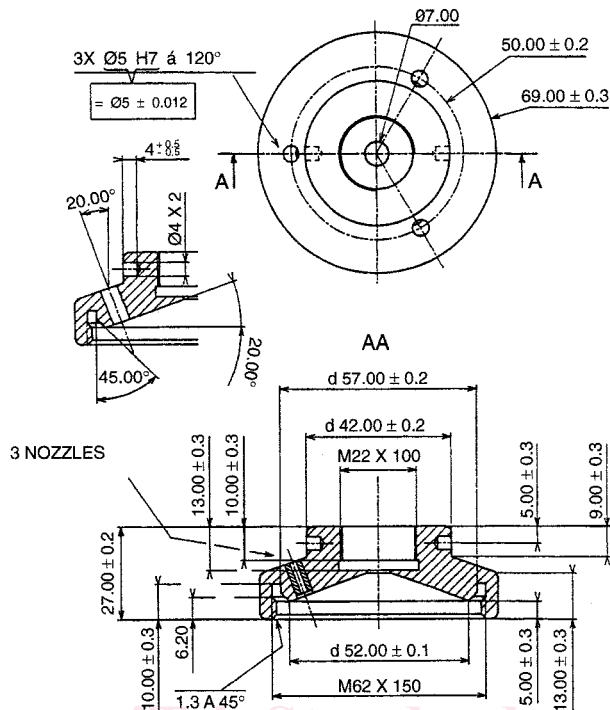

NOTE 1—All dimensions in millilitres.

FIG. 3 Cover

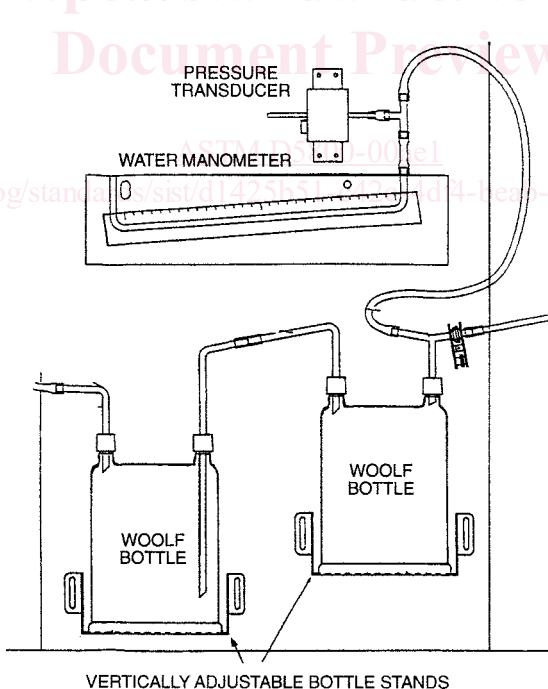

FIG. 4 Glassware

a regular basis to avoid the accumulation of slag. Oxidized Woods metal will affect the heat transfer to the crucible and hence may have a deleterious effect on the results obtained.

10.9 Adjust the control on the heating block to maintain the block temperature approximately 5°C below the test temperature. Readjust the temperature control so that the test tempera-

ture is reestablished within 3 min of the start of the test.

NOTE 4—Temperature and pressure will be controlled automatically when automated equipment is used.

10.10 At the start of the test, constant attention shall be paid to maintaining the correct pressure. Once this becomes steady,

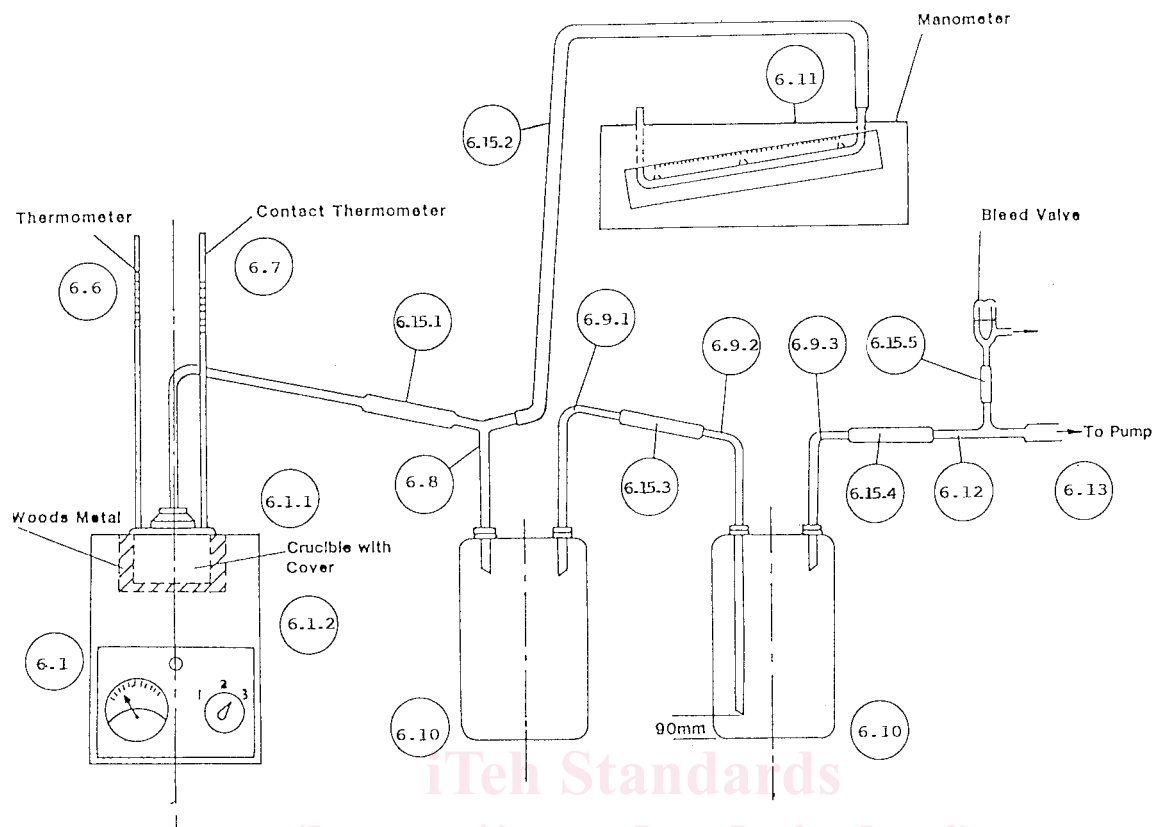

FIG. 5 Test Apparatus

usually within 10 to 15 min, check periodically that the temperature and pressure differential remain constant throughout the period of the test.

10.11 After 60 min \pm 5 s, lift the crucible from the heating block, remove any adhering alloy, and place the crucible in a warm water bath to a depth of at least 30 mm. The time period from the end of the test to immersion of the crucible shall not exceed 60 s.

10.12 After 30 min, remove the crucible from the water, dry the outside, and carefully remove the lid.

10.13 Reweigh the crucible without the lid to the nearest 0.01 g.

10.14 Calculate to the nearest 0.1 % mass/mass (M/M) the evaporation loss of the Reference Oil.

10.15 Compare the result obtained against the given value for the Reference Oil. If the result is within 6 % of the value, repeat the procedure from 11.1, using the test sample.

10.16 If the result is not within 6 % of the given value, check that the apparatus complies with that shown in Fig. 5, and that the procedure has been adhered to. Check the calibration of the thermometer and pressure sensing device.

10.17 Recheck the evaporation loss of the reference oil.

NOTE 5—Condensate should not be allowed to build up in the 2-L glass bottles. These should be washed out with solvent before a maximum 1 cm of condensate collects.

NOTE 6—The equipment should be referenced approximately every ten tests if the test is used frequently. If the testing is infrequent, the equipment should be referenced before the first sample is run.

11. Procedure

11.1 Weigh into a tarred crucible 65 ± 0.1 g representative

of the test sample to a precision of 0.01 g.

NOTE 7—Sample in accordance with Practice D 4057 or D 4177.

11.2 Proceed as described in 10.7 to 10.12.

11.3 Calculate to the nearest 0.1 % M/M the evaporation loss of the sample.

12. Calculations and Results

12.1 Evaporation loss is obtained from the difference in weight before and after 1 h at 250°C.

$$\text{evaporation loss} = \frac{(B - A) - (C - A)}{B - A} \times 100 \quad (1)$$

where:

- A = empty crucible weight,
- B = crucible plus sample weight, and
- C = crucible plus sample after 1 h of heating.

13. Report

13.1 Report the following information:

13.1.1 The nearest 0.1 % M/M as evaporation loss (Test Method D 5800).

14. Precision and Bias

14.1 The interlaboratory round robin used manual, semi-automated, and automated equipment. The precision values were calculated on the statistical examinations of interlaboratory test results as follows.

14.1.1 *Repeatability*—A quantitative measurement of precision associated with single results obtained by the same operator with the same equipment in the same laboratory