**Paints and varnishes — Determination
of resistance to humidity —**

**Part 3:
Condensation (in-cabinet exposure
with heated, bubbling water
reservoir)**

iTeh STANDARD PREVIEW
(standards.iteh.ai)

*Peintures et vernis — Détermination de la résistance à l'humidité —
Partie 3: Condensation (exposition dans une étuve avec barboteur
chauffé)*

ISO 6270-3:2018

<https://standards.iteh.ai/catalog/standards/sist/70e8db2b-d054-4909-bda0-b6fafe1242db/iso-6270-3-2018>



iTeh STANDARD PREVIEW
(standards.iteh.ai)

ISO 6270-3:2018

<https://standards.iteh.ai/catalog/standards/sist/70e8db2b-d054-4909-bda0-b6fafe1242db/iso-6270-3-2018>



COPYRIGHT PROTECTED DOCUMENT

© ISO 2018

All rights reserved. Unless otherwise specified, or required in the context of its implementation, no part of this publication may be reproduced or utilized otherwise in any form or by any means, electronic or mechanical, including photocopying, or posting on the internet or an intranet, without prior written permission. Permission can be requested from either ISO at the address below or ISO's member body in the country of the requester.

ISO copyright office
CP 401 • Ch. de Blandonnet 8
CH-1214 Vernier, Geneva, Switzerland
Tel. +41 22 749 01 11
Fax +41 22 749 09 47
copyright@iso.org
www.iso.org

Published in Switzerland

Contents

	Page
Foreword.....	iv
Introduction.....	v
1 Scope	1
2 Normative references	1
3 Terms and definitions	1
4 Principle	1
5 Limitations	2
6 Apparatus	2
7 Test specimens	3
7.1 Material and dimensions.....	3
7.2 Preparation and coating.....	4
7.3 Drying and conditioning.....	4
7.4 Thickness of coating.....	4
8 Procedure	4
8.1 Arrangement of test specimens.....	4
8.2 Start-up.....	5
8.3 Set of test specimens.....	5
8.4 Duration of test.....	5
9 Evaluation	5
10 Precision	5
11 Test report	5
Bibliography	7

iTech STANDARD PREVIEW

(standards.iteh.ai)

ISO 6270-3:2018

<https://standards.iteh.ai/catalog/standards/sist/70e8db2b-d054-4909-bda0-b6fae1242db/iso-6270-3-2018>

Foreword

ISO (the International Organization for Standardization) is a worldwide federation of national standards bodies (ISO member bodies). The work of preparing International Standards is normally carried out through ISO technical committees. Each member body interested in a subject for which a technical committee has been established has the right to be represented on that committee. International organizations, governmental and non-governmental, in liaison with ISO, also take part in the work. ISO collaborates closely with the International Electrotechnical Commission (IEC) on all matters of electrotechnical standardization.

The procedures used to develop this document and those intended for its further maintenance are described in the ISO/IEC Directives, Part 1. In particular the different approval criteria needed for the different types of ISO documents should be noted. This document was drafted in accordance with the editorial rules of the ISO/IEC Directives, Part 2 (see www.iso.org/directives).

Attention is drawn to the possibility that some of the elements of this document may be the subject of patent rights. ISO shall not be held responsible for identifying any or all such patent rights. Details of any patent rights identified during the development of the document will be in the Introduction and/or on the ISO list of patent declarations received (see www.iso.org/patents).

Any trade name used in this document is information given for the convenience of users and does not constitute an endorsement.

For an explanation on the voluntary nature of standards, the meaning of ISO specific terms and expressions related to conformity assessment, as well as information about ISO's adherence to the World Trade Organization (WTO) principles in the Technical Barriers to Trade (TBT) see the following URL: www.iso.org/iso/foreword.html. (standards.iteh.ai)

This document was prepared by Technical Committee ISO/TC 35, *Paints and varnishes*, Subcommittee SC 9, *General test methods for paints and varnishes*.

A list of all parts in the ISO 6270 series can be found on the ISO website.

Introduction

This document is intended to give consistent conditions and procedures for the conditioning of pre-prepared test specimens which are to be evaluated for defects which can develop when they are subjected to humid ambient atmospheres such as constant condensation-water atmospheres or alternating condensation-water atmospheres.

The tests are designed to clarify the behaviour of the test specimens in humid ambient atmospheres, and to pinpoint any defects in the protection of the test specimens against corrosion. The testing of coatings in these atmospheres does not necessarily give lifetime prediction data.

After conditioning, the test specimens are evaluated either in accordance with documents, such as the appropriate part(s) of ISO 4628, or by procedures agreed between the interested parties.

iTeh STANDARD PREVIEW (standards.iteh.ai)

[ISO 6270-3:2018](https://standards.iteh.ai/catalog/standards/sist/70e8db2b-d054-4909-bda0-b6fafe1242db/iso-6270-3-2018)

<https://standards.iteh.ai/catalog/standards/sist/70e8db2b-d054-4909-bda0-b6fafe1242db/iso-6270-3-2018>

iTeh STANDARD PREVIEW
(standards.iteh.ai)

ISO 6270-3:2018

<https://standards.iteh.ai/catalog/standards/sist/70e8db2b-d054-4909-bda0-b6fafe1242db/iso-6270-3-2018>

Paints and varnishes — Determination of resistance to humidity —

Part 3: Condensation (in-cabinet exposure with heated, bubbling water reservoir)

1 Scope

This document specifies the general conditions and procedures to be observed when testing coated test specimens in constant condensation water atmospheres in order to ensure that the results of tests carried out in different laboratories are reproducible.

NOTE The shape and preparation of the test specimens, the duration of the test and the assessment of the test results are not covered in this document.

2 Normative references

The following documents are referred to in the text in such a way that some or all of their content constitutes requirements of this document. For dated references, only the edition cited applies. For undated references, the latest edition of the referenced document (including any amendments) applies.

ISO 1514, *Paints and varnishes — Standard panels for testing*

ISO 2808, *Paints and varnishes — Determination of film thickness*

ISO 3270, *Paints and varnishes and their raw materials — Temperatures and humidities for conditioning and testing*

ISO 4618, *Paints and varnishes — Terms and definitions*

3 Terms and definitions

For the purposes of this document, the terms and definitions given in ISO 4618 apply.

ISO and IEC maintain terminological databases for use in standardization at the following addresses:

- IEC Electropedia: available at <http://www.electropedia.org/>
- ISO Online browsing platform: available at <https://www.iso.org/obp>

4 Principle

The compressed air is bubbled in heated water and a saturated water vapour is introduced to the test chamber. It makes the supersaturated atmosphere in the test chamber. Under the supersaturated atmosphere, the temperature of the test specimens and the chamber atmosphere becomes almost the same, and continuous condensation takes place. The rotation of the test specimens provides uniform condensation on the test specimens.

5 Limitations

Temperature and humidity are important parameters affecting test results. Deviations from the requirements specified can lead to results that are not comparable. However, the interested parties may agree upon alternative parameters and these parameters shall be reported.

6 Apparatus

6.1 Construction of the apparatus

The apparatus shall be constructed of a chamber, a water reservoir, an air supplier, a specimen rack, a temperature control device, a condensate drip pan, and others (see [Figure 1](#)). All components exposed in high humidity shall be made of corrosion-resistant materials and shall not affect the test specimen(s).

The temperature and humidity sensors shall be installed at a position where the temperature difference between the sensor and the specimens is as small as possible (± 1 °C).

Care shall be taken in regard to the following:

- precautions shall be taken to ensure that no condensation water is allowed to drip onto the test specimens from the walls or ceiling, nor from other test specimens;
- a condensate drip pan shall catch any condensed water dripping from the test specimens.

6.2 Air supply

The compressed air supplied to the chamber shall be passed through a filter to remove all traces of oil or solid. The supplied air bubbles in a water reservoir and is exhausted through the air outlet port (see [Figure 1](#)). An air mass flow is typically about three times the chamber volume per hour.

6.3 Water reservoir

Water in a reservoir shall be deionized water or distilled water.

The water level is held at the prescribed level, (205 ± 5) mm, automatically.

6.4 Specimen rack

6.4.1 Fixed specimen rack

Test specimens shall be mounted on specimen rack at equal intervals.

6.4.2 Rotating specimen rack

Test specimens shall be mounted on rotating specimen rack at equal intervals, and the rotating speed shall be adjusted to $(0,33 \pm 0,02)$ r/min.

6.5 Installation

The apparatus shall be installed in a room with an ambient atmosphere containing no corrosive constituents (e.g. it shall not be installed in a chemical laboratory), at a room temperature of (23 ± 5) °C and at a relative atmospheric humidity of 75 % max., in such a way that it is protected against draughts and solar radiation. In the case of comparison tests, the ambient temperature in the installation room shall be the standard temperature of (23 ± 2) °C in accordance with ISO 3270.

Dimensions in millimetres

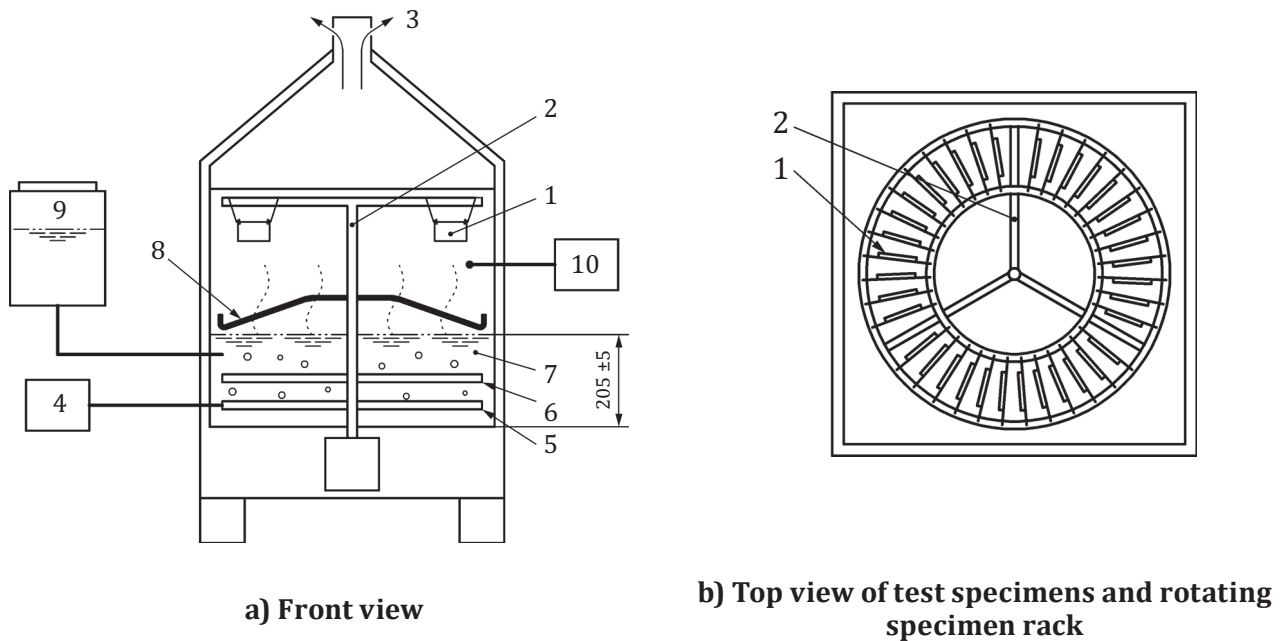

Key

- | | | | |
|---|------------------------|----|----------------------------|
| 1 | test specimen | 6 | heater |
| 2 | rotating specimen rack | 7 | water reservoir |
| 3 | air outlet port | 8 | condensate drip pan |
| 4 | air supplier | 9 | water supply |
| 5 | bubbling device | 10 | temperature control device |

<https://standards.iteh.ai/catalog/standards/sist/70e8db2b-d054-4909-bda0-b6fae1342db/iso-6270-3-2018>

Figure 1 — Example of an apparatus with hooked-up test specimens in a rotating specimen rack

7 Test specimens

7.1 Material and dimensions

Unless otherwise specified or agreed, the test specimens shall be of burnished steel complying with ISO 1514.

The typical size of test specimens is 75 mm × 150 mm.

NOTE In addition, for suspending the test specimen(s), the holes are provided in two places in the upper left and right of specimen(s), with a diameter of, for example, 5 mm. An example of a test specimen is shown in [Figure 2](#).