

IULTCS

Voting begins on:
2015-10-22

Voting terminates on:
2015-12-22

Leather — Physical and mechanical tests — Determination of tear load —

**Part 2:
Double edge tear**

Cuir — Essais physiques et mécaniques — Détermination de la force de déchirement —

Partie 2: Déchirement des deux bords

*iTeh STANDARD PREVIEW
(standard.itoh.ai)
Full standard/catalog/standards/sale/3185e8f-b0e8-44a5-b740-b5e9e26bda9c/iso-3377-2-2015*

Please see the administrative notes on page iii

RECIPIENTS OF THIS DRAFT ARE INVITED TO SUBMIT, WITH THEIR COMMENTS, NOTIFICATION OF ANY RELEVANT PATENT RIGHTS OF WHICH THEY ARE AWARE AND TO PROVIDE SUPPORTING DOCUMENTATION.

IN ADDITION TO THEIR EVALUATION AS BEING ACCEPTABLE FOR INDUSTRIAL, TECHNOLOGICAL, COMMERCIAL AND USER PURPOSES, DRAFT INTERNATIONAL STANDARDS MAY ON OCCASION HAVE TO BE CONSIDERED IN THE LIGHT OF THEIR POTENTIAL TO BECOME STANDARDS TO WHICH REFERENCE MAY BE MADE IN NATIONAL REGULATIONS.



Reference numbers
ISO/FDIS 3377-2:2015(E)
IUP 8:2015(E)

ISO/CEN PARALLEL PROCESSING

This final draft has been developed within the International Organization for Standardization (ISO), and processed under the **ISO-lead** mode of collaboration as defined in the Vienna Agreement. The final draft was established on the basis of comments received during a parallel enquiry on the draft.

This final draft is hereby submitted to the ISO member bodies and to the CEN member bodies for a parallel two-month approval vote in ISO and formal vote in CEN.

Positive votes shall not be accompanied by comments.

Negative votes shall be accompanied by the relevant technical reasons.

iTeh STANDARD PREVIEW
(standards.iteh.ai)
Full standard:
<https://standards.iteh.ai/catalog/standards/sist/e3f85e8f-b0e8-44a5-b740-b5e9e26bda9c/iso-3377-2-2016>



COPYRIGHT PROTECTED DOCUMENT

© ISO 2015, Published in Switzerland

All rights reserved. Unless otherwise specified, no part of this publication may be reproduced or utilized otherwise in any form or by any means, electronic or mechanical, including photocopying, or posting on the internet or an intranet, without prior written permission. Permission can be requested from either ISO at the address below or ISO's member body in the country of the requester.

ISO copyright office
Ch. de Blandonnet 8 • CP 401
CH-1214 Vernier, Geneva, Switzerland
Tel. +41 22 749 01 11
Fax +41 22 749 09 47
copyright@iso.org
www.iso.org

Contents

	Page
Foreword	iv
1 Scope	1
2 Normative references	1
3 Principle	1
4 Apparatus	1
5 Sampling and sample preparation	2
6 Procedure	2
7 Test report	3

iTeh STANDARD PREVIEW
(standards.iteh.ai)

Full standard:
<https://standards.iteh.ai/catalog/standards/sist/e3f85e8f-b0c8-44a5-b740-b5e9e26bda9c/iso-3377-2-2016>

Foreword

ISO (the International Organization for Standardization) is a worldwide federation of national standards bodies (ISO member bodies). The work of preparing International Standards is normally carried out through ISO technical committees. Each member body interested in a subject for which a technical committee has been established has the right to be represented on that committee. International organizations, governmental and non-governmental, in liaison with ISO, also take part in the work. ISO collaborates closely with the International Electrotechnical Commission (IEC) on all matters of electrotechnical standardization.

The procedures used to develop this document and those intended for its further maintenance are described in the ISO/IEC Directives, Part 1. In particular the different approval criteria needed for the different types of ISO documents should be noted. This document was drafted in accordance with the editorial rules of the ISO/IEC Directives, Part 2 (see www.iso.org/directives).

Attention is drawn to the possibility that some of the elements of this document may be the subject of patent rights. ISO shall not be held responsible for identifying any or all such patent rights. Details of any patent rights identified during the development of the document will be in the Introduction and/or on the ISO list of patent declarations received (see www.iso.org/patents).

Any trade name used in this document is information given for the convenience of users and does not constitute an endorsement.

For an explanation on the meaning of ISO specific terms and expressions related to conformity assessment, as well as information about ISO's adherence to the WTO principles in the Technical Barriers to Trade (TBT) see the following URL: [Foreword - Supplementary information](#)

ISO 3377-2 was prepared by the Physical Test Commission of the International Union of Leather Technologists and Chemists Societies (IUP Commission, IULTCS) in collaboration with the European Committee for Standardization (CEN) Technical Committee CEN/TC 289, *Leather*, the secretariat of which is held by UNI, in accordance with the Agreement on technical cooperation between ISO and CEN (Vienna Agreement).

It is based on IUP 8 originally published in *J. Soc. Leather Trades Chemists* **44**, p. 368, (1960) and declared an official method of the IULTCS in 1961. This updated version was published in *J. Soc. Leather Tech. Chem.* **84**, p. 327, (2000) and reconfirmed as an official method in March 2001. The same principle is used but the text has been updated and includes the number of test pieces to be taken.

IULTCS, originally formed in 1897, is a world-wide organization of professional leather societies to further the advancement of leather science and technology. IULTCS has three Commissions, which are responsible for establishing international methods for the sampling and testing of leather. ISO recognizes IULTCS as an international standardizing body for the preparation of test methods for leather.

This second edition cancels and replaces the first edition (ISO 3377-2:2002), of which it constitutes a minor revision to align item f) of Clause 7 with ISO 2419:2012.

ISO 3377 consists of the following parts, under the general title *Leather — Physical and mechanical tests — Determination of tear load*:

- *Part 1: Single edge tear*
- *Part 2: Double edge tear*

Leather — Physical and mechanical tests — Determination of tear load —

Part 2: Double edge tear

1 Scope

This part of ISO 3377 specifies a method for determining the tear strength of leather using a double edged tear. The method is sometimes described as the Baumann tear. It is applicable to all types of leather.

2 Normative references

The following documents, in whole or in part, are normatively referenced in this document and are indispensable for its application. For dated references, only the edition cited applies. For undated references, the latest edition of the referenced document (including any amendments) applies.

ISO 2418, *Leather — Chemical, physical and mechanical and fastness tests — Sampling location*

ISO 2419, *Leather — Physical and mechanical tests — Sample preparation and conditioning*

ISO 2589, *Leather — Physical and mechanical tests — Determination of thickness*

ISO 7500-1, *Metallic materials — Verification of static uniaxial testing machines — Part 1: Tension/compression testing machines – Verification and calibration of the force-measuring system*

3 Principle

A rectangular test piece with a hole of specified shape is placed over the turned up ends of a pair of holders attached to the jaws of a tensile testing machine. The highest force exerted during tearing of the test piece is recorded.

4 Apparatus

4.1 Tensile testing machine, with:

- a force range appropriate to the specimen under test;
- a means of recording the force to an accuracy of at least 2 % as specified by Class 2 of ISO 7500-1;
- a uniform speed of separation of the jaws of 100 mm/min \pm 20 mm/min.

4.2 Test piece holders, such as shown in [Figure 1](#), each consisting of a strip of steel 10 mm \pm 0,1 mm wide and 2 mm \pm 0,1 mm thick, bent through a right angle at one end to form a rigid strip with a minimum length of 12 mm \pm 0,1 mm. The holders either fit into or replace the jaws of the tensile testing machine ([4.1](#)).

4.3 Thickness gauge, as specified in ISO 2589.

4.4 Press knife, as specified in ISO 2419, capable of cutting a test piece as shown in [Figure 2](#) in one operation. All parts of the press knife shall lie in the same plane.

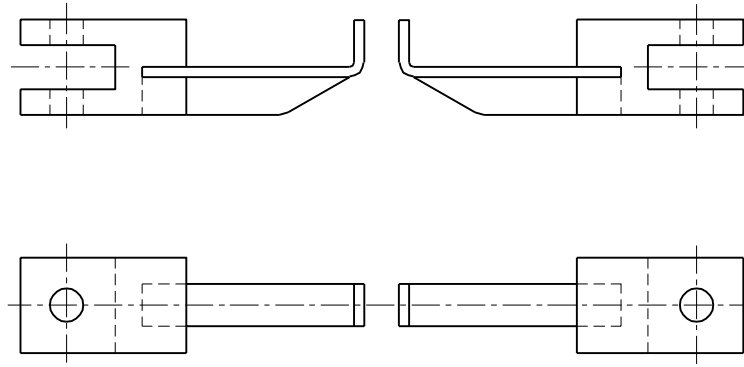
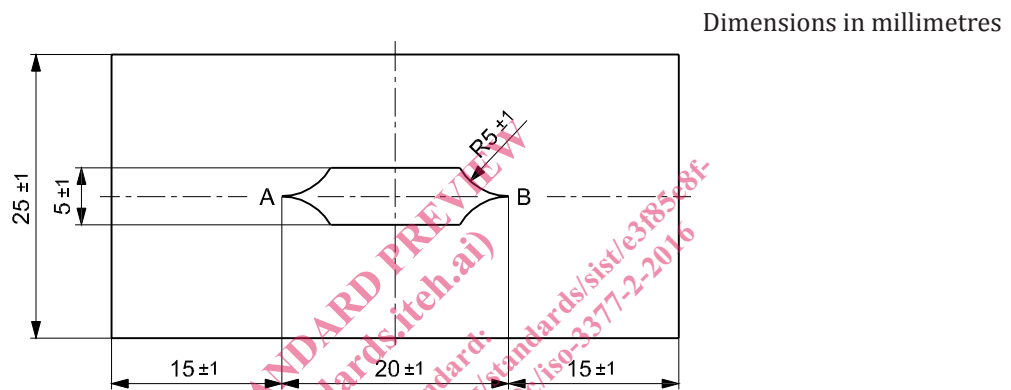

Figure 1 — Test piece holders



Key
R radius

Figure 2 — Test piece for double edge tear

5 Sampling and sample preparation

5.1 Sample in accordance with ISO 2418. From the sample, cut six test pieces in accordance with ISO 2419, three test pieces with the longer sides parallel to the backbone and three test pieces with the longer sides perpendicular to the backbone.

If there is a requirement for more than two hides or skins to be tested in one batch, then only one test piece in each direction need be taken from each hide or skin, provided that the overall total is not less than three test pieces in each direction.

5.2 Condition the test pieces in accordance with ISO 2419.

5.3 Measure the thickness of the test pieces in accordance with ISO 2589.

6 Procedure

6.1 Adjust the apparatus so that the turned up ends of the test piece holders are lightly touching each other. Slip the test piece over the turned up ends so that the ends protrude through the slot with the width of the turned up ends parallel to the straight edges of the slot. Press the test piece firmly onto the holders.

6.2 Run the tensile test machine until the test piece is torn apart and record the maximum force reached during tearing.

6.3 Repeat 6.1 and 6.2 for other test pieces.

7 Test report

The test report shall include the following:

- a) a reference to this part of ISO 3377, i.e. ISO 3377-2;
- b) the thickness of the leather in mm;
- c) the mean tear load in Newtons (N) with the long edge of the test piece cut parallel to the backbone;
- d) the mean tear load in Newtons (N) with the long edge of the test piece cut perpendicular to the backbone;
- e) the average tear load [i.e. the arithmetic mean of c) and d)];
- f) the standard atmosphere used for conditioning and testing, as given in ISO 2419;
- g) any deviations from the method specified in this part of ISO 3377;
- h) full details for identification of the sample and any deviations from ISO 2418 with respect to sampling.

iTeh STANDARD PREVIEW
(standards.iteh.ai)
Full standard:
<https://standards.iteh.ai/catalog/standards/sist/e225e81b0c8-44a5-b740-b5e9e26bda9c/iso-3377-2016>

iTeh STANDARD PREVIEW
(standards.iteh.ai)
Full standard:
<https://standards.iteh.ai/catalog/standards/sist/e3f85e8f-b0c8-44a5-b740-b5e9e26bda9c/iso-3377-2-2016>