**Tool holders with cylindrical shank —
Part 2:
Type A, shanks for tool holders of
special designs**

Porte-outil à queue cylindrique —

Partie 2: Porte-outil de type A de conceptions spéciales

**iTeh STANDARD PREVIEW
(standards.iteh.ai)**

ISO 10889-2:2016

<https://standards.iteh.ai/catalog/standards/sist/20217bb4-be75-4a92-8452-5b55f18eacb6/iso-10889-2-2016>



iTeh STANDARD PREVIEW
(standards.iteh.ai)

ISO 10889-2:2016

<https://standards.iteh.ai/catalog/standards/sist/20217bb4-be75-4a92-8452-5b55f18eacb6/iso-10889-2-2016>



COPYRIGHT PROTECTED DOCUMENT

© ISO 2016, Published in Switzerland

All rights reserved. Unless otherwise specified, no part of this publication may be reproduced or utilized otherwise in any form or by any means, electronic or mechanical, including photocopying, or posting on the internet or an intranet, without prior written permission. Permission can be requested from either ISO at the address below or ISO's member body in the country of the requester.

ISO copyright office
Ch. de Blandonnet 8 • CP 401
CH-1214 Vernier, Geneva, Switzerland
Tel. +41 22 749 01 11
Fax +41 22 749 09 47
copyright@iso.org
www.iso.org

Contents

	Page
Foreword	iv
1 Scope	1
2 Normative references	1
3 Dimensions	1
4 Designation	3
5 Technical delivery conditions	3
Annex A (informative) Relationship between designations in this part of ISO 10889 and ISO 13399	4
Bibliography	5

iTeh STANDARD PREVIEW (standards.iteh.ai)

[ISO 10889-2:2016](https://standards.iteh.ai/catalog/standards/sist/20217bb4-be75-4a92-8452-5b55f18eacb6/iso-10889-2-2016)

<https://standards.iteh.ai/catalog/standards/sist/20217bb4-be75-4a92-8452-5b55f18eacb6/iso-10889-2-2016>

Foreword

ISO (the International Organization for Standardization) is a worldwide federation of national standards bodies (ISO member bodies). The work of preparing International Standards is normally carried out through ISO technical committees. Each member body interested in a subject for which a technical committee has been established has the right to be represented on that committee. International organizations, governmental and non-governmental, in liaison with ISO, also take part in the work. ISO collaborates closely with the International Electrotechnical Commission (IEC) on all matters of electrotechnical standardization.

The procedures used to develop this document and those intended for its further maintenance are described in the ISO/IEC Directives, Part 1. In particular the different approval criteria needed for the different types of ISO documents should be noted. This document was drafted in accordance with the editorial rules of the ISO/IEC Directives, Part 2 (see www.iso.org/directives).

Attention is drawn to the possibility that some of the elements of this document may be the subject of patent rights. ISO shall not be held responsible for identifying any or all such patent rights. Details of any patent rights identified during the development of the document will be in the Introduction and/or on the ISO list of patent declarations received (see www.iso.org/patents).

Any trade name used in this document is information given for the convenience of users and does not constitute an endorsement.

For an explanation on the meaning of ISO specific terms and expressions related to conformity assessment, as well as information about ISO's adherence to the WTO principles in the Technical Barriers to Trade (TBT) see the following URL: [Foreword - Supplementary information](http://standards.iteh.ai)

The committee responsible for this document is ISO/TC 29, *Small tools*, Subcommittee SC 2, *Holding tools, adaptive items and interfaces*.

This third edition cancels and replaces the second edition (ISO 10889-2:2004), of which it constitutes a minor revision, notably with the addition of *Annex A*, which gives the relationship between the designations of this part of ISO 10889 and the ISO 13399 series.

ISO 10889 consists of the following parts, under the general title *Tool holders with cylindrical shank*:

- *Part 1: Cylindrical shank, location bore — Technical delivery conditions*
- *Part 2: Type A, shanks for tool holders of special designs*
- *Part 3: Type B with rectangular radial seat*
- *Part 4: Type C with rectangular axial seat*
- *Part 5: Type D with more than one rectangular seat*
- *Part 6: Type E with cylindrical seat*
- *Part 7: Type F with taper seat*
- *Part 8: Type Z, accessories*

Tool holders with cylindrical shank —

Part 2:

Type A, shanks for tool holders of special designs

1 Scope

This part of ISO 10889 specifies dimensions, designations and complementary technical delivery conditions for tool holders of type A with cylindrical shank in accordance with ISO 10889-1 for tool holders of special designs.

ISO 10889 is applicable to tool holders with cylindrical shank for machine tools with non-rotating tools, preferably for turning machines.

2 Normative references

The following documents, in whole or in part, are normatively referenced in this document and are indispensable for its application. For dated references, only the edition cited applies. For undated references, the latest edition of the referenced document (including any amendments) applies.

ISO 2768-1, *General tolerances — Part 1: Tolerances for linear and angular dimensions without individual tolerance indications*

ISO 2768-2, *General tolerances — Part 2: Geometrical tolerances for features without individual tolerance indications*

ISO 10889-1, *Tool holders with cylindrical shank — Part 1: Cylindrical shank, location bore — Technical delivery conditions*

3 Dimensions

All dimensions and tolerances are given in millimetres. Tolerancing is done according to ISO 8015. Tolerances not specified shall be of tolerance class “m” in accordance with ISO 2768-1 and of class “H” in accordance with ISO 2768-2.

Unspecified details shall be chosen appropriately.

The dimensions of tool holders type A shall be in accordance with the dimensions shown in [Figures 1](#) and [2](#) and given in [Table 1](#).

The relationship between the symbols of this part of ISO 10889 and the symbols according to ISO 13399 is given in [Annex A](#).

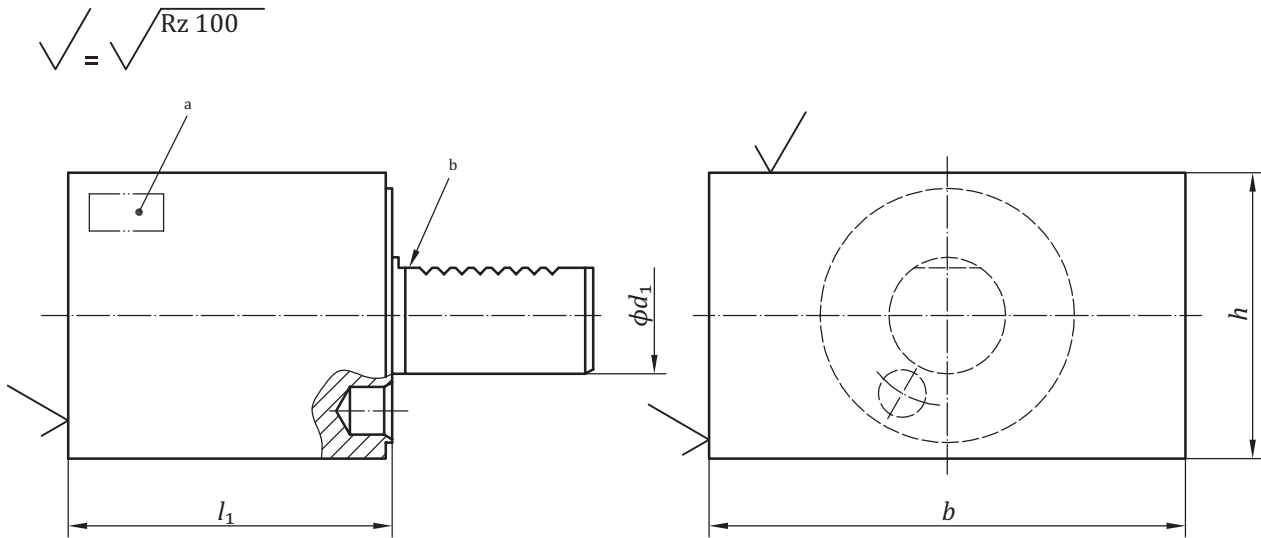

Key

- a Field of marking.
- b Cylindrical shank in accordance with ISO 10889-1.

NOTE Surface roughness is given in micrometres.

Figure 1 — Type A1 tool holder, rectangular
(standards.iteh.ai)

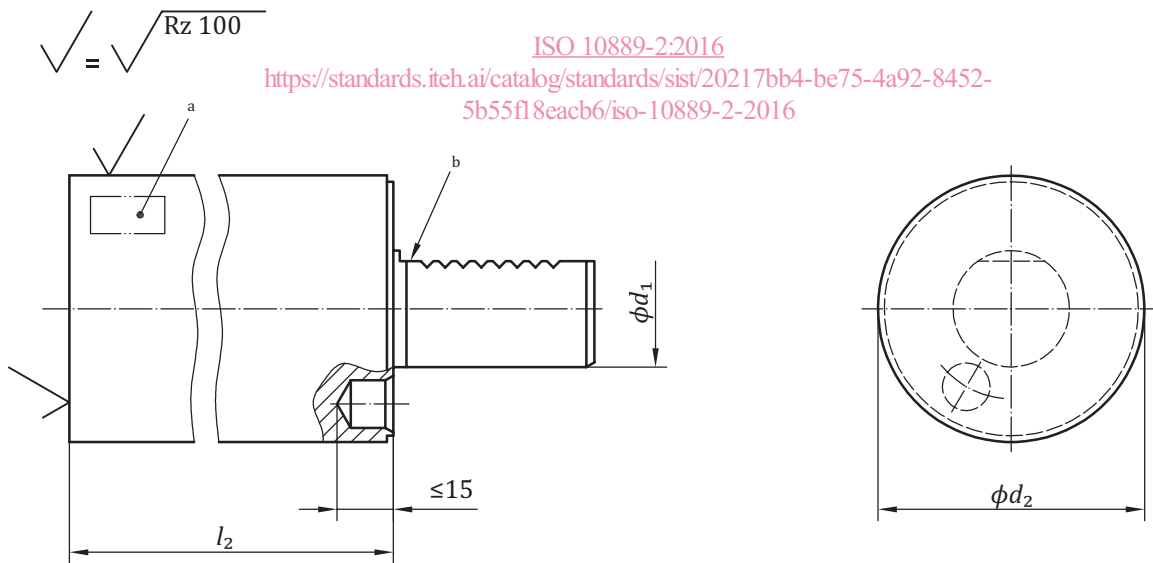

ISO 10889-2:2016
<https://standards.iteh.ai/catalog/standards/sist/20217bb4-be75-4a92-8452-5b55f18eacb6/iso-10889-2-2016>

Key

- a Field of marking.
- b Cylindrical shank in accordance with ISO 10889-1.

NOTE Surface roughness is given in micrometres.

Figure 2 — Type A2 tool holder, round

Table 1 — Type A tool holder dimensions

Dimensions in millimetres

d_1	l_1	l_2	d_2	b	h
16	44	60	40	78	44
20	65	70	50	100	60
25	75	80	58	100	60
		200			
30	85	100	68	130	76
		240			
40	100	120	83	151	96
		320			
50	125	135	98	160	120
		400			
60	160	150	123	165	125
		480			
80	200	500	158	220	160

4 Designation

A tool holder in accordance with this part of ISO 10889 shall be designated by the following:

- a) "Tool holder";
- b) reference to this part of ISO 10889, i.e. ISO 10889-2;
- c) type (A1 or A2);
- d) nominal diameter, d_1 , in millimetres;
- e) nominal length, l_1 or l_2 , in millimetres.

EXAMPLE 1 A tool holder of type A1 with a nominal diameter $d_1 = 40$ mm and a nominal length $l_1 = 100$ mm is designated as follows:

Tool holder ISO 10889-2 - A1 - 40 × 100

EXAMPLE 2 A tool holder of type A2 with a nominal diameter $d_1 = 40$ mm and a nominal length $l_2 = 320$ mm is designated as follows:

Tool holder ISO 1088-2 - A2 - 40 × 320

5 Technical delivery conditions

As a complement to the requirements of ISO 10889-1, the material shall be indicated in the field of marking.

Annex A (informative)

Relationship between designations in this part of ISO 10889 and ISO 13399

For the relationship between the symbols of this part of ISO 10889 and symbols according to ISO 13399, see [Table A.1](#).

Table A.1 — Relationship between symbols in this part of ISO 10889 and ISO 13399 series

Symbol in this part of ISO 10889	Reference in this part of ISO 10889	Property name in ISO 13399	Symbol in ISO 13399	Reference in ISO 13399 (BSU code)
l_1	Figure 1	protruding length	LPR	71DCD394BB20E
l_2	Figure 2	protruding length	LPR	71DCD394BB20E
b	Figure 1	overall width	OAW	71CF299257986
h	Figure 1	overall height	OAH	71D078EB73E87
d_1	Figure 1 and Figure 2	connection diameter machine side	DCONMS	71EBDBF5060E6
d_2	Figure 2	body diameter	BD	71ED6A9AF7D1D

ISO 10889-2:2016

<https://standards.iteh.ai/catalog/standards/sist/20217bb4-be75-4a92-8452-5b55f18eacb6/iso-10889-2-2016>

Bibliography

- [1] ISO 8015, *Geometrical product specifications (GPS) — Fundamentals — Concepts, principles and rules*
- [2] ISO 13399 (all parts), *Cutting tool data representation and exchange*

iTeh STANDARD PREVIEW
(standards.iteh.ai)

[ISO 10889-2:2016](https://standards.iteh.ai/catalog/standards/sist/20217bb4-be75-4a92-8452-5b55f18eacb6/iso-10889-2-2016)

<https://standards.iteh.ai/catalog/standards/sist/20217bb4-be75-4a92-8452-5b55f18eacb6/iso-10889-2-2016>