**Tool holders with cylindrical shank —
Part 4:
Type C with rectangular axial seat**

Porte-outil à queue cylindrique —

Partie 4: Porte-outil axial de type C

**iTeh STANDARD PREVIEW
(standards.iteh.ai)**

[ISO 10889-4:2016](https://standards.iteh.ai/catalog/standards/sist/c078a110-6c02-4a46-a829-c380f648d440/iso-10889-4-2016)

<https://standards.iteh.ai/catalog/standards/sist/c078a110-6c02-4a46-a829-c380f648d440/iso-10889-4-2016>



iTeh STANDARD PREVIEW
(standards.iteh.ai)

ISO 10889-4:2016

<https://standards.iteh.ai/catalog/standards/sist/c078a110-6c02-4a46-a829-c380f648d440/iso-10889-4-2016>



COPYRIGHT PROTECTED DOCUMENT

© ISO 2016, Published in Switzerland

All rights reserved. Unless otherwise specified, no part of this publication may be reproduced or utilized otherwise in any form or by any means, electronic or mechanical, including photocopying, or posting on the internet or an intranet, without prior written permission. Permission can be requested from either ISO at the address below or ISO's member body in the country of the requester.

ISO copyright office
Ch. de Blandonnet 8 • CP 401
CH-1214 Vernier, Geneva, Switzerland
Tel. +41 22 749 01 11
Fax +41 22 749 09 47
copyright@iso.org
www.iso.org

Contents

	Page
Foreword	iv
1 Scope	1
2 Normative references	1
3 Dimensions	1
4 Geometrical tolerances	6
5 Designation	6
6 Technical delivery conditions	6
6.1 General	6
6.2 Design	6
6.3 Scope of delivery	7
Annex A (informative) Relationship between designations in this part of ISO 10889 and ISO 13399	8
Bibliography	10

iTeh STANDARD PREVIEW (standards.iteh.ai)

[ISO 10889-4:2016](https://standards.iteh.ai/catalog/standards/sist/c078a110-6c02-4a46-a829-c380f648d440/iso-10889-4-2016)

<https://standards.iteh.ai/catalog/standards/sist/c078a110-6c02-4a46-a829-c380f648d440/iso-10889-4-2016>

Foreword

ISO (the International Organization for Standardization) is a worldwide federation of national standards bodies (ISO member bodies). The work of preparing International Standards is normally carried out through ISO technical committees. Each member body interested in a subject for which a technical committee has been established has the right to be represented on that committee. International organizations, governmental and non-governmental, in liaison with ISO, also take part in the work. ISO collaborates closely with the International Electrotechnical Commission (IEC) on all matters of electrotechnical standardization.

The procedures used to develop this document and those intended for its further maintenance are described in the ISO/IEC Directives, Part 1. In particular the different approval criteria needed for the different types of ISO documents should be noted. This document was drafted in accordance with the editorial rules of the ISO/IEC Directives, Part 2 (see www.iso.org/directives).

Attention is drawn to the possibility that some of the elements of this document may be the subject of patent rights. ISO shall not be held responsible for identifying any or all such patent rights. Details of any patent rights identified during the development of the document will be in the Introduction and/or on the ISO list of patent declarations received (see www.iso.org/patents).

Any trade name used in this document is information given for the convenience of users and does not constitute an endorsement.

For an explanation on the meaning of ISO specific terms and expressions related to conformity assessment, as well as information about ISO's adherence to the WTO principles in the Technical Barriers to Trade (TBT) see the following URL: [Foreword - Supplementary information](http://www.iso.org/standards/foreword-supplementary-information)

The committee responsible for this document is ISO/TC 29, *Small tools*, Subcommittee SC 2, *Holding tools, adaptive items and interfaces*.

This third edition cancels and replaces the second edition (ISO 10889-4:2004), of which it constitutes a minor revision, notably with the addition of *Annex A*, which gives the relationship between the designations of this part of ISO 10889 and the ISO 13399 series.

ISO 10889 consists of the following parts, under the general title *Tool holders with cylindrical shank*:

- *Part 1: Cylindrical shank, location bore — Technical delivery conditions*
- *Part 2: Type A, shanks for tool holders of special designs*
- *Part 3: Type B with rectangular radial seat*
- *Part 4: Type C with rectangular axial seat*
- *Part 5: Type D with more than one rectangular seat*
- *Part 6: Type E with cylindrical seat*
- *Part 7: Type F with taper seat*
- *Part 8: Type Z, accessories*

Tool holders with cylindrical shank —

Part 4: Type C with rectangular axial seat

1 Scope

This part of ISO 10889 specifies dimensions, designations and complementary technical delivery conditions for tool holders with a rectangular axial seat of types C1 to C4 with cylindrical shank in accordance with ISO 10889-1.

ISO 10889 is applicable to tool holders with cylindrical shank for machine tools with non-rotating tools, preferably for turning machines.

For non-standardized tool holders with rectangular axial seat, such as the tool holders shown in [Figures 1 to 4](#), it is advisable to apply the corresponding specifications of this part of ISO 10889.

2 Normative references

The following documents, in whole or in part, are normatively referenced in this document and are indispensable for its application. For dated references, only the edition cited applies. For undated references, the latest edition of the referenced document (including any amendments) applies.

ISO 2768-1, *General tolerances — Part 1: Tolerances for linear and angular dimensions without individual tolerance indications* <https://standards.iteh.ai/catalog/standards/sist/c078a110-6c02-4a46-a829-c380f648d440/iso-10889-4-2016>

ISO 2768-2, *General tolerances — Part 2: Geometrical tolerances for features without individual tolerance indications*

ISO 8015, *Geometrical product specifications (GPS) — Fundamentals — Concepts, principles and rules*

ISO 10889-1, *Tool holders with cylindrical shank — Part 1: Cylindrical shank, location bore — Technical delivery conditions*

3 Dimensions

All dimensions and tolerances are given in millimetres. Tolerancing is done according to ISO 8015. Tolerances not specified shall be of tolerance class “m” in accordance with ISO 2768-1 and of class “H” in accordance with ISO 2768-2.

Unspecified details shall be chosen appropriately.

The dimensions of tool holders type C shall be in accordance with the dimensions shown in [Figures 1 to 4](#) and given in [Table 1](#).

The relationship between the symbols of this part of ISO 10889 and the symbols according to ISO 13399 is given in [Annex A](#).

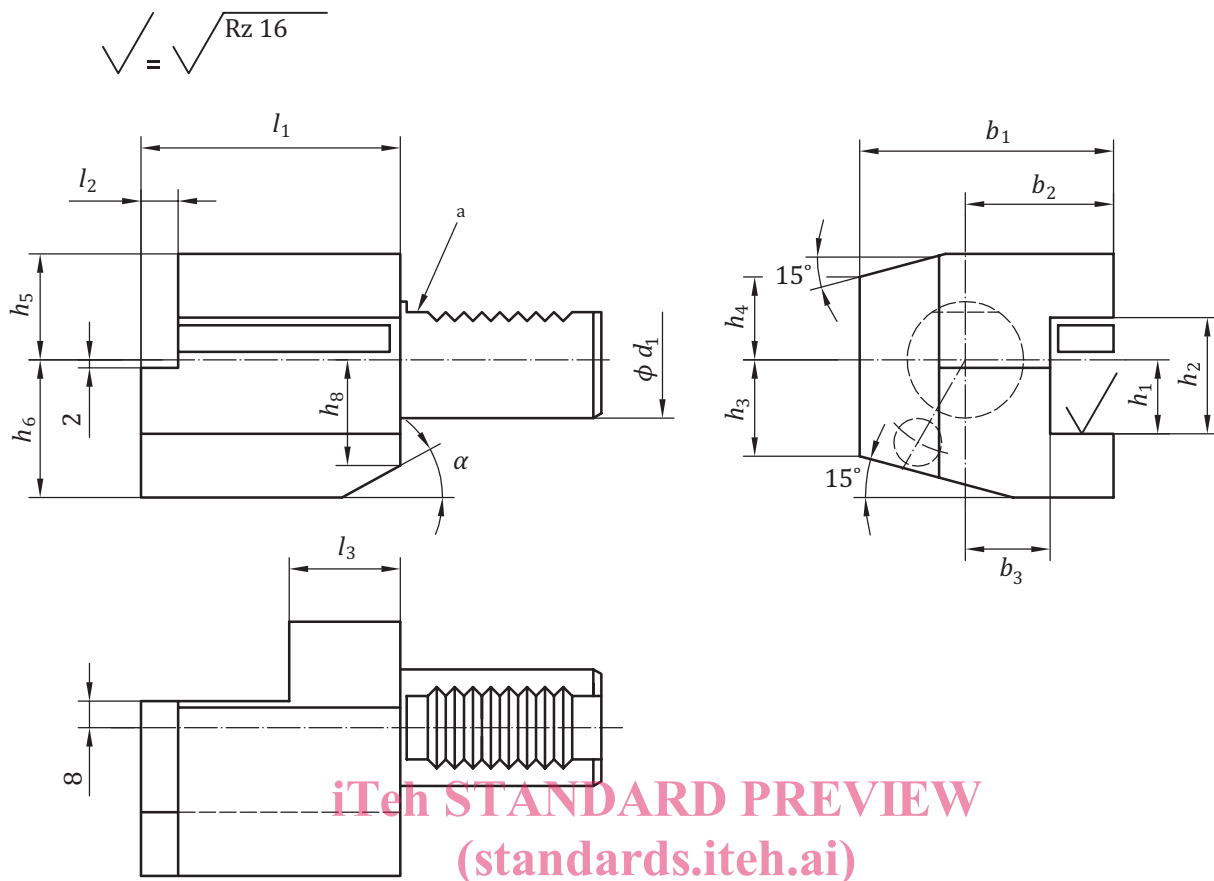

Key

a Cylindrical shank in accordance with ISO 10889-1. <https://standards.iteh.ai/catalog/standards/sist/c078a110-6c02-4a46-a829-c380f548d440/iso-10889-4-2016>

NOTE Surface roughness is given in micrometres.

Figure 1 — Type C1 tool holder, right-hand

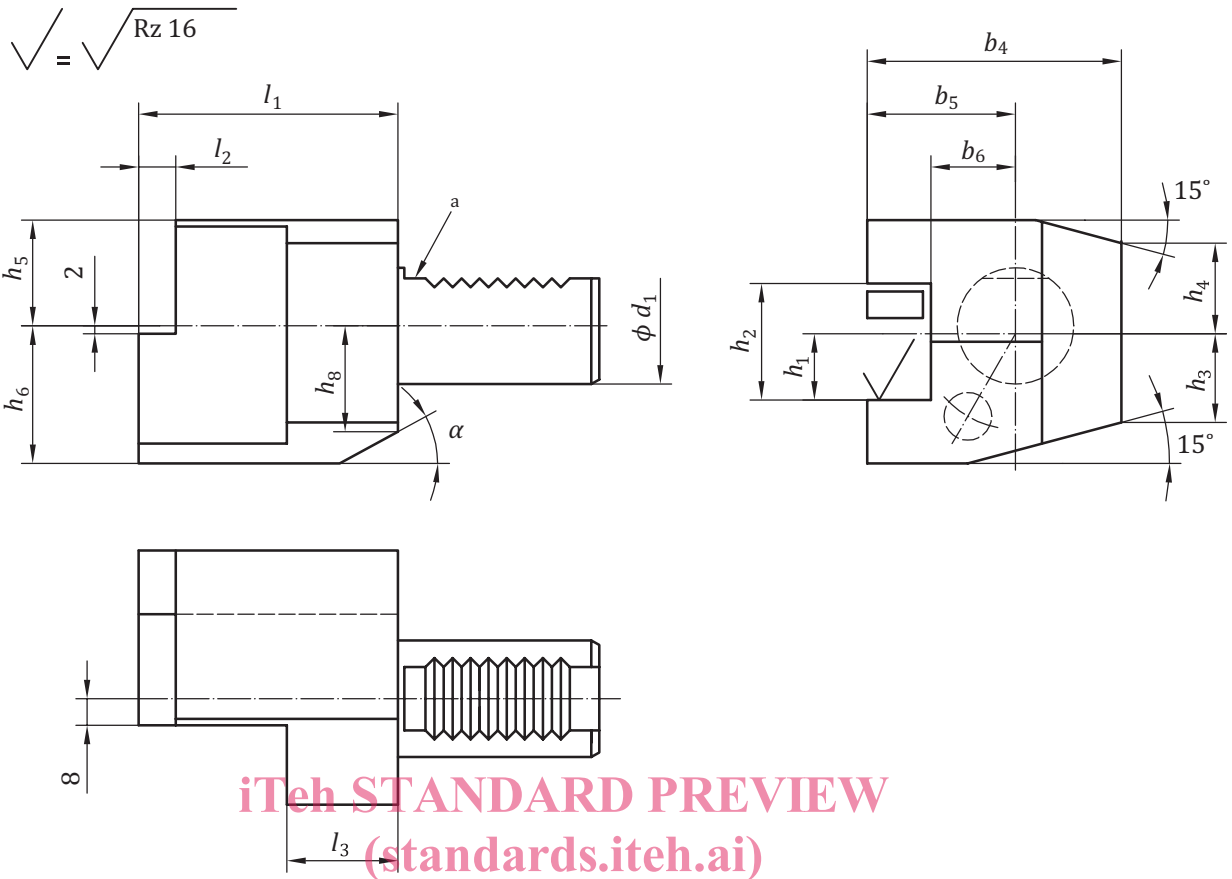

Key

a Cylindrical shank in accordance with ISO 10889-1.
ISO 10889-4:2016
<https://standards.iteh.ai/catalog/standards/sist/c078a110-6c02-4a46-a829-c380f648d440/iso-10889-4-2016>

NOTE Surface roughness is given in micrometres.

Figure 2 — Type C2 tool holder, left-hand

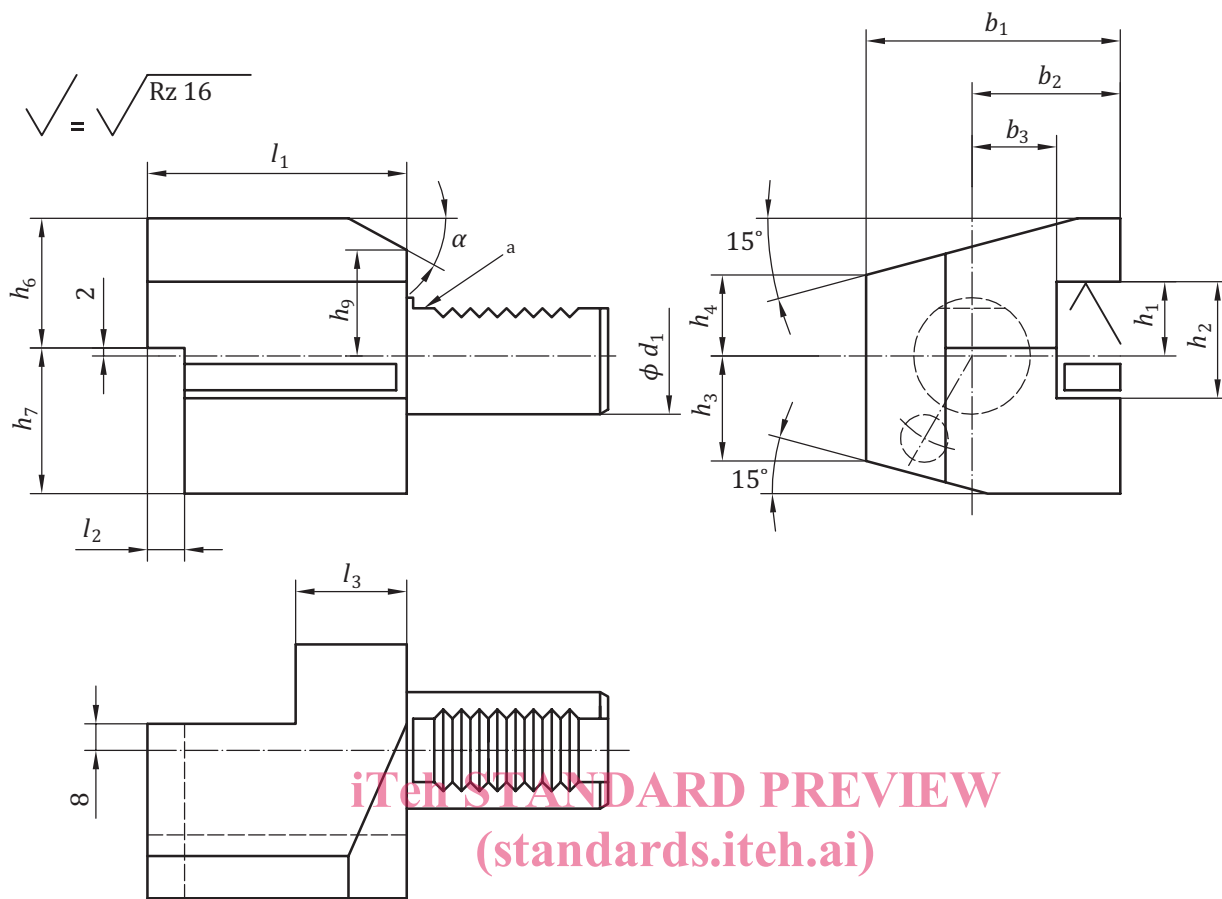

Key

a Cylindrical shank in accordance with ISO 10889-1.

NOTE Surface roughness is given in micrometres.

Figure 3 — Type C3 tool holder, overhead, right-hand

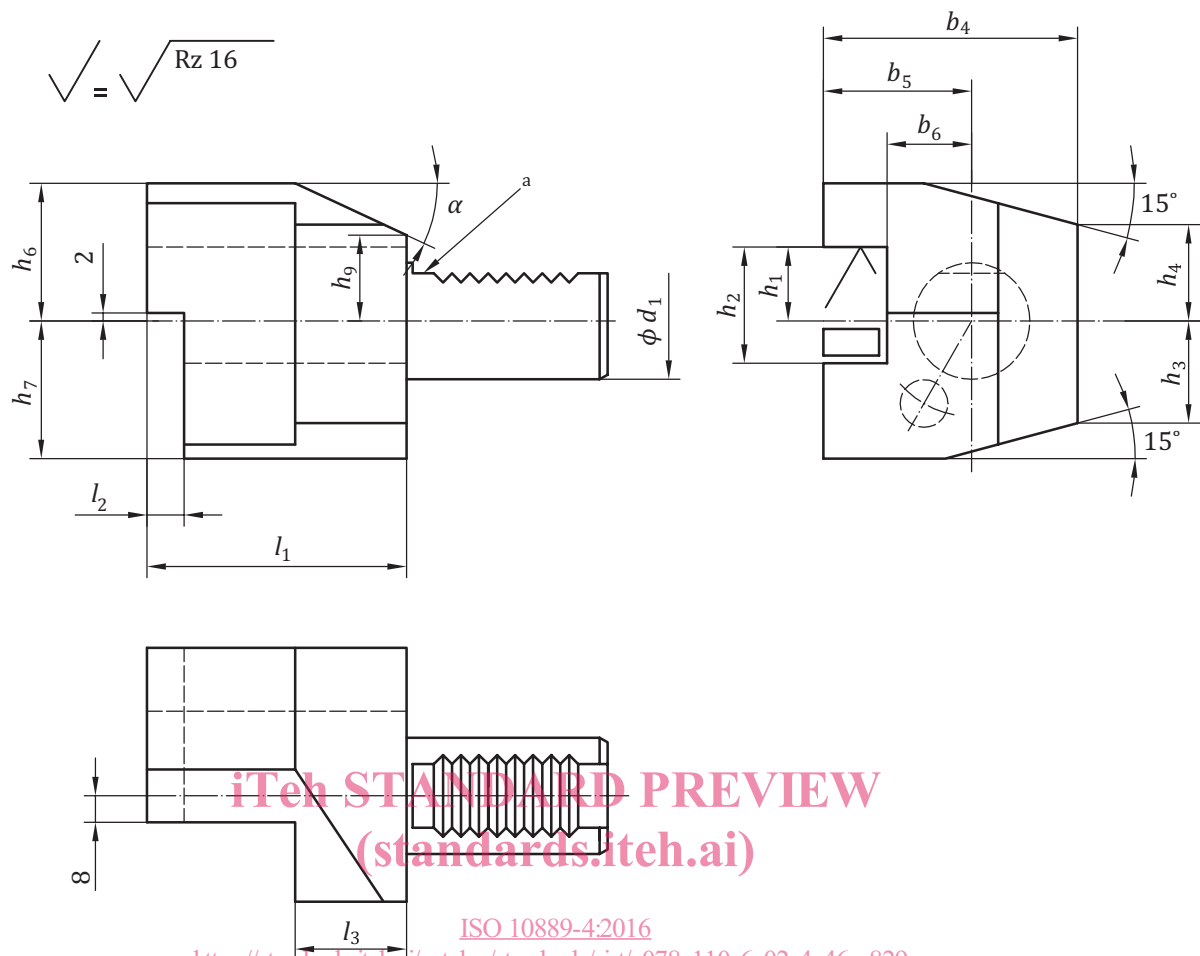

ISO 10889-4:2016
<https://standards.iteh.ai/catalog/standards/sist/c078a110-6c02-4a46-a829-c380f648d440/iso-10889-4-2016>

Key

a Cylindrical shank in accordance with ISO 10889-1.

NOTE Surface roughness is given in micrometres.

Figure 4 — Type C4 tool holder, overhead, left-hand

Table 1 — Type C tool holder dimensions

Dimensions in millimetres

d_1	b_1	b_2	b_3 +0,3 0	b_4	b_5	b_6 +0,3 0	h_1 +0 -0,1	h_2 max.	h_3	h_4	h_5	h_6	h_7	h_8	h_9	l_1	l_2	l_3	α
	Types C1 and C3			Types C1 and C4															
16	43	24	13	43	24	13	12	17	15	15	20	22	20	19	19	44	5	20	30°
20	52	27	13	—	—	—	16	22	19	19	25	30	25	23	23	55	7	30	30°
	65	40	26	65	40	26										50	—		
25	58	33	19	58	33	19	16	22	22,5	22,5	25	30	25	25	25	55	7	20	30°
30	70	35	17	76	41	23	20	29	26	22	28	38	35	30	28	70	10	30	25°
40	85	42,5	21	90	47,5	25,5	25	34	35	30	32,5	48	42,5	—	—	85	12,5	30	—
50	100	50	26	105	55	30,5	32	41	42	35	35	60	50	—	—	100	16	40	—
60	125	62,5	33	125	62,5	33	32	41	46	42,5	42,5	62,5	62,5	—	—	125	16	40	—
80	160	80	42	160	78	42	40	53	60	55	55	80	80	—	—	160	20	40	—