



Designation: ~~C1202-08~~ Designation: C 1202 – 09

Standard Test Method for Electrical Indication of Concrete's Ability to Resist Chloride Ion Penetration¹

This standard is issued under the fixed designation C 1202; the number immediately following the designation indicates the year of original adoption or, in the case of revision, the year of last revision. A number in parentheses indicates the year of last reapproval. A superscript epsilon (ϵ) indicates an editorial change since the last revision or reapproval.

1. Scope*

1.1 This test method covers the determination of the electrical conductance of concrete to provide a rapid indication of its resistance to the penetration of chloride ions. This test method is applicable to types of concrete where correlations have been established between this test procedure and long-term chloride ponding procedures such as those described in AASHTO T 259. Examples of such correlations are discussed in Refs 1-5.²

1.2 The values stated in inch-pound units are to be regarded as the standard, except where SI units are given first followed by inch-pound units in parentheses. The values given in parentheses are for information only.

1.3 *This standard does not purport to address all of the safety concerns, if any, associated with its use. It is the responsibility of the user of this standard to establish appropriate safety and health practices and determine the applicability of regulatory limitations prior to use.*

2. Referenced Documents

2.1 ASTM Standards:³

C 42/C 42M Test Method for Obtaining and Testing Drilled Cores and Sawed Beams of Concrete

C 192/C 192M Practice for Making and Curing Concrete Test Specimens in the Laboratory

C 670 Practice for Preparing Precision and Bias Statements for Test Methods for Construction Materials

2.2 AASHTO Standard:

T 259 Method of Test for Resistance of Concrete to Chloride Ion Penetration⁴

3. Summary of Test Method

3.1 This test method consists of monitoring the amount of electrical current passed through 2-in. (51-mm) thick slices of 4-in. (102-mm) nominal diameter cores or cylinders during a 6-h period. A potential difference of 60 V dc is maintained across the ends of the specimen, one of which is immersed in a sodium chloride solution, the other in a sodium hydroxide solution. The total charge passed, in coulombs, has been found to be related to the resistance of the specimen to chloride ion penetration.

4. Significance and Use

4.1 This test method covers the laboratory evaluation of the electrical conductance of concrete samples to provide a rapid indication of their resistance to chloride ion penetration. In most cases the electrical conductance results have shown good correlation with chloride ponding tests, such as AASHTO T259, on companion slabs cast from the same concrete mixtures (Refs 1-5).

4.2 This test method is suitable for evaluation of materials and material proportions for design purposes and research and development.

4.3 Sample age has significant effects on the test results, depending on the type of concrete and the curing procedure. Most concretes, if properly cured, become progressively and significantly less permeable with time.

4.4 This test method was developed originally for evaluations of alternative materials, but in practice its use has evolved to applications such as quality control and acceptance testing. In such cases it is imperative that the curing procedures and the age at time of testing be clearly defined—specified.

¹ This test method is under the jurisdiction of ASTM Committee C09 on Concrete and Concrete Aggregates and is the direct responsibility of Subcommittee C09.66 on Concrete's Resistance to Fluid Penetration.

Current edition approved Dec. 15, 2008; May 1, 2009. Published January May 2009. Originally approved in 1991. Last previous edition approved in 2007/2008 as C 1202 – 078.

² The boldface numbers in parentheses refer to the list of references at the end of this standard.

³ For referenced ASTM standards, visit the ASTM website, www.astm.org, or contact ASTM Customer Service at service@astm.org. For Annual Book of ASTM Standards volume information, refer to the standard's Document Summary page on the ASTM website.

⁴ Methods of Sampling and Testing, 1986, American Association of State Highway and Transportation Officials, 444 N. Capitol St., NW, Washington, DC 20001.

*A Summary of Changes section appears at the end of this standard.

4.5 Table 1 provides a qualitative relationship between the results of this test and the chloride ion penetrability of concrete.

4.6 Care should be taken in interpreting results of this test when it is used on surface-treated concretes, for example, concretes treated with penetrating sealers. The results from this test on some such concretes indicate low resistance to chloride ion penetration, while 90-day chloride ponding tests on companion slabs show a higher resistance.

4.7 The details of the test method apply to 4-in. (102-mm) nominal diameter specimens. This includes specimens with actual diameters ranging from 3.75 in. (95 mm) to 4.0 in. (102 mm). Other specimen diameters may be tested with appropriate changes in the applied voltage cell design (see 7.5 and Fig. 1).

4.7.1 For specimen diameters other than 3.75 in. (95 mm), the test result value for total charge passed must be adjusted following the procedure in 11.2. For specimens with diameters less than 3.75 in. (95 mm), particular care must be taken in coating and mounting the specimens to ensure that the conductive solutions are able to contact the entire end areas during the test.

5. Interferences

5.1 This test method can produce misleading results when calcium nitrite has been admixed into a concrete. The results from this test on some such concretes indicate higher coulomb values, that is, lower resistance to chloride ion penetration, than from tests on identical concrete mixtures (controls) without calcium nitrite. However, long-term chloride ponding tests indicate the concretes with calcium nitrite were at least as resistant to chloride ion penetration as the control mixtures.

NOTE 1—Other admixtures might affect results of this test similarly. Long term ponding tests are recommended if an admixture effect is suspected.

5.2 Since the test results are a function of the electrical resistance of the specimen, the presence of reinforcing steel or other embedded electrically conductive materials may have a significant effect. The test is not valid for specimens containing reinforcing steel positioned longitudinally, that is, providing a continuous electrical path between the two ends of the specimen.

6. Apparatus

6.1 *Vacuum Saturation Apparatus* (see Fig. 2 for example):

6.1.1 *Separatory Funnel*, or other sealable, bottom-draining container with a minimum capacity of 500 mL.

6.1.2 *Beaker (1000 mL or larger) or other container*—Capable of holding concrete specimen(s) and water and of fitting into vacuum desiccator (see 6.1.3).

6.1.3 *Vacuum Desiccator*—250-mm (9.8-in.) inside diameter or larger. Desiccator must allow two hose connections through a rubber stopper and sleeve or through a rubber stopper only. Each connection must be equipped with a stopcock.

6.1.4 *Vacuum Pump or Aspirator*—Capable of maintaining a pressure of less than 50 mm Hg (6650 Pa) in desiccator.

NOTE 2—Since vacuum will be drawn over water, a vacuum pump should be protected with a water trap, or pump oil should be changed after each operation.

6.1.5 *Vacuum Gage or Manometer*—Accurate to ± 5 mm Hg (± 665 Pa) over range 0–100 mm Hg (0–13300 Pa) pressure.

6.2 *Coating Apparatus and Materials* :

6.2.1 *Coating*—Rapid setting, electrically nonconductive, capable of sealing side surface of concrete cores.

6.2.2 *Balance or Scale, Paper Cups, Wooden Spatulas, and Disposable Brushes*—For mixing and applying coating.

6.3 *Specimen Sizing Equipment* (not required if samples are cast to final specimen size).

6.3.1 *Movable Bed Water-Cooled Diamond Saw or Silicon Carbide Saw*.

7. Reagents, Materials, and Test Cell

7.1 *Specimen-Cell Sealant*—Capable of sealing concrete to poly (methyl methacrylate), for example, Plexiglas, against water and dilute sodium hydroxide and sodium chloride solutions at temperatures up to 200 °F (90 °C); examples include RTV silicone rubbers, silicone rubber caulking, other synthetic rubber sealants, silicone greases, and rubber gaskets.

7.2 *Sodium Chloride Solution*—3.0 % by mass (reagent grade) in distilled water.

7.3 *Sodium Hydroxide Solution*—0.3 N (reagent grade) in distilled water.

7.3.1 **Warning**—Before using NaOH, review: (1) the safety precautions for using NaOH; (2) first aid for burns; and (3) the emergency response to spills, as described in the manufacturer's Material Safety Data Sheet or other reliable safety literature. NaOH can cause very severe burns and injury to unprotected skin and eyes. Suitable personal protective equipment should always be used. These should include full-face shields, rubber aprons, and gloves impervious to NaOH. Gloves should be checked periodically for pin holes.

TABLE 1 Chloride Ion Penetrability Based on Charge Passed (1)

Charge Passed (coulombs)	Chloride Ion Penetrability
>4,000	High
2,000–4,000	Moderate
1,000–2,000	Low
100–1,000	Very Low
<100	Negligible

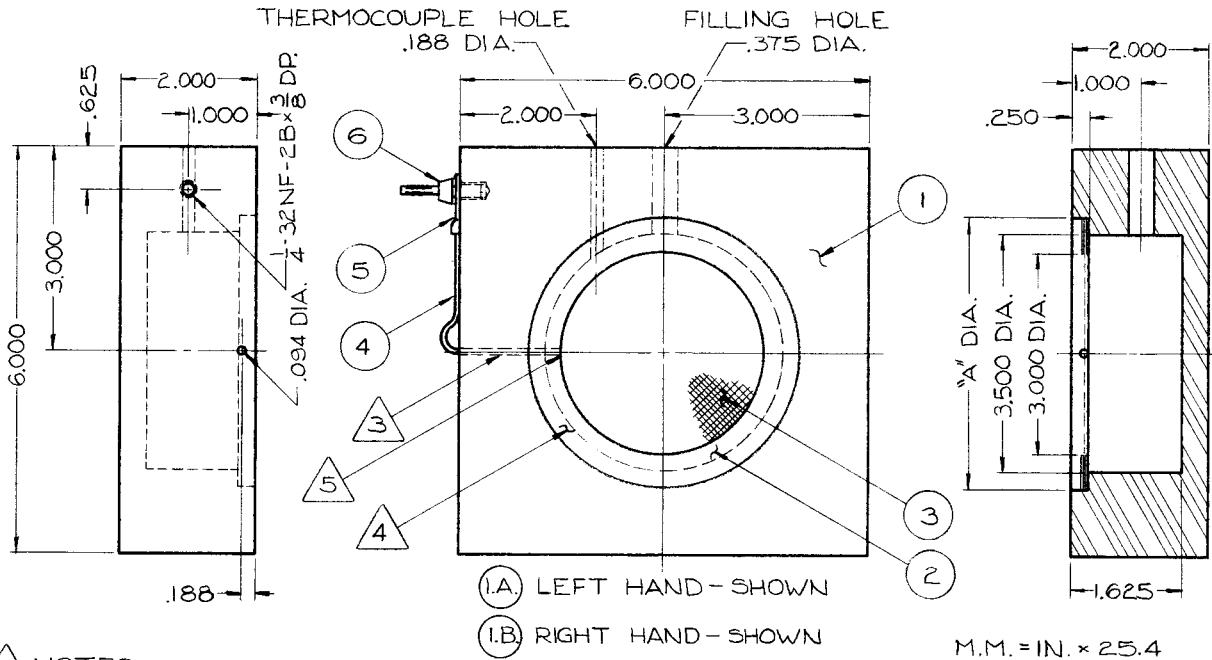

NOTES:

- 1.) DIAMETER "A" SHOULD BE $\frac{1}{8}$ " LARGER THAN OUTSIDE DIA. OF SPECIMEN.
- 2.) NOT TO SCALE.
- 3.) SEAL WIRE IN HOLE WITH SILICONE RUBBER CAULK.
- 4.) SCREEN SOLDERED BETWEEN SHIMS.
- 5.) SOLDER WIRE TO BRASS SHIM.
- 6.) POLYMETHYLMETHACRYLATE, e.g., PLEXIGLAS.

6	2	BANANA PLUG	$\frac{1}{4}$ MALE, INSULATED
5	2	TERMINAL	12-10- $\frac{1}{4}$
4	2	WIRE, COPPER	#14, SOLID NYLCLAD
3	2	SCREEN, BRASS	#20 MESH, "A" DIA.
2	4	SHIM, BRASS	0.02 THK.
1.B.	1	CELL BLOCK END	PMMA SHEET
1.A.	1	CELL BLOCK END	PMMA SHEET
ITEM	QTY.	NOMENCLATURE	SPECIFICATION

FIG. 1 Applied Voltage Cell (construction drawing)

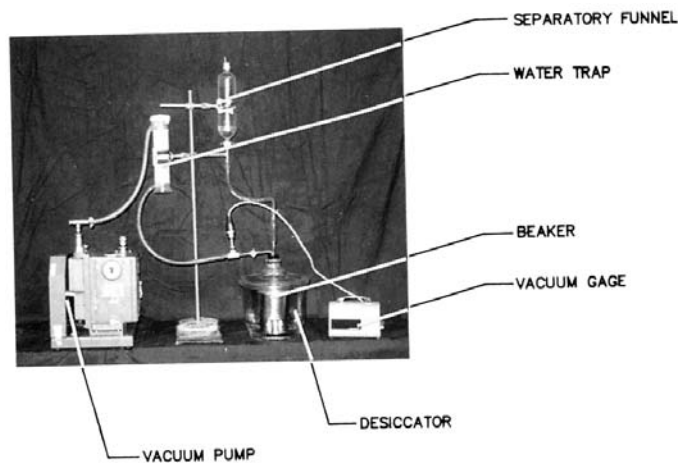

FIG. 2 Vacuum Saturation Apparatus

7.4 *Filter Papers*—No. 2, 90-mm (3.5-in.) diameter (not required if rubber gasket is used for sealant (see 7.1) or if sealant can be applied without overflowing from shim onto mesh).

7.5 *Applied Voltage Cell* (see Fig. 1 and Fig. 3)—Two symmetric poly (methyl methacrylate) chambers, each containing electrically conductive mesh and external connectors. One design in common use is shown in Fig. 1 and Fig. 3. However, other designs are acceptable, provided that overall dimensions (including dimensions of the fluid reservoir) are the same as shown in

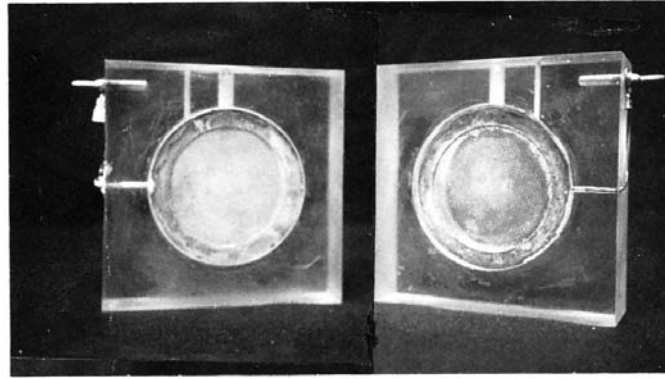

FIG. 3 Applied Voltage Cell-Face View

Fig. 1 and width of the screen and shims are as shown.

7.6 *Temperature Measuring Device (optional)*—30 to 250 °F (0 to 120 °C) range.

7.7 *Voltage Application and Data Readout Apparatus*—Capable of holding 60 ± 0.1 V dc across applied voltage cell over entire range of currents and of displaying voltage accurate to ± 0.1 V and current to ± 1 mA. Apparatus listed in 7.7.1-7.7.5 is a possible system meeting this requirement.

7.7.1 *Voltmeter*—Digital (DVM), 3 digit, minimum 0–99.9 V range, rated accuracy ± 0.1 %.

7.7.2 *Voltmeter*—Digital (DVM), 4½ digit, 0–200 mV range, rated accuracy ± 0.1 %.

7.7.3 *Shunt Resistor*—100 mV, 10A rating, tolerance ± 0.1 %. Alternatively, a 0.01Ω resistor, tolerance ± 0.1 %, may be used, but care must be taken to establish very low resistance connections.

7.7.4 *Constant Voltage Power Supply*— 0–80 V dc, 0–2 A, capable of holding voltage constant at 60 ± 0.1 V over entire range of currents.

7.7.5 *Cable*—Two conductor, No. 14 (1.6 mm), insulated, 600 V.

8. Test Specimens

8.1 Sample preparation and selection depends on the purpose of the test. For evaluation of materials or their proportions, samples may be (a) cores from test slabs or from large diameter cylinders or (b) 4-in. (102-mm) diameter cast cylinders. For evaluation of structures, samples may be (a) cores from the structure or (b) 4-in. (102-mm) diameter cylinders cast and cured at the field site. Coring shall be done with a drilling rig equipped with a 4-in. (102-mm) diameter diamond-dressed core bit. Select and core samples following procedures in Test Method C 42/C 42M. Cylinders cast in the laboratory shall be prepared following procedures in Practice C 192/C 192M. When cylinders are cast in the field to evaluate a structure, care must be taken that the cylinders receive the same treatment as the structure, for example, similar degree of consolidation, curing, and temperature history during curing.

NOTE 3—The maximum allowable aggregate size has not been established for this test. Users have indicated that test repeatability is satisfactory on specimens from the same concrete batch for aggregates up to 25.0 mm (1 in.) nominal maximum size.

8.2 Transport the cores or field-cured cylinders to the laboratory in sealed (tied) plastic bags. If specimens must be shipped, they should be packed so as to be properly protected from freezing and from damage in transit or storage.

8.3 Using the water-cooled diamond saw or silicon carbide saw, cut a $2 \pm \frac{1}{8}$ in. (51 ± 3 mm) slice from the top of the core or cylinder, with the cut parallel to the top of the core. This slice will be the test specimen. Use a belt sander to remove any burrs on the end of the specimen.

8.4 Special processing is necessary for core samples where the surface has been modified, for example, by texturing or by applying curing compounds, sealers, or other surface treatments, and where the intent of the test is not to include the effect of the modifications. In those cases, the modified portion of the core shall be removed and the adjacent $2 \pm \frac{1}{8}$ in. (51 ± 3 mm) slice shall be used for the test.

9. Conditioning

9.1 Vigorously boil a litre or more of tapwater in a large sealable container. Remove container from heat, cap tightly, and allow water to cool to ambient temperature.

9.2 Allow specimen prepared in Section 8 to surface dry in air for at least 1 h. Prepare approximately ½ oz (10 g) of rapid setting coating and brush onto the side surface of specimen. Place the sample on a suitable support while coating to ensure complete coating of sides. Allow coating to cure according to the manufacturer's instructions.

9.3 The coating should be allowed to cure until it is no longer sticky to the touch. Fill any apparent holes in the coating and allow additional curing time, as necessary. Place specimen in beaker or other container (see 6.1.2), then place container in vacuum desiccator. Alternatively, place specimen directly in vacuum desiccator. Both end faces of specimen must be exposed. Seal