



Designation: ~~D1883-05~~ Designation: D 1883 – 07^{ε1}

Standard Test Method for CBR (California Bearing Ratio) of Laboratory-Compacted Soils¹

This standard is issued under the fixed designation D 1883; the number immediately following the designation indicates the year of original adoption or, in the case of revision, the year of last revision. A number in parentheses indicates the year of last reapproval. A superscript epsilon (ϵ) indicates an editorial change since the last revision or reapproval.

This standard has been approved for use by agencies of the Department of Defense.

^{ε1} NOTE—Editorially corrected units in Section 6.2 in May 2009.

1. Scope*

~~1.1 This test method covers the determination of the CBR (California Bearing Ratio) of pavement subgrade, subbase, and base course materials from laboratory compacted specimens. The test method is primarily intended for but not limited to, evaluating the strength of cohesive materials having maximum particle sizes less than $\frac{3}{4}$ in. (19 mm).~~

~~NOTE 1—The agency performing this test can be evaluated in accordance with Practice D3740. Notwithstanding statements on precision and bias contained in this Standard, the precision of this test method is dependent on the competence of the personnel performing it and the suitability of the equipment and facilities used. Agencies which meet the criteria of Practice D3740 are generally considered capable of competent and objective testing. Users of this method are cautioned that compliance with Practice D3740 does not in itself assure reliable testing. Reliable testing depends on many factors; Practice D3740 provides a means of evaluating some of those factors.~~

1.1 This test method covers the determination of the CBR (California Bearing Ratio) of pavement subgrade, subbase, and base course materials from laboratory compacted specimens. The test method is primarily intended for (but not limited to) evaluating the strength of materials having maximum particle sizes less than $\frac{3}{4}$ in. (19 mm).

1.2 When materials having maximum particle sizes greater than $\frac{3}{4}$ in. (19 mm) are to be tested, this test method provides for modifying the gradation of the material so that the material used for tests all passes the $\frac{3}{4}$ -in. sieve while the total gravel (+No. 4 to 3 in.) fraction remains the same. While traditionally this method of specimen preparation has been used to avoid the error inherent in testing materials containing large particles in the CBR test apparatus, the modified material may have significantly different strength properties than the original material. However, a large experience base has developed using this test method for materials for which the gradation has been modified, and satisfactory design methods are in use based on the results of tests using this procedure.

1.3 Past practice has shown that CBR results for those materials having substantial percentages of particles retained on the No. 4 sieve are more variable than for finer materials. Consequently, more trials may be required for these materials to establish a reliable CBR.

1.4 This test method provides for the determination of the CBR of a material at optimum water content or a range of water content from a specified compaction test and a specified dry unit weight. The dry unit weight is usually given as a percentage of maximum dry unit weight determined by Test Methods D 698 or ~~D1557~~ or D 1557.

1.5 The agency requesting the test shall specify the water content or range of water content and the dry unit weight for which the CBR is desired.

1.6 Unless specified otherwise by the requesting agency, or unless it has been shown to have no effect on test results for the material being tested, all specimens shall be soaked prior to penetration.

1.7 For the determination of CBR of field compacted materials, see Test Method D 4429.

1.8 The values stated in inch-pound units are to be regarded as the standard. The SI equivalents shown in parentheses may be approximate.

~~1.9~~
1.9 All observed and calculated values shall conform to the guidelines for significant digits and rounding established in Practice D 6026.

1.9.1 The procedures used to specify how data are collected, recorded or calculated in this standard are regarded as the industry standard. In addition they are representative of the significant digits that generally should be retained. The procedures used do not

¹ This test method is under the jurisdiction of ASTM Committee D18 on Soil and Rock and is the direct responsibility of Subcommittee D18.05 on Strength and Compressibility of Soils.

Current edition approved Nov. 4, 2005-15, 2007. Published December 2005-2007. Originally approved in 1961. Last previous edition approved in 1999-2005 as ~~D1883-99~~-D 1883 – 05.

*A Summary of Changes section appears at the end of this standard.

consider material variation, purpose for obtaining the data, special purpose studies, or any considerations for the user's objectives, and it is common practice to increase or reduce significant digits or reported data to be commensurate with these considerations. It is beyond the scope of this standard to consider significant digits used in analytical methods for engineering design.

1.10 *This standard does not purport to address all of the safety problems, if any, associated with its use. It is the responsibility of the user of this standard to establish appropriate safety and health practices and determine the applicability of regulatory limitations prior to use.*

2. Referenced Documents

2.1 ASTM Standards:²

D 422 [Test Method for Particle-Size Analysis of Soils](#)

D 653 [Terminology Relating to Soil, Rock, and Contained Fluids](#)

D 698 [Test Methods for Laboratory Compaction Characteristics of Soil Using Standard Effort \(12,400\(12 400 ft-lbf/ft³\(600 kN-m/m³\)\)](#)

D 1557 [Test Methods for Laboratory Compaction Characteristics of Soil Using Modified Effort \(56,000 ft-lbf/ft³\(2,700 kN-m/m³\)\)](#)

D 2168 [Test Methods for Calibration of Laboratory Mechanical-Rammer Soil Compactors](#)

D 2216 [Test Methods for Laboratory Determination of Water \(Moisture\) Content of Soil and Rock by Mass](#)

D 2487 [Practice for Classification of Soils for Engineering Purposes \(Unified Soil Classification System\)](#)

D 2488 [Practice for Description and Identification of Soils \(Visual-Manual Procedure\)](#)

D 3740 [Practice for Minimum Requirements for Agencies Engaged in the Testing and/or Inspection of Soil and Rock as Used in Engineering Design and Construction](#)

D 4318 [Test Methods for Liquid Limit, Plastic Limit, and Plasticity Index of Soils](#)

D 4429 [Test Method for CBR \(California Bearing Ratio\) of Soils in Place](#) ~~Test Method for CBR (California Bearing Ratio) of Soils in Place~~

D 4753 [Guide for Evaluating, Selecting, and Specifying Balances and Standard Masses for Use in Soil, Rock, and Construction Materials Testing](#)

D 6026 [Practice for Using Significant Digits in Geotechnical Data](#)

E 11 [Specification for Wire Cloth and Sieves for Testing Purposes](#)

3. Summary of Test Method

3.1 For tests performed on materials compacted at one water content, three specimens are prepared. The specimens are compacted using three different compactive efforts to obtain unit weights both above and below the desired unit weight. After allowing specimens to take on water by soaking, or other specified treatment such as curing, each specimen is subjected to penetration by a cylindrical rod. Results of stress (load) versus penetration depth are plotted to determine the CBR for each specimen. The CBR at the specified density is determined from a graph of CBR versus dry unit weight.

3.2 For tests in which the result is to be determined for a water content range, a series of specimens at each of three compactive efforts are prepared over the range of water contents requested. The compactive efforts are chosen to produce unit weights above and below the desired unit weight. After allowing the specimens to take on water by soaking, or other specified treatment such as curing, each specimen is penetrated. Results are plotted to obtain the CBR for each specimen. A plot of CBR versus unit weight for each water content is made to determine the minimum CBR for the range of water contents requested. [Terminology](#)

3.1 *Definitions:* All definitions are in accordance with Terminology D 653.

3.2 *Definitions of Terms Specific to This Standard:*

3.2.1 *water content of the compaction specimen, w_c* —water content in percent of material used to compact the test specimen.

3.2.2 *water content top 1 in. (25.4-mm) after soaking w_s* —water content in percent of upper 1 in. (25.4 mm) of material removed after soaking and penetration.

3.2.3 *water content after testing, w_f* —water content in percent of material after soaking and final penetration; does not include material described in 3.2.2.

3.2.4 *dry density as compacted and before soaking, ρ_{d1}* —dry density of the as-compacted test specimen using the measured wet mass and calculating the dry mass using the water content defined in 3.2.1.

4. Significance and Use

4.1 This test method is used to evaluate the potential strength of subgrade, subbase, and base course material, including recycled materials for use in road and airfield pavements. The CBR value obtained in this test forms an integral part of several flexible pavement design methods.

4.2 For applications where the effect of compaction water content on CBR is small, such as cohesionless, coarse-grained materials, or where an allowance is made for the effect of differing compaction water contents in the design procedure, the CBR

² For referenced ASTM standards, visit the ASTM website, www.astm.org, or contact ASTM Customer Service at service@astm.org. For *Annual Book of ASTM Standards* volume information, refer to the standard's Document Summary page on the ASTM website.

may be determined at the optimum water content of a specified compaction effort. The dry unit weight specified is normally the minimum percent compaction allowed by the using agency's field compaction specification.

4.3 For applications where the effect of compaction water content on CBR is unknown or where it is desired to account for its effect, the CBR is determined for a range of water contents, usually the range of water content permitted for field compaction by using agency's field compaction specification.

4.4 The criteria for test specimen preparation of self cementing (and other) materials which gain strength with time must be based on a geotechnical engineering evaluation. As directed by the engineer, self cementing materials shall be properly cured until bearing ratios representing long term service conditions can be measured. Summary of Test Method

4.1 The California Bearing Ratio (CBR) test is a load test applied to the surface and used in soil investigations as an aid to the design of pavements. The laboratory test uses a circular piston to penetrate material compacted in a mold at a constant rate of penetration. The CBR is expressed as the ratio of the unit load on the piston required to penetrate 0.1 in. (2.5 mm) and 0.2 in (5 mm) of the test soil to the unit load required to penetrate a standard material of well-graded crushed stone.

4.2 This test method is used to determine the CBR of a material compacted in a specified mold. It is incumbent on the requesting agencies to specify the scope of testing to satisfy agency protocol or specific design requirements. Possible scope of testing includes:

4.2.1 CBR penetration tests are performed on each point of a compaction test performed in accordance with Method C of D 698 or D 1557. The CBR mold with the spacer disk specified in this standard has the same internal dimensions as a 6-in. (150-mm) diameter compaction mold.

4.2.2 Another alternative is for CBR test to be performed on material compacted to a specific water content and density. Alternatively, a water content range may be stated for one or more density values. This will often require a series of specimens prepared using two or three compactive efforts for the specified water content or over the range of water contents requested. The compactive efforts are achieved by following procedures of D 698 or D 1557 but varying the blows per layer to produce densities above and below the desired density.

5. Significance and Use

5.1 This test method is used to evaluate the potential strength of subgrade, subbase, and base course material, including recycled materials for use in road and airfield pavements. The CBR value obtained in this test forms an integral part of several flexible pavement design methods.

5.2 For applications where the effect of compaction water content on CBR is small, such as cohesionless, coarse-grained materials, or where an allowance is made for the effect of differing compaction water contents in the design procedure, the CBR may be determined at the optimum water content of a specified compaction effort. The dry unit weight specified is normally the minimum percent compaction allowed by the using agency's field compaction specification.

5.3 For applications where the effect of compaction water content on CBR is unknown or where it is desired to account for its effect, the CBR is determined for a range of water contents, usually the range of water content permitted for field compaction by using agency's field compaction specification.

5.4 The criteria for test specimen preparation of self cementing (and other) materials which gain strength with time must be based on a geotechnical engineering evaluation. As directed by the engineer, self-cementing materials shall be properly cured until bearing ratios representing long term service conditions can be measured.

NOTE 1—The agency performing this test can be evaluated in accordance with Practice D 3740. Notwithstanding the statements on precision and bias contained in this test method, the precision of this test method is dependent on the competence of the personnel performing it, and the suitability of the equipment and facilities used. Agencies that meet the criteria of Practice D 3740 are generally considered capable of competent and objective testing. Users of this test method are cautioned that compliance with Practice D 3740 does not in itself ensure reliable testing. Reliable testing depends on many factors; Practice D 3740 provides a means of evaluating some of those factors.

6. Apparatus

6.1

6.1 Loading Machine—The loading machine shall be equipped with a movable head or base that travels at a uniform (not pulsating) rate of 0.05 in. (1.27 mm)/min for use in forcing the penetration piston into the specimen. The machine shall be equipped with a load-indicating device that can be read to 10 lbf (44 N) or less. load rate of 0.05 in. (1.27 mm)/min shall be maintained within ±20% over the range of loads developed during penetration. The minimum capacity of the loading machine shall be based on the requirements indicated in Table 1.

TABLE 1 Minimum Load Capacity

Maximum Measurable CBR	Minimum Load Capacity	
	(lbf)	(kN)
20	2500	11.2
50	5000	22.3
>50	10 000	44.5

5.2

6.1.1 The machine shall be equipped with a load-indicating device matched to the anticipated maximum penetration load: 10 lbf (44 N) or less for a 10-kip (44.5-kN) capacity; 5 lbf (22 N) for 5-kip (22.3-kN) and 2 lbf (8.9 N) for 2.5-kip (11.2-kN).

6.1.2 Penetration measuring device (such as a mechanical dial indicator or electronic displacement transducer) that can be read to the nearest 0.001 in. (0.025 mm) and associated mounting hardware. A mounting assembly that connects the deformation measuring device to the penetrating piston and the edge of the mold will give accurate penetration measurements. However, mounting the deformation holder assembly to a stressed component of the load frame (such as tie rods) will introduce inaccuracies of penetration measurements.

6.2 *Mold*—The mold shall be a rigid metal cylinder with an inside diameter of 6 ± 0.026 in. (152.4 ± 0.66 mm) and a height of 7 ± 0.018 in. (177.8 ± 0.46 mm). It shall be provided with a metal extension collar at least 2.0 in. (50.8 mm) in height and a metal base plate having at least twenty eight $\frac{1}{16}$ -in. (1.59-mm) diameter holes uniformly spaced over the plate within the inside circumference of the mold. When assembled with spacer disc in place in the bottom of the mold, the mold shall have an internal volume (excluding extension collar) of 0.075 ± 0.0009 ft³ (2124 ± 25 cm³). Fig. 1 shows a satisfactory mold design. A calibration procedure should be used to confirm the actual volume of the mold with the spacer disk inserted. Suitable calibration procedures are contained in Test Methods D 698 and D 1557.

5.3

6.3 *Spacer Disk*—A circular metal spacer disc (see Fig. 1) having a minimum outside diameter of $5\frac{15}{16}$ in. (150.8 mm) but no greater than will allow the spacer disc to easily slip into the mold. The spacer disc shall be 2.416 ± 0.005 in. (61.37 ± 0.127 mm) in height.

5.4

6.4 *Rammer*—A rammer as specified in either Test Methods D 698 or D 1557 except that if a mechanical rammer is used it must be equipped with a circular foot, and when so equipped, must provide a means for distributing the rammer blows uniformly over the surface of the soil when compacting in a 6-in. (152.4-mm) diameter mold. The mechanical rammer must be calibrated and adjusted in accordance with Test Methods D 2168.

5.5

6.5 *Expansion-Measuring Apparatus*— An adjustable metal stem and perforated metal plate, similar in configuration to that shown in Fig. 1. The perforated plate shall be $5\frac{7}{8}$ to $5\frac{15}{16}$ in. (149.23 to 150.81 mm) in diameter and have at least forty-two $\frac{1}{16}$ -in. (1.59-mm) diameter holes uniformly spaced over the plate. A metal tripod to support the dial gage for measuring the amount of swell during soaking is also required.

TABLE 2 Metric Equivalents

Inch-Pound Units, in.	Metric Equivalent, mm	Inch-Pound Units, in.	Metric Equivalent, mm	Inch-Pound Units, in.	Metric Equivalent, mm
0.003	0.076	$\frac{19}{32}$	15.08	$3\frac{1}{2}$	88.90
0.005	0.127	$\frac{5}{8}$	15.88	$3\frac{3}{4}$	95.25
0.135	3.43	$\frac{3}{4}$	19.10	$4\frac{1}{4}$	108.0
0.201	5.11	$\frac{15}{16}$	23.81	$4\frac{1}{2}$	114.3
0.4375	11.11	1	25.40	$4\frac{3}{4}$	120.7
0.4378	11.12	$1\frac{1}{8}$	28.58	$5\frac{7}{8}$	149.2
0.510	12.95	$1\frac{1}{4}$	31.8	$5\frac{15}{16}$	150.8
0.633	16.08	$1\frac{1}{8}$	34.9	6	152.0
1.370	34.60	$1\frac{1}{2}$	38.10	$6\frac{7}{32}$	158.0
1.375	34.93	$1\frac{3}{4}$	44.5	$6\frac{1}{2}$	165.1
1.954	49.63	$1\frac{15}{16}$	46.04	7	177.8
2.416	61.37	$1\frac{15}{16}$	49.21	$7\frac{1}{2}$	190.1
$\frac{1}{16}$	1.59	2	50.80	$8\frac{3}{8}$	212.7
$\frac{7}{32}$	5.56	$2\frac{1}{8}$	53.98	$8\frac{1}{2}$	215.9
$\frac{1}{4}$	6.35	$2\frac{1}{8}$	55.9	$9\frac{3}{8}$	238.1
$\frac{3}{8}$	9.53	$2\frac{1}{4}$	57.2	$14\frac{1}{4}$	362.0
$\frac{7}{16}$	11.11	$2\frac{1}{2}$	63.50	18	457.2
$\frac{15}{32}$	11.91	$2\frac{3}{4}$	69.85	$32\frac{1}{4}$	719.2
$\frac{1}{2}$	12.70	$2\frac{31}{32}$	75.41	$36\frac{5}{8}$	930.3
$\frac{17}{32}$	13.49	3	76.20	39	990.6

Inch-Pound Units, lb	Metric Equivalent, kg	Inch-Pound Units, psi	Metric Equivalent, MPa
0.04	0.02	200	1.4
0.05	0.02	400	2.8
0.12	0.05	600	4.1
0.59	0.27	800	5.5
0.71	0.32	1000	6.9
0.75	0.34	1200	8.3
3.20	1.45	1400	9.7
5.00	2.27		
10.00	4.54		

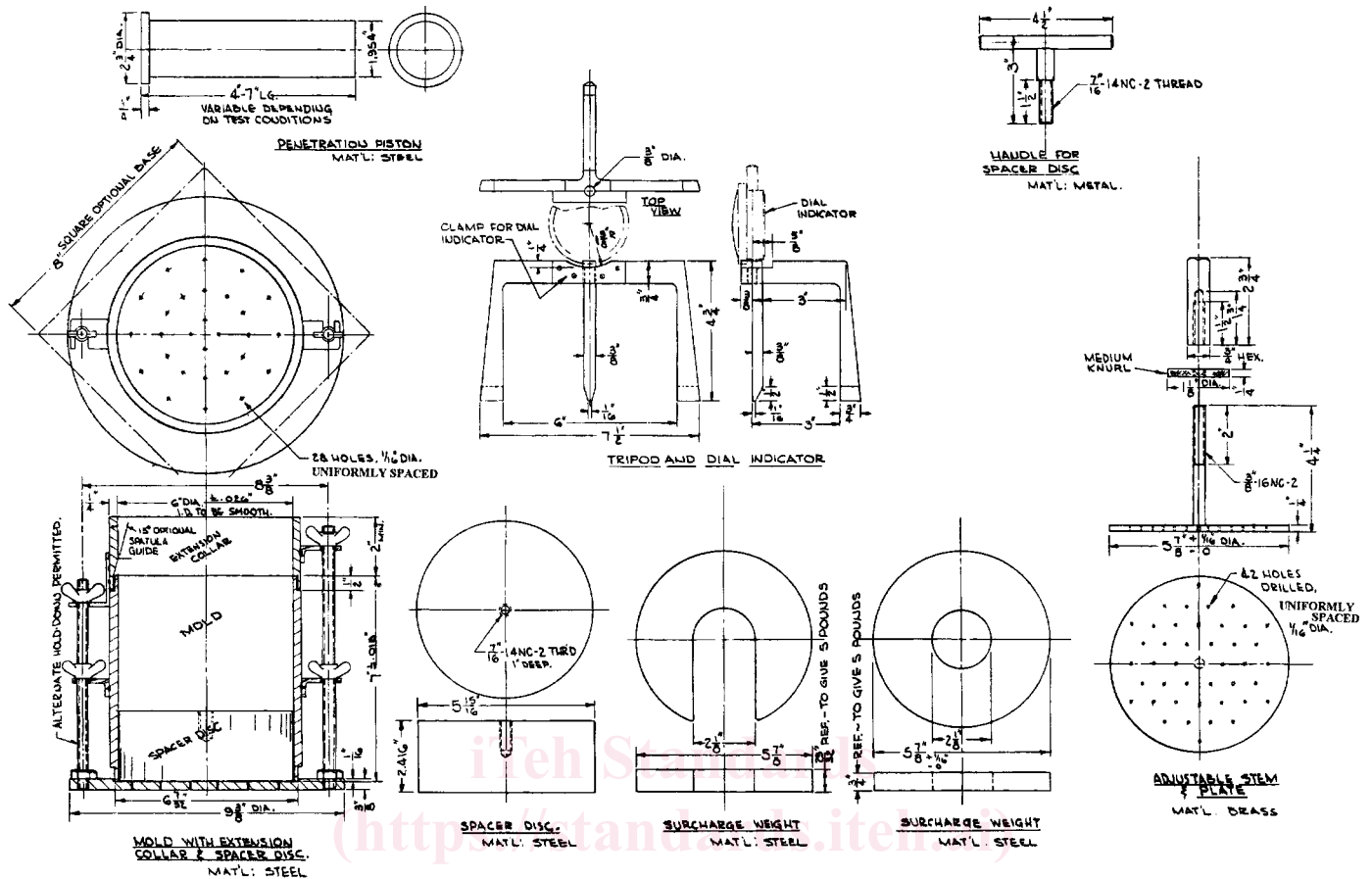

NOTE 1—See Table 2 for metric equivalents.

FIG. 1 Bearing Ratio Test Apparatus

5.6-in. (1.59-mm) diameter holes uniformly spaced over the plate. A metal tripod to support the dial gauge for measuring the amount of swell during soaking is also required. The expansion measuring apparatus shall not weigh more than 2.8 lbf (1.27 kg).

6.6 Weights—One or two annular metal weights having a total mass of 4.54 ± 0.02 kg and slotted metal weights each having masses of 2.27 ± 0.02 kg. The annular weight shall be $5\frac{7}{8}$ to $5\frac{15}{16}$ in. (149.23 to 150.81 mm) in diameter and shall have a center hole of approximately $2\frac{1}{8}$ in. (53.98 mm).

5.7

6.7 Penetration Piston—A metal piston 1.954 ± 0.005 in. (49.63 ± 0.13 mm) in diameter and not less than 4 in. (101.6 mm) long (see Fig. 1). If, from an operational standpoint, it is advantageous to use a piston of greater length, the longer piston may be used.

5.8 Gages—Two dial gages reading to 0.001 in. (0.025 mm) with a range of 0.200 minimum.

5.9 Miscellaneous Apparatus—Other general apparatus such as a mixing bowl, straightedge, scales, soaking tank or pan, oven, fast filtering high wet strength filter paper, dishes, and 2-in., $\frac{3}{4}$ -in. and No. 4 sieves.

6.

6.8 Swell Measurement Device—Generally mechanical dial indicators capable of reading to 0.001 in. (0.025 mm) with a range of 0.200-in. (5-mm) minimum.

6.9 Balance—A class GP5 balance meeting the requirements of Specifications D 4753 for a balance of 1-g readability.

6.10 Drying Oven—Thermostatically controlled, preferably of a forced-draft type and capable of maintaining a uniform temperature of $230 \pm 9^\circ\text{F}$ ($110 \pm 5^\circ\text{C}$) throughout the drying chamber.

6.11 Sieves— $\frac{3}{4}$ in. (19 mm) and No. 4 (4.75 mm), conforming to the requirements of Specification E 11.

6.12 Filter Paper—Fast filtering, high wet strength filter paper, 15-cm diameter.

6.13 Straightedge—A stiff metal straightedge of any convenient length but not less than 10 in. (254 mm). The total length of the straightedge shall be machined straight to a tolerance of ± 0.005 in. (± 0.1 mm). The scraping edge shall be beveled if it is thicker than $\frac{1}{8}$ in. (3 mm).

6.14 Soaking Tank or Pan—A tank or pan of sufficient depth and breadth to allow free water around and over the assembled mold. The tank or pan should have a bottom grating that allows free access of water to the perforations in the mold's base.

6.15 *Mixing Tools*—Miscellaneous tools such as mixing pan, spoon, trowel, spatula, etc., or a suitable mechanical device for thoroughly mixing the sample of soil with water.

7. Sample

6.1.1 The specimen(s) for compaction shall be prepared in accordance with the procedures given in Method C of Test Methods D 698 or D 1557 for compaction in a 6-in. (152.4-mm) mold except as follows:

6.1.1.1 If all material passes a $\frac{3}{4}$ -in. (19-mm) sieve, the entire gradation shall be used for preparing specimens for compaction without modification. If material is retained on the $\frac{3}{4}$ -in. (19-mm) sieve, the material retained on the $\frac{3}{4}$ -in. (19-mm) sieve shall be removed and replaced by an equal amount¹ mass of material passing the $\frac{3}{4}$ -in. (19-mm) sieve and retained on the No. 4 sieve obtained by separation from portions of the sample not used for testing.

7.

8. Test Specimens

7.1

8.1 *Bearing Ratio at Optimum Water Content Only*—Using material prepared as described in 6.1.1, conduct a control compaction test with a sufficient number of test specimens to establish the optimum water content for the soil using the compaction method specified, either Test Methods D 698 or D 1557. A previously performed compaction test on the same material may be substituted for the compaction test just described, provided that if the sample contains material retained on the $\frac{3}{4}$ -in. (19-mm) sieve, soil prepared as described in 6.1.1 is used (Note 1²).

NOTE 2—Maximum dry unit weight obtained from a compaction test performed in a 4-in. (101.6-mm) diameter mold may be slightly greater than the maximum dry unit weight obtained from compaction in the 6-in. (152.4-mm) compaction mold or CBR mold.

7.1.1.1 For cases where the CBR is desired at 100 % maximum dry unit weight and optimum water content, compact a specimen using the specified compaction procedure, either Test Methods D 698 or D 1557, from soil prepared to within ± 0.5 percentage point of optimum water content determined in accordance with Test Method D 2216.

NOTE 3—Where the maximum dry unit weight was determined from compaction in the 4-in. (101.6-mm) mold, it may be necessary to compact specimens as described in 7.1.1.2, using 75 blows per layer or some other value sufficient to produce a specimen having a density equal to or greater than that required.

7.1.2

8.1.2 Where the CBR is desired at optimum water content and some percentage of maximum dry unit weight, compact three specimens from soil prepared to within ± 0.5 percentage point of optimum water content and using the specified compaction but using a different number of blows per layer for each specimen. The number of blows per layer shall be varied as necessary to prepare specimens having unit weights above and below the desired value. Typically, if the CBR for soil at 95 % of maximum dry unit weight is desired, specimens compacted using 56, 25, and 10 blows per layer is satisfactory. Penetration shall be performed on each of these specimens.

7.2

8.2 *Bearing Ratio for a Range of Water Contents*—Prepare specimens in a manner similar to that described in 7.1.1 except that each specimen used to develop the compaction curve shall be penetrated. In addition, the complete water content-unit weight relationship for the 25-blow and 10-blow per layer compactions shall be developed and each test specimen compacted shall be penetrated. Perform all compaction in the CBR mold. In cases where the specified unit weight is at or near 100 % maximum dry unit weight, it will be necessary to include a compactive effort greater than 56-blows per layer (Note 3).

NOTE 4—A semilog log plot of dry unit weight versus compactive effort usually gives a straight line relationship when compactive effort in ft-lb/ft³ is plotted on the log scale. This type of plot is useful in establishing the compactive effort and number of blows per layer needed to bracket the specified dry unit weight and water content range.

7.2.1 If the sample is to be soaked, take a representative sample of the material, for the determination of water content, at the beginning of compaction and another sample of the remaining material after compaction. Use Test Method D 2216 to determine the water content. If the sample is not to be soaked, take a water content sample in accordance with Test Methods D 698 or D 1557

8.2.1 If the CBR test specimen is to be soaked, take a representative sample of the material for the determination of water content in accordance with Test Method D 2216. If the compaction process is conducted under reasonable controlled temperatures (65 to 75 F (18 to 24 C) and the processed soil is kept sealed during the compaction process, only one representative water content sample is required. However if the compaction process is being conducted in an uncontrolled environment take two water content samples one at the beginning of compaction and another sample of the remaining material after compaction. Use Test Method D 2216 to determine the water contents and average the two values for reporting. The two samples should not differ more than 1.5 percentage points to assume reasonable uniformity of the compacted specimen's water content.

8.2.2 If the sample is not to be soaked, take a water content sample in accordance with Test Methods D 698 or D 1557 if the average water content is desired.

7.2.2 8.2.3 Clamp the mold (with extension collar attached) to the base plate with the hole for the extraction handle facing down. Insert the spacer disk over the base plate and place a disk of filter paper on top of the spacer disk. Compact the soil-water