



Standard Specification for Crosslinked Polyethylene/Aluminum/Crosslinked Polyethylene Tubing OD Controlled SDR⁹¹

This standard is issued under the fixed designation F2262; the number immediately following the designation indicates the year of original adoption or, in the case of revision, the year of last revision. A number in parentheses indicates the year of last reapproval. A superscript epsilon (ϵ) indicates an editorial change since the last revision or reapproval.

1. Scope

1.1 This specification covers establishes requirements for coextruded crosslinked polyethylene multi-layer pressure tubing with a continuously welded aluminum tube construction between inner and outer layers of plastic. The inner and outer crosslinked polyethylene layers are bonded to the aluminum by a melt adhesive. The tubing is outside diameter controlled and made in one standard dimension ratio, SDR9 and is intended to be used for hot and cold water conveyance in applications up to 180°F (82.2°C). Included in this specification is a system of nomenclature for crosslinked polyethylene-aluminum-crosslinked polyethylene (PEX-AL-PEX) tubes, and the requirements and test methods for materials, dimensions of component layers and the finished tubing, layer adhesion test, weld strength, short-term burst pressure, long-term sustained pressure and marking requirements. The tubing covered by this specification is intended for use in potable water distribution systems for residential and commercial applications, water service, hydronic radiant heating (HRH), radiant panel heating, baseboard, and snow melt systems.

1.2 This specification covers only plastic-metal-plastic multi-layer tubes incorporating a continuous welded aluminum tube. Tubing consisting of metallic layers not welded together is outside the scope of this specification.

1.3 *Units*—The values stated in inch-pound units are to be regarded as standard. The values given in parentheses are mathematical conversions to SI units that are provided for information only and are not considered standard.

1.4 Specifications for connectors for use with pipe meeting the requirements of this specification are given in **Annex A1**.

1.5 The following precautionary caveat pertains only to the test method portion, Section 9, of this specification. *This standard does not purport to address all of the safety concerns, if any, associated with its use. It is the responsibility of the user*

of this standard to establish appropriate safety and health practices and determine the applicability of regulatory requirements prior to use.

2. Referenced Documents

2.1 ASTM Standards:²

- D618 Practice for Conditioning Plastics for Testing
- D883 Terminology Relating to Plastics
- D1598 Test Method for Time-to-Failure of Plastic Pipe Under Constant Internal Pressure
- D1599 Test Method for Resistance to Short-Time Hydraulic Pressure of Plastic Pipe, Tubing, and Fittings
- D1600 Terminology for Abbreviated Terms Relating to Plastics
- D2122 Test Method for Determining Dimensions of Thermoplastic Pipe and Fittings
- D2765 Test Methods for Determination of Gel Content and Swell Ratio of Crosslinked Ethylene Plastics
- D3350 Specification for Polyethylene Plastics Pipe and Fittings Materials
- F412 Terminology Relating to Plastic Piping Systems

2.2 NSF International Standards:

- NSF/ANSI 14 for Plastic Piping Components and Related Materials³
- NSF/ANSI 61 for Drinking Water System Components-Health Effects³

2.3 Federal Standard:

- Fed. Std. No. 123 Marking for Shipments (Civil Agencies)⁴

2.4 Military Standard:

- MIL-STD-129 Marking for Shipment and Storage⁴

2.5 Uniform Classification and Committee Standard: Uniform Freight Classification⁵

² For referenced ASTM standards, visit the ASTM website, www.astm.org, or contact ASTM Customer Service at service@astm.org. For *Annual Book of ASTM Standards* volume information, refer to the standard's Document Summary page on the ASTM website.

³ Available from NSF International, P.O. Box 130140, 789 N. Dixboro Rd., Ann Arbor, MI 48113-0140, <http://www.nsf.org>.

⁴ Available from Standardization Documents Order Desk, DODSSP, Bldg. 4, Section D, 700 Robbins Ave., Philadelphia, PA 19111-5098, <http://www.dodssp.daps.mil>.

⁵ Available from the Uniform Classification Committee, Suite 1106, 222 South Riverside Plaza, Chicago, IL 60606.

¹ This specification is under the jurisdiction of ASTM Committee F17 on Plastic Piping Systems and is the direct responsibility of Subcommittee F17.11 on Composite.

Current edition approved May 1, 2009. Published May 2009. Originally approved in 2003. Last previous edition approved in 2005 as F2262 – 05. DOI: 10.1520/F2262-09.

TABLE 1 Outside Diameters, Tolerances, and Aluminum Thickness for PEX-AL-PEX

Nominal Tubing Size, in.	Average Outside Diameter, in. (mm)	Tolerance on Avg, in. (mm)	Maximum Out-of-Roundness, in. (mm)	Aluminum Thickness Minimum, in. (mm)
1/2	0.625 (15.88)	± 0.004 (0.10)	0.010 (0.25)	0.0095 (0.24)
3/4	0.875 (22.22)	± 0.004 (0.10)	0.010 (0.25)	0.0115 (0.29)
1	1.125 (28.58)	± 0.005 (0.12)	0.010 (0.25)	0.0115 (0.29)

TABLE 2 Wall Thickness for PEX-AL-PEX

Nominal Tubing Size, in.	Total Wall Thickness, min, in. (mm)	Tolerance on Total Wall, in. (mm)	Outer PEX Layer Thickness min, in. (mm)	Inner PEX Layer Thickness min, in. (mm)
1/2	0.070 (1.78)	+ 0.010 (0.25)	0.010 (0.25)	0.043 (1.09)
3/4	0.097 (2.47)	+ 0.010 (0.25)	0.010 (0.25)	0.069 (1.75)
1	0.125 (3.18)	+ 0.013 (0.33)	0.010 (0.25)	0.097 (2.46)

2.6 *National Motor Freight Traffic Association Standard: National Motor Freight Classification*⁶

3. Terminology

3.1 Definitions are in accordance with Terminology **F412** and abbreviations are in accordance with Terminology **D1600**, unless otherwise indicated.

3.2 *Definitions of Terms Specific to This Standard:*

3.2.1 *tubing, PEX-AL-PEX, n*—multi-layer tubing produced by coextrusion or extrusion of layers of polyethylene/aluminum/ polyethylene bonded together with a melt adhesive and crosslinked by irradiation or chemical means in combination with applied heat and moisture, or any combination thereof.

3.2.2 *tubing hoop stress, n*— a value of hoop stress based on the assumption of a homogeneous wall cross-section.

3.2.2.1 *Discussion*—Thick walled plastic tubes produced from one material have hoop stresses that vary through the wall thickness, and are usually described by the Lamé Theory. The multi-layer nature of PEX-AL-PEX tubing, composed of materials with very different Young’s Modulus values, will, on pressurization, not have uniform stress distribution through the thickness of the wall of the tube. PEX-AL-PEX tubes have a hoop stress distribution that differs substantially from both thick and thin walled tubing cases.

3.2.3 *unaided eye, n*—observable without visual enhancement beyond correction for normal vision.

4. Classification

4.1 *General*—This specification covers one type of PEX-AL-PEX tubing with outside diameters corresponding to the outside diameter of the same nominal size as copper tubing (CTS).

4.2 *Tubing Outside Diameter*—The PEX-AL-PEX tubes specified in this standard are classified by the outside diameter in one standard dimension ratio, SDR9.

5. Materials

5.1 *General*—PEX-AL-PEX tubing is comprised of one metallic layer, two layers of polymeric adhesive and two-layers

of crosslinked polyethylene. For tubing made to this specification, the constituent materials shall meet the respective requirements of **5.2 – 5.5**.

5.2 *Aluminum*—The aluminum shall have a minimum thickness as specified in **Table 1**. The material shall have a minimum elongation and tensile strength of 20 % and 13 000 psi (90 MPa), respectively. The tests for these properties shall be conducted in accordance with ASTM E8.

5.3 *Crosslinked Polyethylene:*

5.3.1 Polyethylene plastics used to make the PEX layers of the PEX-AL-PEX tubing shall be virgin resin having a minimum density of 0.941 g/cm³. The outer layer of polyethylene shall be of color code B, C, or E in accordance with Specification **D3350**. Color code B compounds shall have sufficient ultraviolet (UV) stabilization to protect the tubing from deleterious effects due to outdoor exposure during storage and shipping. The inner layer of polyethylene shall be of color code A, B, or C.

5.3.2 The polyethylene, in the final finished state in the tubing, shall be crosslinked as defined in Terminology **D883**. The polyethylene layers may be crosslinked by peroxides, Azo compounds, or silane compounds in extrusion, or by electron beam irradiation after extrusion, or by other means such that the tubing meets the performance requirements of Section 6.

5.4 *Melt Adhesive*—The material shall have a density cell of 1, 2, or 3; a melt index cell of 1, 2, or 3; and a color code of A or B, in accordance with Specification **D3350**.

5.5 *Rework Material*—The use of reclaimed, recycled, or re-work plastics is not permitted.

6. Requirements

6.1 *General*—The requirements and test methods in this specification cover PEX-AL-PEX tubing. Tests on the individual layers that comprise the final multi-layer tubing are outside the scope of this specification. The raw materials used, however, shall conform to the requirements of Section 5.

6.2 *Dimensions and Tolerances:*

6.2.1 The dimensions of the tubing and layers shall be in accordance with **Tables 1 and 2** when measured in accordance with **9.1**.

6.2.1.1 *Out-of-Roundness*—Maximum out-of-roundness tolerances apply only to measurements made on pipe prior to coiling.

⁶ Available from National Motor Freight Traffic Association (NMFTA), 1001 N. Fairfax St., Alexandria, VA 22314, <http://www.nmfta.org>.

6.2.1.2 *Pipe Wall Thickness*—The minimum wall thickness at any point of measurement around the pipe circumference shall not be less than the value specified in Table 2.

6.2.1.3 *Outer and Inner PEX Layer Thickness*—The thickness of the PEX layers shall have a minimum value and tolerance as specified in Table 2, except for the polyethylene material overlaying the weld, which shall allow half the minimum specified in Table 2.

6.3 *Adhesion*—There shall be no visible delamination or separation of the PEX and aluminum layers, either on the bore side or the outside (see Fig. 1), when examined with the unaided eye in accordance with 9.2.

6.4 *Burst Pressure*—Tubing shall meet or exceed the minimum burst pressure requirements shown in Table 3 when tested in accordance with 9.3.

NOTE 1—*Burst pressure testing*, is intended to be a test which can detect mechanical and material flaws from the construction of the tube. Minimum Burst pressure requirements are generally selected based upon the mechanical strength properties of the materials of construction at the specific temperatures to be tested without regard to the ductile characteristics of the polymer.

6.5 *Sustained Pressure*—Tubing shall not fail, balloon, burst, or weep, as defined in Test Method D1598 when tested

for 1000 h at the temperature and pressure listed in Table 3 when tested in accordance with 9.4.

NOTE 2—*Sustained pressure testing*, in thermoplastic pipe and tubing standards relates generally to a short-term validation of the long-term hydrostatic properties that have been previously determined by a minimum of 10 000 h of hydrostatic testing. Generally the sustained hydrostatic pressure selected for the shorter term testing is based upon a lower hoop stress selection than one which would otherwise be expected to generate a rupture failure.

6.6 *Gel Content*—The inner and outer layers of crosslinked polyethylene, when tested in accordance with 9.5, shall be within the range from 65 to 89 % inclusive. Depending on the process used, the following minimum percentage crosslinking values shall be achieved: 70 % by peroxides, 65 % by Azo compounds, 65 % by electron beam, or 65 % by silane compounds.

6.7 *Apparent Ring Tensile Strength*—The pipe rings, when tested in accordance with 9.6, shall meet the minimum strength specifications defined in Table 4.

7. Workmanship, Finish, and Appearance

7.1 The tubing shall be free of visible cracks, blisters, holes, foreign inclusions and other known injurious defects. The

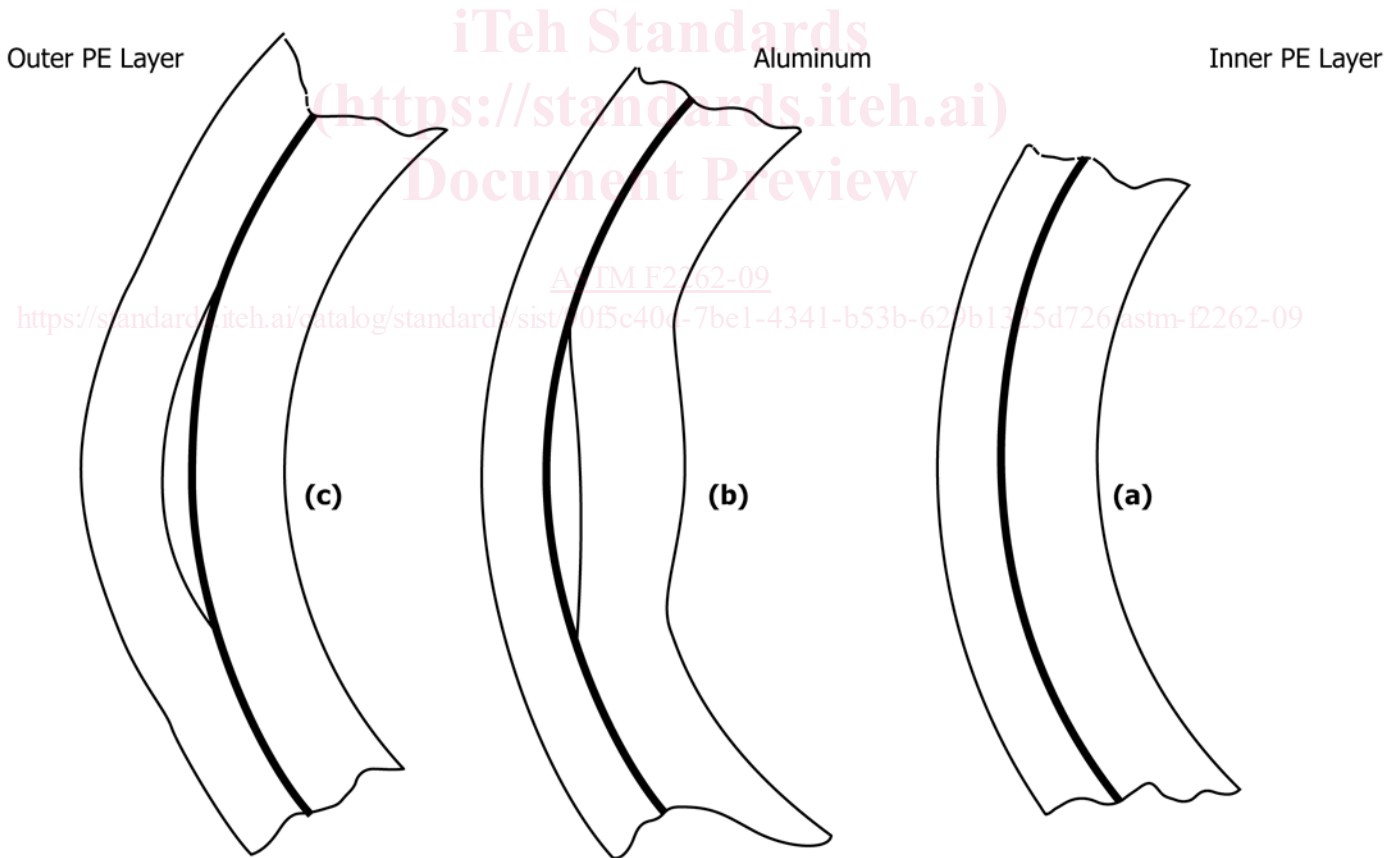

- (a) Good pipe showing no delamination.
- (b) Delamination between the inner layer and the aluminum.
- (c) Delamination between the outer layer and the aluminum.

FIG. 1 Detection of Delamination

TABLE 3 Minimum Burst Pressure and Sustained Pressure Requirements

Nominal Tubing Size, in.	Minimum Burst Pressure at 73°F (23°C), psi (kPa)	Minimum Burst Pressure at 180°F (82°C), psi (kPa)	Sustained Pressure Requirement at 180°F (82.2°C), psi (kPa)
1/2	880 (6000)	580 (4000)	320 (2205)
3/4	770 (5310)	465 (3200)	320 (2205)
1	685 (4720)	400 (2760)	320 (2205)

TABLE 4 Minimum Ring Tensile Strengths

Nominal Tubing Size, in.	Minimum Ring Tensile Strength, lb (N)
1/2	410 (1820)
3/4	410 (1820)
1	500 (2200)

tubing shall be as uniform as practical in color, opacity, density and other physical properties.

8. Sampling and Conditioning

8.1 Sampling—Collect a sample of the PEX-AL-PEX tubing sufficient to determine conformance with this specification.

8.2 Conditioning:

8.2.1 For referee purposes, condition the specimens at 73.4 ± 3.6°F (23 ± 2°C) and 50 ± 5 % relative humidity for not less than 40 h prior to testing in accordance with Procedure A of Practice D618, for those tests where conditioning is required. In cases of disagreement, the tolerances shall be ± 1.8°F (± 1°C) and ± 2 % relative humidity.

8.2.2 For routine quality control testing, condition the specimens at the temperature and humidity of the manufacturers testing facility for not less than 1 h or until the specimens are at the room temperature.

8.3 Test Conditions:

8.3.1 For referee purposes, conduct the tests in the standard laboratory atmosphere of 73.4 ± 3.6°F (23 ± 2°C) and 50 ± 5 % relative humidity, unless otherwise specified. In cases of disagreement, the tolerances shall be ± 1.8°F (± 1°C) and ± 2 % relative humidity.

8.3.2 For routine control testing, conduct tests at the room temperature and humidity of the manufacturers testing area.

9. Test Methods

9.1 Dimensions:

9.1.1 Any length of tubing selected at random is suitable to determine dimensions.

9.1.2 Outside Diameter—Measure the outside diameter of tubing in accordance with Test Method D2122.

9.1.3 Total Wall Thickness—Make measurements of the total wall thickness in accordance with Test Method D2122. Measure the total wall thickness at each end of the sample to the nearest 0.001 in (0.02 mm).

9.1.4 Inner and Outer Crosslinked Polyethylene Layer Thickness:

9.1.4.1 Sample Preparation—Cut the tubing with a suitable sharp cutter ensuring that the tubing at the point of the cut and after cutting is no more than 10 % out-of-round.

9.1.4.2 Thickness Determination—Using a visual magnifying instrument with sufficient magnification to render a measuring resolution of 0.001 in. (0.02 mm) with a graduated reticle, measure the thickness of both inner and outer layers at six equally spaced points around the circumference.

9.2 Adhesion Examination:

9.2.1 Cutting the Spiral—Mount a Stanley 1991 or similarly sharp but rigid, razor-like blade within a protective housing and angle to cut a 45 ± 5° spiral in a pipe sample (see Fig. 2). Choose a PEX-AL-PEX tubing sample at random and insert into the housing and rotate to form the spiral cut. The cut goes through the complete wall on one side of the pipe only. Run the spiral along the pipe for a minimum distance along the pipe axis equal to five times the outside diameter.

9.2.2 Examining for Delamination—Firmly hold the tubing, cut as in 9.3.1, at the uncut end and create a ribbon of material by opening out the spiral-cut. Pliers can be used to grip the cut tubing. Visually examine the wall of the tubing side-on for evidence of delamination between the metal and plastic layers (see Fig. 1)

9.3 Burst Pressure:

9.3.1 Samples—Prepare five conditioned samples 12 ± 0.5 in (305 ± 13 mm) in length cut consecutively from a single length of tubing and seal the ends with appropriate connections or end caps as required. For testing in air, condition the samples at the test temperature for 4 h prior to pressurization. When burst tests are to be conducted in a water bath, condition the samples in the water bath for 1 h prior to testing.

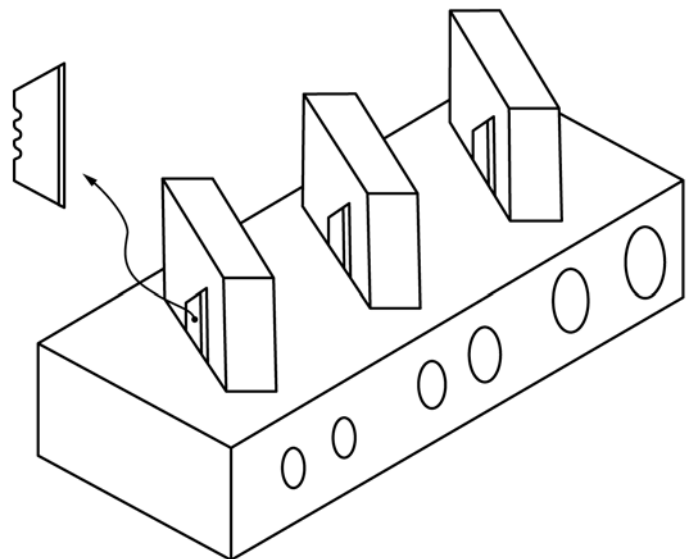

FIG. 2 Spiral Cutter for the Delamination Test

9.3.2 *Burst Pressure*—Determine the burst pressure for each sample in accordance with the procedure in Test Method **D1599**. The test temperatures and minimum burst pressure values are given in **Table 3**.

9.4 *Sustained Pressure Test:*

9.4.1 *Samples*—Prepare six conditioned samples of each size to be tested. Each test sample shall have a minimum length between end closures of 10 times the nominal outside diameter but not less than 12 in. (305 mm). Seal the ends of samples with appropriate connections or end caps and fill the samples with water.

9.4.2 *Temperatures*—The test temperature shall be $180 \pm 3.6^\circ\text{F}$ ($82 \pm 2^\circ\text{C}$). The external test environment is water or air.

9.4.3 *Conditioning*—For testing in a water bath, condition the samples for a minimum of 2 h at the test temperature prior to pressurization. For testing in air, condition the samples at the test temperature for 4 h prior to pressurization. Maintain the test pressure ± 10 psi (± 70 kPa) for the duration of the test.

9.4.4 *Test Procedure*—After the appropriate conditioning period, raise the internal pressure to the test pressure specified in **Table 3** ± 10 psi (± 69 kPa). Maintain this pressure for a period of 1 000 h.

9.4.5 *Failure*—Any continuous loss of pressure of the test sample shall constitute failure of this test. Failure of one of the six samples is cause for retest of six additional samples. Failure of one of six of the retested samples constitutes failure of this test.

9.5 *Gel Content Determination:*

9.5.1 *Sample Preparation*—Condition the PEX-AL-PEX pipe in a water bath for a minimum of 24 h at a minimum temperature of 176°F (80°C) prior to testing to ensure full crosslinking of the resin. Before removing strands for gel content evaluation, put pipe in air circulating oven at 248°F (120°C) for 20 min. Remove 0.004 in. (0.1 mm) thick strands from both inner and outer layers, long enough to obtain a 0.3 g sample for testing. Take care to not cut into adhesive layer, as this will adversely affect the test results. (See **Note 3**.)

NOTE 3—Inclusion of adhesive in the test specimen will lower the gel content resulting in a false reading.

9.5.2 *Testing Method*—Test the sample from the inner and outer surface separately and in accordance with Test Method **D2765**, Sections 12 and 13, using Test Method A.

9.6 *Ring Tensile Strength Test:*

9.6.1 *Sample Size and Shape*—Cut rings of the PEX-AL-PEX tubing so that the two sides are parallel and at $90 \pm 2^\circ$ to the tubing axis. The width of each ring shall be 1 ± 0.04 in. (25 ± 1.0 mm). Cut a minimum of 15 samples consecutively along the axis of the tubing.

9.6.2 *Ring Tensile Test*—Test the 15 samples using a tensile testing machine, arranging the rings so that the aluminum weld is at 90° to the tensile axis as shown in **Fig. 3**. The crosshead speed shall be 2 ± 0.1 in./min (50 ± 2.5 mm/min.). Mount the rings of tubing on two steel rods of minimum diameter of 0.16 in. (4 mm). Record the peak force.

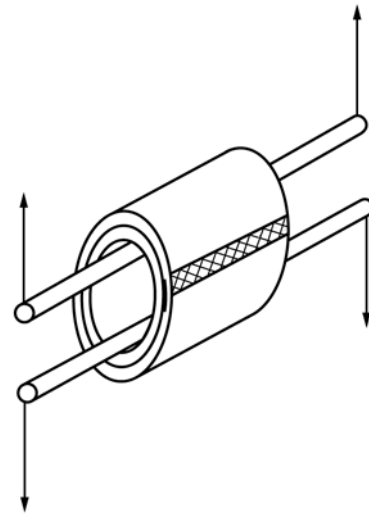

FIG. 3 Schematic Presentation of the Pipe Ring Test Showing the Aluminum Weld at 90° to the Tensile Axis

10. Retest and Rejection

10.1 If any failure occurs, a retest shall be conducted only if agreed upon between the purchaser and the seller. Under such agreement, minimum requirements shall not be lowered, changed, or modified, nor shall specification limits be changed. Failure in the retest is cause for rejection of the shipment.

11. Marking

11.1 *Quality of Marking*—The marking shall be applied to the tubing in such a manner that it remains legible after installation and inspection.

11.2 *Content*—Markings on the tubing shall include the following, spaced at intervals of not more than 5 ft (1.5 m):

11.2.1 Nominal tubing size (for example, $\frac{1}{2}$ in.).

11.2.2 Standard Dimension ratio, SDR9.

11.2.3 The material designation, “PEX-AL-PEX.”

11.2.4 Pressure rating(s) for water and the temperature(s) for which the rating(s) is (are) valid.

11.2.5 ASTM designation D2262, with which the tubing complies.

11.2.6 Manufacturer's name or trademark, or both, and production code.

11.2.7 Tubing intended for the transport of potable water shall also include the seal or mark of the laboratory making the evaluation for this purpose, spaced at intervals specified by the laboratory.

12. Quality Assurance

12.1 When the product is marked with the ASTM designation F2262, the manufacturer affirms that the product was manufactured, inspected, sampled, and tested in accordance with this specification and has been found to meet the requirements of this specification. When specified in the purchase order or contract, a report of the test results shall be furnished.

13. Keywords

13.1 crosslinked PE; multi-layer; PEX-AL-PEX; pressure; tubing

SUPPLEMENTARY REQUIREMENTS

POTABLE WATER REQUIREMENT

This requirement applies whenever a regulatory authority or user calls for product to be used to convey or be in contact with potable water.

S1. *Potable Water Requirements*

S1.1 Products intended for the transport of potable water shall be evaluated, tested and certified for conformance with NSF/ANSI 61 or the health effects portion of NSF/ANSI 14 by

an acceptable certifying organization when required by the regulatory authority having jurisdiction.

GOVERNMENT MILITARY PROCUREMENT

These requirements apply only to Federal/Military procurement, not domestic sales or transfers.

S2. *Responsibility for Inspection*

S2.1 Unless otherwise specified in the contract or purchase order, the producer is responsible for the performance of all inspection and test requirements specified herein. The producer may use his own or any other suitable facilities for the performance of the inspection and test requirements specified herein, unless disapproved by the purchaser. The purchaser shall have the right to perform any of the inspections and test set forth in this specification where such inspections are deemed necessary to ensure that the material conforms to the prescribed requirements.

NOTE S2.1—In U.S. federal/military contracts, the contractor is responsible for inspections.

S3. *Packaging and Marking for U.S. Government Procurement*

S3.1 *Packaging*—Unless otherwise specified in the contract, the material shall be packaged in accordance with the supplier's standard practice in a manner ensuring arrival at destination in a satisfactory condition and which will be acceptable to the carrier at lowest rates. Containers and packaging shall comply with Uniform Freight Classification rules or National Motor Freight Classification rules.

S3.2 *Marking*—Marking for shipment shall be in accordance with Fed. Std. No. 123 for civil agencies and MIL-STD-129 for military agencies.

NOTE S3.1—The inclusion of U.S. federal/military procurement requirements should not be construed as an indication that the U.S. federal/military uses or endorses the products described in this specification.

CHLORINE RESISTANCE EVALUATION

The following supplemental requirements shall apply to any product intended to be used in a water system which utilizes residual free chlorine as a disinfecting agent.

S4. *Evaluation Methodology*—Multi-layer (composite) piping shall be tested and evaluated in accordance with S5 for multi-layer products using PEX materials that were tested in a solid-wall form.

S5. *Procedure for Using Data from Solid-wall PEX Testing*—The 95 % lower confidence limit of the multi-layer piping product minimum estimated failure time shall be at least 50 years when evaluated in accordance with S5.1–S5.3 using

conditions of 0.55 MPa (80 psig) internal pressure, 25 % use at 60°C (140°F) and 75 % use at 23°C (73°F).

S5.1 *PEX Material Test*—The PEX material shall be tested in accordance with Test Method F2023 using solid-wall pipe samples.

S5.1.1 The test fluid shall be prepared in accordance with 9.1.1 of F2023.