



**Designation: E661–88(Reapproved 1997) Designation: E 661 – 03 (Reapproved 2009)**

# Standard Test Method for Performance of Wood and Wood-Based Floor and Roof Sheathing Under Concentrated Static and Impact Loads <sup>1</sup>

This standard is issued under the fixed designation E 661; the number immediately following the designation indicates the year of original adoption or, in the case of revision, the year of last revision. A number in parentheses indicates the year of last reapproval. A superscript epsilon ( $\epsilon$ ) indicates an editorial change since the last revision or reapproval.

## INTRODUCTION

During construction and occupancy of a building, floor and roof sheathing are subjected to concentrated loads that frequently govern the thickness required. Static loads may simulate either foot traffic, or loads from fixtures, when applied through loading disks of appropriate size. Impact loads will occur during construction and also in service.

Roof sheathing and subflooring are likely to be critical in strength or stiffness, or both, under foot traffic and construction loads, while single-layer floors are generally critical under fixture loads, foot traffic, and in-service impact loads. Subfloors, like single floors, must also support fixture loads, but they will have an additional layer of material, such as underlayment above, which will help to distribute concentrated loads.

## 1. Scope

1.1 This test method covers procedures for determining the resistance to deflection and damage of floor and roof sheathing used in site-built construction subjected to concentrated static loads as well as impact loads from nonrigid blunt objects. It is applicable to wood and wood-based panels and boards, but is not intended to cover profiled metal decks, nor precast or cast-in-place slabs. Surface indentation is not evaluated separately from deflection.

1.2 Three applications are covered: roof sheathing, subfloors, and single floors. Roof sheathing is tested in both a dry and a wet condition, while subfloors and single floors are both tested in a dry condition, as well as a condition of having dried out after being wet. These moisture conditions are those commonly experienced with site-built construction.

NOTE 1—Where it is anticipated that sheathing will be subjected only to dry conditions during construction and use, or else to greater moisture exposure than is indicated in 6.3.27.3.2, the corresponding exposure conditions may be modified by agreement between the interested parties. For example, shop-built construction may be tested dry only, although the possibility of exposure to high humidity or leaks and flooding during use should be considered.

1.3 The values stated in metric (SI) units are to be regarded as the standard.

1.4 *This standard does not purport to address all of the safety concerns, if any, associated with its use. It is the responsibility of the user of this standard to establish appropriate safety and health practices and determine the applicability of regulatory limitations prior to use.*

## 2. Referenced Documents

2.1 *ASTM Standards:*<sup>2</sup>

D 1517 ~~Definitions of Terms Relating to Leather~~ Terminology Relating to Leather

E 575 ~~Practice for Reporting Data from Structural Tests of Building Constructions, Elements, Connections, and Assemblies~~  
Practice for Reporting Data from Structural Tests of Building Constructions, Elements, Connections, and Assemblies

E 631 ~~Terminology of Building Constructions~~

2.2 *Federal Standards: Other Standards:*

<sup>1</sup> This test method is under the jurisdiction of ASTM Committee E6/E06 on Performance of Buildings and is the direct responsibility of Subcommittee E06.11 on Horizontal and Vertical Structures/Structural Performance of Completed Structures.

Current edition approved May 27, 1988. Published September 1988. Originally published as E661–78. Last previous edition E661–78.

Current edition approved April 1, 2009. Published May 2009. Originally approved in 1978. Last previous edition approved in 2003 as E 661 – 03.

<sup>2</sup> Annual Book of ASTM Standards, Vol 15.04.

<sup>3</sup> For referenced ASTM standards, visit the ASTM website, [www.astm.org](http://www.astm.org), or contact ASTM Customer Service at [service@astm.org](mailto:service@astm.org). For Annual Book of ASTM Standards volume information, refer to the standard's Document Summary page on the ASTM website.

### 3. Summary of Test Method

3.1 Roof and floor sheathing specimens are subjected to concentrated loads applied through a 76-mm (3-in.) or a 25-mm (1-in.) diameter loading disk, depending on the intended use and the properties to be evaluated. They are also subjected to the impact of a shot-filled drop bag. Specimens are tested in a horizontal position, mounted on fully supported framing members and with loads applied to the top surface near an edge, or at a location determined to be more vulnerable. Any support framing may be used that is representative of the anticipated service, as the framing is not considered a major test variable. Terminology

3.1 See Terminology E 631 for terms related to this standard.

### 4. Significance and Use

4.1 The procedures outlined will provide data that can be used to evaluate the structural performance, under concentrated loads, of roof and floor sheathing, separate from the effects of the framing, under simulated conditions representative of those in actual service.

4.2 The procedures are intended to be applied to roof or floor sheathing materials installed directly to framing. They are not intended for the evaluation of the framed assembly as a whole. Summary of Test Method

4.1 Roof and floor sheathing specimens are subjected to concentrated loads applied through a 76-mm (3-in.) or a 25-mm (1-in.) diameter loading disk, depending on the intended use and the properties to be evaluated. They are also subjected to the impact of a shot-filled drop bag. Specimens are tested in a horizontal position, mounted on fully supported framing members and with loads applied to the top surface near an edge, or at a location determined to be more vulnerable. Any support framing may be used that is representative of the anticipated service, as the framing is not considered a major test variable.

### 5. Significance and Use

5.1 The procedures outlined will provide data that can be used to evaluate the structural performance, under concentrated loads, of roof and floor sheathing, separate from the effects of the framing, under simulated conditions representative of those in actual service.

5.2 The procedures are intended to be applied to roof or floor sheathing materials installed directly to framing. They are not intended for the evaluation of the framed assembly as a whole.

### 6. Apparatus

5.1

6.1 Concentrated Load—The apparatus for the concentrated load test shall conform to the following requirements (see Fig. 1):

5.1.1

6.1.1 Supports—The framing members shall be supported in order not to deflect under the applied loads. The support system shall include provisions for rigidly restraining the ends of the framing members, as with blocking and clamps, to prevent rotation or vertical movement during testing.

5.1.2

6.1.2 Loading Device—Any convenient means may be used for applying a compressive load up to ultimate, and for measuring the load within  $\pm 1\%$  accuracy. Load shall be applied through a ball-and-socket joint to assure even application.

5.1.3

6.1.3 Loading Disks—Two steel disks are required, one having a diameter of 25 mm (1 in.), representing a concentrated load, and one of 76 mm (3 in.) representing foot traffic, each with a thickness of at least 13 mm (0.50 in.). The edge of the loading disk contacting the test specimen shall be rounded to a radius not exceeding 1.5 mm (0.06 in.).

5.1.4

6.1.4 Deflection Gage, mounted on a rigid tripod whose legs rest on the sheathing immediately above the framing members that are adjacent to the load point (Fig. 1). The deflection gage should have a range exceeding the maximum anticipated deflection, have a maximum error of  $\pm 1\%$ , and be graduated to 0.02 mm (0.001 in.).

5.2

6.2 Impact Load—The apparatus for the impact load test shall conform to the requirements of 5.1.1-5.1.4, 6.1.1-6.1.4. In addition, the following equipment shall be used:

5.2.1

6.2.1 Drop Bag—The bag shall be constructed as in 5.2.1.1-5.2.1.3-6.2.1.1-6.2.1.3 (see Fig. 2).

5.2.1.1

6.2.1.1 Leather—The leather used in construction of the bag shall be harness leather (oak tanned from packer hides), hides or latigo leather (alum and vegetable tanned), or both. It shall be selected from a back or a side to contain enough area of the required thickness. Leather thickness shall be expressed in ounces (1 oz = 0.4 mm ( $\frac{1}{64}$  in.)). The above terms are explained in

Definitions Terminology D 1517.

<sup>3</sup> Annual Book of ASTM Standards, Vol 04.07.

<sup>3</sup> Available from Standardization Documents Order Desk, DODSSP, Bldg. 4, Section D, 700 Robbins Ave., Philadelphia, PA 19111-5098, <http://www.dodssp.daps.mil>.

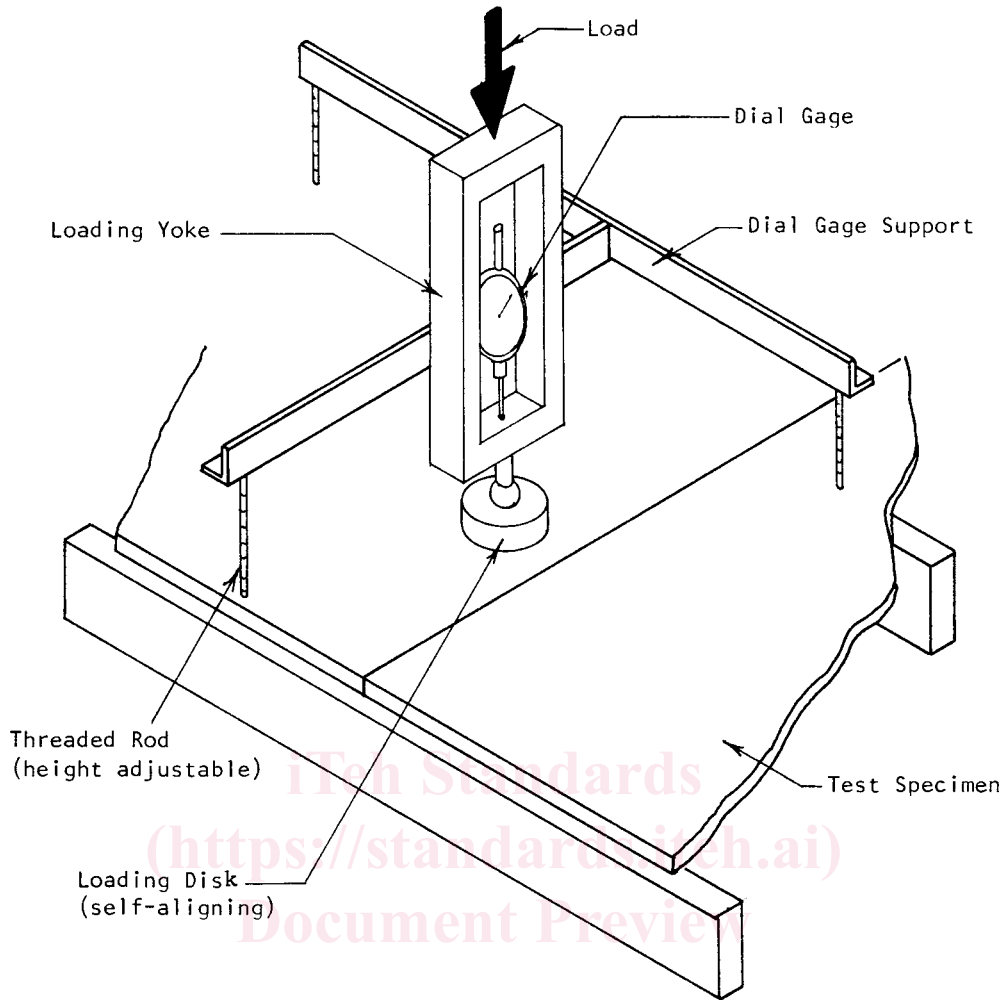

FIG. 1 Concentrated Static Load Apparatus

<https://standards.iteh.ai/catalog/standards/sist/2b1be05d-ceab-43d4-88f6-25def7939a0/astm-e661-032009>

5.2.1.2

6.2.1.2 *Thread*—Thread used to fabricate the bag shall be linen, of four or more plies, meeting the requirements for Type B, Class 1 or 2, of Fed. Spec. V-T-291E(1).

5.2.1.3

6.2.1.3 *Fabrication*— The bag shall be 710 mm (28 in.) high by 735 mm (29 in.) in circumference, with a sidewall of 8-oz leather 3 mm (1/8 in.) thick. The vertical edges shall be sewn together flesh side out and the seam shall be reinforced with a piece of 8-oz leather overlapping 9 mm (3/8 in.) on each side. The side shall then be turned hair side out and sewn to the bottom. The base (bottom disk) shall be 230 to 265 mm (9 to 10 1/2 in.) in diameter of 12-oz leather 5 mm (3/16 in.) thick. The seam attaching the sidewall to the base shall be 6 mm (1/4 in.) from the edge of the base. Two rows of stitching shall be used for the vertical sidewall seam and the seam attaching the sidewall to the base.

(a)(1) (a) The strap to hoist the bag shall be made from 8-oz leather 3 mm (1/8 in.) thick by 16 mm (5/8 in.) wide by 610 mm (24 in.) long. The strap shall be passed through holes, diametrically opposite, in the sidewalls 40 mm (1 1/2 in.) from the top of the wall. These holes shall be reinforced with pieces of 8-oz leather 76 mm (3 in.) square. The leather strap shall be passed twice through a 50-mm (2-in.) diameter lifting ring and the ends fastened by sewing, riveting, or by use of a buckle.

(b)(2) (b) To avoid excessive stretching of the leather sidewall or failure of the vertical seam, a sleeve, made from 12-oz leather, of the same type as the base of the bag, shall be fitted to slip tightly over the lower portion of the bag. This sleeve should be 250 mm (9 7/8 in.) high.

5.2.1.4

6.2.1.4 *Shot*—The bag shall be loosely filled with steel metal shot approximately 2.4 or pellets with diameters of 1 to 3.5 mm (0.094 in.) in diameter. (0.039 to 0.138 in.). Two layers of 76-mm (3-in.) thick foam rubber or similar padding shall be placed over the steel metal shot to prevent spillage during testing. Adjust the total weight of the drop bag and steel metal shot to the weight specified in Table 1, ± 1/2 %. This value shall be verified before impact tests are conducted. For spans greater than 1220 mm (48 in.), the weight of the drop bag shall be as agreed upon between the interested parties.

5.2.2

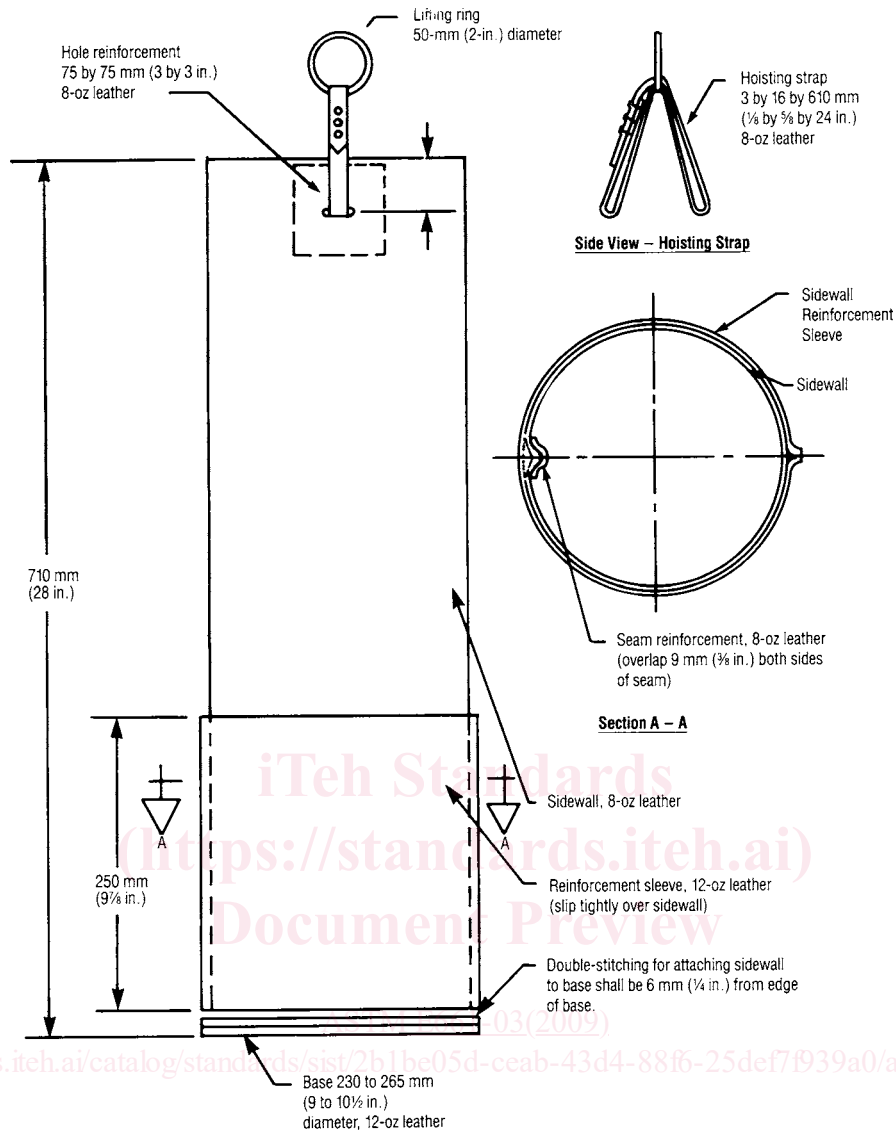

- (1) **Leather**—Use harness leather (oak-tanned from packer hides) or latigo leather (alum and vegetable tanned) (see Terminology D 1517 for definitions of terms) (1-oz-leather = 1/64 in. (0.4 mm) thick).
- (2) **Thread**—Use linen thread (minimum four-ply) in accordance with Fed. Spec. V-T-291E(1), Type B, Class 1 or 2. Double-stitch sidewall seam and seam attaching sidewall to base.
- (3) **Steel Shot**—Use steel shot (21 to 3.45-mm (0.0395 to 0.138-in.) diameter). Fill bag with steel shot and cover with two layers of 76-mm (3-in.) foam rubber. Adjust total weight of assembly to 13.6 kg (30 lb) ± 1/2 %, or more, when specified (see 56.2.1.4).

**FIG. 2 Leather Drop Bag Assembly**

**TABLE 1 Drop Bag Weights for Impact Load Tests**

Sheathing Span, <i>S</i>	Total Weight of Drop Bag (Including Shot), kg (lb)
$S \leq 610$ mm (24 in.)	13.6 (30)
$610$ mm (24 in.) < $S \leq 1220$ mm (48 in.)	27.3 (60) <sup>A</sup>
$S > 1220$ mm (48 in.)	

<sup>A</sup> See 56.2.1.4.

**6.2.2 Measuring Rod**—A measuring rod, graduated in 152-mm (6-in.) increments and equipped with a sliding pointer, shall be used to measure the drop height of the bag.

**6.**

**7. Test Specimens**

**67.1** Select specimens that are representative of the product being evaluated, both in accordance with the inherent structural properties, including density, and in accordance with the thickness and thickness tolerances characteristic of the product. Unless

otherwise specified, the number of tests shall be such as to develop the desired confidence level for each property measured, but conduct at least ten tests as a minimum for each test condition evaluated.

NOTE 2—A specimen can usually be made from a single panel, or assembled from a number of boards (see Figs. 3 and 4).

6.2

7.2 Specimen Size:

6.2.1

7.2.1 Length—The specimen length perpendicular to the main framing members shall conform to the center-to-center spacing,  $S$ , anticipated in service (Figs. 3 and 4). Where sheathing is continuous over more than one span, its length shall be equal to the minimum number of spans permitted or recommended for the product used and its intended application, multiplied by the center-to-center spacing of the framing members.

6.2.2

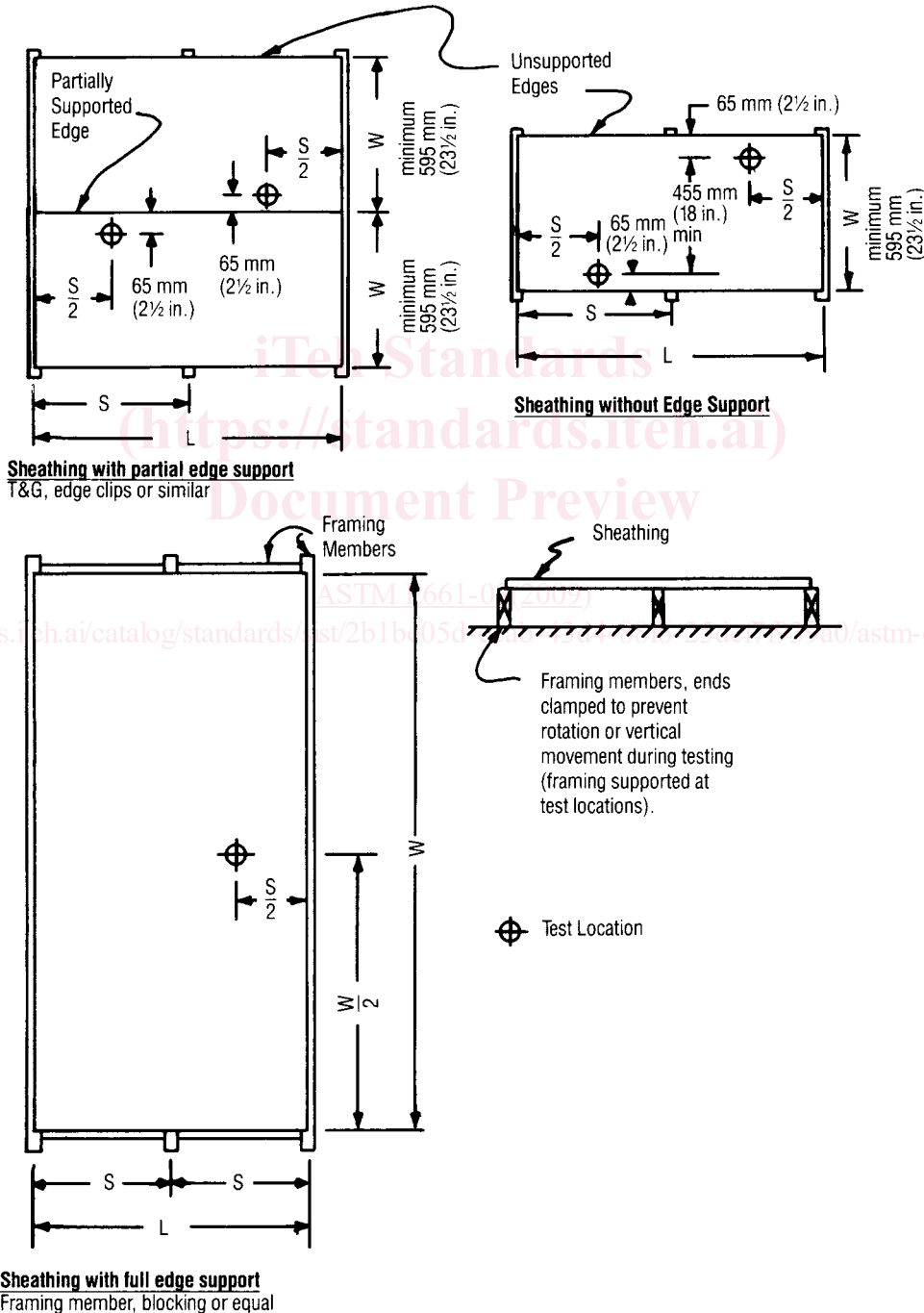

FIG. 3 Concentrated Static Load Test Specimens

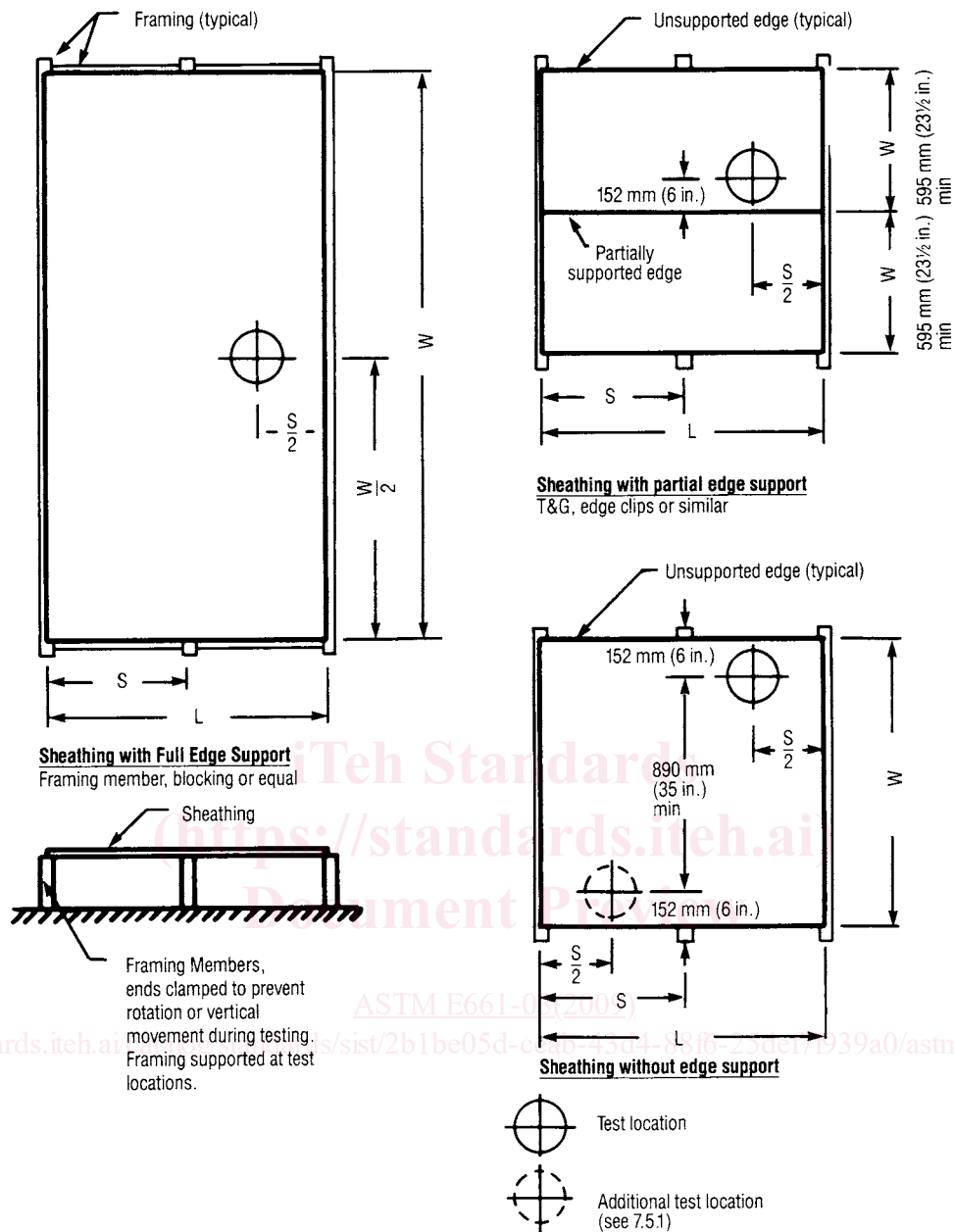

FIG. 4 Impact-Load Test Specimens

7.2.2 Width—The specimen width shall be at least 595 mm (23½ in.). The specimen width shall conform to its nominal width when edges are fully supported. When edges are unsupported or partially supported, sheathing may be trimmed to a width not less than 595 mm (23½ in.).

6.2.3

7.2.3 Thickness—Measure and report thickness of all sheathing specimens after conditioning in accordance with 6.3.17.3.1 and report.

6.2.4 Cut 7.2.4 Cut the sheathing to the required size prior to conditioning.

6.3.7.3 Conditioning of Sheathing—Prior to static and impact testing, subject sheathing to wetting and drying to simulate possible typical construction conditions. Test sheathing intended for roof applications under both dry and wet conditions, as described in 6.3.17.3.1 and 6.3.27.3.2. Test sheathing intended for subfloor or single-layer floor application both dry and in a re-dried condition after exposure to wet conditions, in accordance with 6.3.17.3.1 and 6.3.37.3.3. This sheathing may also be tested under wet conditions in accordance with 6.3.27.3.2 (see Note 1).

6.3.1

7.3.1 Dry Tests—Condition sheathing to either constant weight or moisture content or for at least 2 weeks, at  $20 \pm 3^\circ\text{C}$  ( $68 \pm 6^\circ\text{F}$ ) and  $65 \pm 5\%$  relative humidity.

6.3.2