

SLOVENSKI STANDARD
SIST EN 2878:2018+AC:2019**01-junij-2019****Nadomešča:**
SIST EN 2878:2018

Aeronavtika - Zakovne matice, samozaporne, vremensko odporne, tesnjene, premične, dvostranske, z izvrtino za valjaste vijake, iz legiranega jekla, kadmirane, mazane z MoS2 - Klasifikacija: 900 MPa (pri okoljski temperaturi)/235 °C (vključno s popravkom AC)

Aerospace series - Nuts, anchor, self-locking, air resistant, sealing, floating, two lug, with counterbore, in alloy steel, cadmium plated, MoS2 lubricated - Classification: 900 MPa (at ambient temperature)/235 °C

(standards.iteh.ai)

Luft- und Raumfahrt - Anniemuttern, selbstsichernd, druckdicht, luftbeständig, beweglich, beiderseitiger Flansch, mit zylindrischer Aussenkung, aus legiertem Stahl, verkadmet, MoS2-geschmiert - Klasse: 900 MPa (bei Raumtemperatur)/235 °C

Série aérospatiale - Écrous à river, à freinage interne, étanches à l'air, flottants, double patte, avec chambrage, en acier allié, cadmiés, lubrifiés MoS2 - Classification: 900 MPa (à température ambiante)/235 °C

Ta slovenski standard je istoveten z: EN 2878:2018+AC:2019

ICS:

21.060.20	Matice	Nuts
49.030.30	Matice	Nuts

SIST EN 2878:2018+AC:2019 en,fr,de

iTeh STANDARD PREVIEW
(standards.iteh.ai)

SIST EN 2878:2018+AC:2019

<https://standards.iteh.ai/catalog/standards/sist/6a362201-41a5-4ce6-81de-65efa8032f7/sist-en-2878-2018ac-2019>

EUROPEAN STANDARD

EN 2878:2018+AC

NORME EUROPÉENNE

EUROPÄISCHE NORM

April 2019

ICS 49.030.30

Supersedes EN 2878:2018

English Version

Aerospace series - Nuts, anchor, self-locking, air resistant, sealing, floating, two lug, with counterbore, in alloy steel, cadmium plated, MoS2 lubricated - Classification: 900 MPa (at ambient temperature)/235 °C

Série aérospatiale - Écrous à river, à freinage interne, étanches à l'air, flottants, double patte, avec chambrage, en acier allié, cadmiés, lubrifiés MoS2 - Classification: 900 MPa (à température ambiante)/235 °C

Luft- und Raumfahrt - Anniemuttern, selbstsichernd, druckdicht, luftbeständig, beweglich, beiderseitiger Flansch, mit zylindrischer Aussenkung, aus legiertem Stahl, verkadmet, MoS2-geschmiert - Klasse: 900 MPa (bei Raumtemperatur)/235 °C

This European Standard was approved by CEN on 11 June 2018 and includes the Corrigendum issued by CEN on 10 April 2019.

CEN members are bound to comply with the CEN/CENELEC Internal Regulations which stipulate the conditions for giving this European Standard the status of a national standard without any alteration. Up-to-date lists and bibliographical references concerning such national standards may be obtained on application to the CEN-CENELEC Management Centre or to any CEN member.

This European Standard exists in three official versions (English, French, German). A version in any other language made by translation under the responsibility of a CEN member into its own language and notified to the CEN-CENELEC Management Centre has the same status as the official versions.

CEN members are the national standards bodies of Austria, Belgium, Bulgaria, Croatia, Cyprus, Czech Republic, Denmark, Estonia, Finland, Former Yugoslav Republic of Macedonia, France, Germany, Greece, Hungary, Iceland, Ireland, Italy, Latvia, Lithuania, Luxembourg, Malta, Netherlands, Norway, Poland, Portugal, Romania, Serbia, Slovakia, Slovenia, Spain, Sweden, Switzerland, Turkey and United Kingdom.



EUROPEAN COMMITTEE FOR STANDARDIZATION
COMITÉ EUROPÉEN DE NORMALISATION
EUROPÄISCHES KOMITEE FÜR NORMUNG

CEN-CENELEC Management Centre: Rue de la Science 23, B-1040 Brussels

Contents		Page
European foreword		3
1	Scope	4
2	Normative references	4
3	Required characteristics	5
4	Designation	8
5	Marking	8
6	Technical specification	8

iTeh STANDARD PREVIEW
(standards.iteh.ai)

SIST EN 2878:2018+AC:2019
<https://standards.iteh.ai/catalog/standards/sist/6a362201-41a5-4ce6-81de-65efea8032f7/sist-en-2878-2018ac-2019>

European foreword

This document (EN 2878:2018+AC:2019) has been prepared by the Aerospace and Defence Industries Association of Europe - Standardization (ASD-STAN).

After enquiries and votes carried out in accordance with the rules of this Association, this Standard has received the approval of the National Associations and the Official Services of the member countries of ASD, prior to its presentation to CEN.

This European Standard shall be given the status of a national standard, either by publication of an identical text or by endorsement, at the latest by October 2019, and conflicting national standards shall be withdrawn at the latest by October 2019.

Attention is drawn to the possibility that some of the elements of this document may be the subject of patent rights. CEN shall not be held responsible for identifying any or all such patent rights.

This document includes Corrigendum 1 issued by CEN on 10 April 2019.

This document supersedes AC EN 2878:2018 AC.

The start and finish of text introduced or altered by corrigendum is indicated in the text by tags AC AC.

According to the CEN-CENELEC Internal Regulations, the national standards organizations of the following countries are bound to implement this European Standard: Austria, Belgium, Bulgaria, Croatia, Cyprus, Czech Republic, Denmark, Estonia, Finland, Former Yugoslav Republic of Macedonia, France, Germany, Greece, Hungary, Iceland, Ireland, Italy, Latvia, Lithuania, Luxembourg, Malta, Netherlands, Norway, Poland, Portugal, Romania, Serbia, Slovakia, Slovenia, Spain, Sweden, Switzerland, Turkey and the United Kingdom.

EN 2878:2018+AC:2019 (E)**1 Scope**

This European standard specifies the characteristics of self-locking, air resistant, sealing, floating, two lug anchor nuts, with counterbore, in alloy steel, cadmium plated, MoS₂ lubricated.

Classification: 900 MPa¹/235 °C².

2 Normative references

The following documents are referred to in the text in such a way that some or all of their content constitutes requirements of this document. For dated references, only the edition cited applies. For undated references, the latest edition of the referenced document (including any amendments) applies.

EN 2133, *Aerospace series — Cadmium plating of steels, with maximum specified tensile strength equal to or less than 1 450 MPa, copper, copper alloys and nickel alloys*³

EN 2424, *Aerospace series — Marking of aerospace products*

EN 2491, *Aerospace series — Molybdenum disulphide dry lubricants — Coating methods*

EN 9100, *Quality Management Systems — Requirements for Aviation, Space and Defence Organizations*

EN 9133, *Aerospace series — Quality Management Systems — Qualification Procedure for Aerospace Standard Products*

ISO 5855-2, *Aerospace — MJ threads — Part 2: Limit dimensions for bolts and nuts*

ISO 5858, *Aerospace — Nuts, self-locking, with maximum operating temperature less than or equal to 425 °C — Procurement specification*

ISO 8788, *Aerospace — Nuts, metric — Tolerances of form and position*

ISO 8940, *Aerospace — Nuts, anchor, self-locking, sealing, floating, two lug, with counterbore, with MJ threads, classifications 900 MPa (at ambient temperature)/120 °C, 900 MPa (at ambient temperature)/175 °C and 900 MPa (at ambient temperature)/235 °C — Dimensions*

AMS 3304G, *Silicone Rubber, General Purpose, 70 Durometer*⁴

TR 3791, *Aerospace series — Materials for self-locking nuts, threaded inserts and screw thread inserts of temperature classes ≤ 425 °C*⁵

¹ Corresponds to strength class of the associated bolt, the 100 per cent load of which it is able to withstand, when tested at ambient temperature, without breaking or cracking.

² Maximum temperature that the nut is able to withstand, without permanent alteration to its original characteristics, after ambient temperature has been restored. The maximum temperature is conditioned by the material.

³ Published as ASD-STAN Standard at the date of publication of this European standard (www.asd-stan.org).

⁴ Published by: Society of Automotive Engineers, Inc. (SAE), 400 Commonwealth Drive, Warrendale, PA 15096-0001, USA.

⁵ Published as ASD-STAN Technical Report at the date of publication of this standard (www.asd-stan.org).

3 Required characteristics

3.1 Configuration — Dimensions — Masses

See Figure 1 and Table 1.

Dimensions and tolerances are: in conformity with ISO 8940, expressed in millimetres and apply after cadmium plating but before MoS₂ lubrication.

Details of form not stated are at the manufacturer's option.

3.2 Tolerances of form and position

ISO 8788.

3.3 Materials

Cage, seal retainer and nut element: TR 3791.

Sealing ring: rubber, air resistant per AMS 3304 or equivalent.

3.4 Surface treatments

Cage and seal retainer: EN 2133, 5 µm min. on all surfaces which can be contacted by a 20 mm diameter ball. On all other surfaces, a continuous deposit shall be present.

Nut element:

- EN 2133, 5 µm min. on all surfaces which can be contacted by a 20 mm diameter ball. On all other surfaces, a continuous deposit shall be present.
- EN 2491, thickness not specified, mandatory on threads, optional on other surfaces.

EN 2878:2018+AC:2019 (E)

$$6,3 \sqrt{\left[\frac{3,2}{\sqrt{\quad}} \right]}^{1)}$$

Remove sharp edges 0,1 to 0,4.

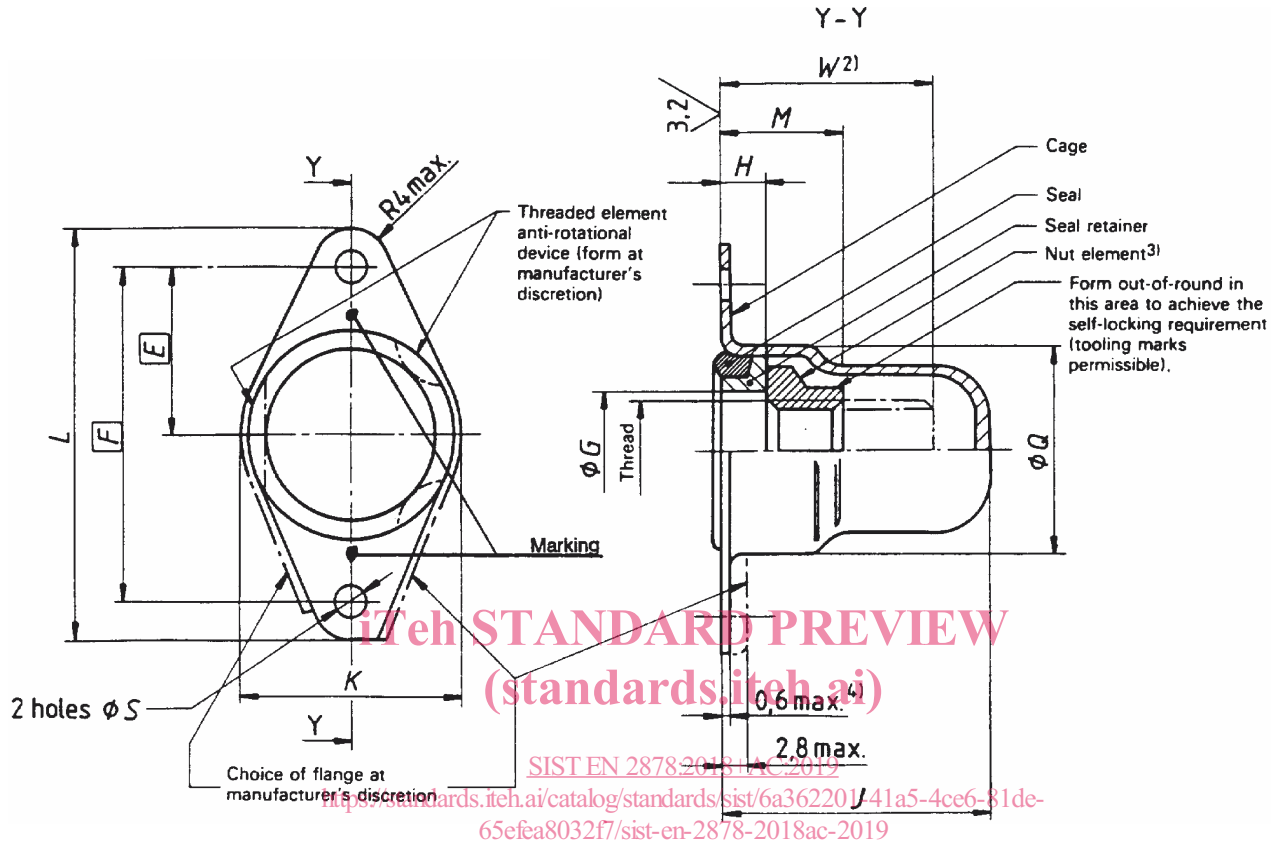
**Key**

- 1) These values in micrometres apply before surface treatment. They do not apply to threads, punched holes or sheared edges the surface texture of which will be as achieved by usual manufacturing methods.
- 2) Maximum bolt thread intrusion.
- 3) Minimum radial float of nut element: 0,5.
- 4) Lug thickness at the rivet location.

Figure 1

Table 1

Diameter code	Thread ^a	<i>E</i>	<i>F</i>	<i>G</i> min.	<i>H</i> min.	<i>J</i> max.	<i>K</i> max.	<i>L</i> max.	<i>M</i> max.	<i>Q</i> max.	<i>S</i> +0,2 0	<i>W</i> max.	Mass ^b
050	MJ5×0,8 – 4H6H	9,5	19	6	3,4	16,2	14,4	24,6	7,9	12,56	2,5	14,4	4,3
060	MJ6×1 – 4H5H	11	22	7	4,1	19,2	17	29	9,5	16		17,4	7
080	MJ8×1 – 4H5H	13	26	9		20,3	19,4	32,5	11,3	18,5	3	18,5	10

^a In accordance with ISO 5855-2. In the self-locking zone the tolerances apply before forming out-of-round.

^b Approximate values (kg/1 000 pieces), given for information purposes only.

iTeh STANDARD PREVIEW
(standards.iteh.ai)

[SIST EN 2878:2018+AC:2019](https://standards.iteh.ai/catalog/standards/sist/6a362201-41a5-4ce6-81de-65efea8032f7/sist-en-2878-2018ac-2019)
<https://standards.iteh.ai/catalog/standards/sist/6a362201-41a5-4ce6-81de-65efea8032f7/sist-en-2878-2018ac-2019>