

FINAL
DRAFT

INTERNATIONAL
STANDARD

ISO/FDIS
4254-17.2

ISO/TC 23/SC 7

Secretariat: UNI

Voting begins on:
2021-10-21

Voting terminates on:
2021-12-16

**Agricultural machinery — Safety —
Part 17:
Root crop harvesters**

Matériel agricole — Sécurité —

*Partie 17: Matériel de récolte de pommes de terre, de betteraves à
sucre et fourragères*

**iTeh STANDARD PREVIEW
(standards.iteh.ai)**

[ISO/FDIS 4254-17.2](https://standards.iteh.ai/catalog/standards/sist/9e57b284-2a98-4848-be73-553fbfb20279/iso-fdis-4254-17-2)

<https://standards.iteh.ai/catalog/standards/sist/9e57b284-2a98-4848-be73-553fbfb20279/iso-fdis-4254-17-2>

ISO/CEN PARALLEL PROCESSING

RECIPIENTS OF THIS DRAFT ARE INVITED TO SUBMIT, WITH THEIR COMMENTS, NOTIFICATION OF ANY RELEVANT PATENT RIGHTS OF WHICH THEY ARE AWARE AND TO PROVIDE SUPPORTING DOCUMENTATION.

IN ADDITION TO THEIR EVALUATION AS BEING ACCEPTABLE FOR INDUSTRIAL, TECHNOLOGICAL, COMMERCIAL AND USER PURPOSES, DRAFT INTERNATIONAL STANDARDS MAY ON OCCASION HAVE TO BE CONSIDERED IN THE LIGHT OF THEIR POTENTIAL TO BECOME STANDARDS TO WHICH REFERENCE MAY BE MADE IN NATIONAL REGULATIONS.



Reference number
ISO/FDIS 4254-17.2:2021(E)

© ISO 2021

iTeh STANDARD PREVIEW (standards.iteh.ai)

[ISO/FDIS 4254-17.2](https://standards.iteh.ai/catalog/standards/sist/9e57b284-2a98-4848-be73-553fbfb20279/iso-fdis-4254-17-2)

<https://standards.iteh.ai/catalog/standards/sist/9e57b284-2a98-4848-be73-553fbfb20279/iso-fdis-4254-17-2>



COPYRIGHT PROTECTED DOCUMENT

© ISO 2021

All rights reserved. Unless otherwise specified, or required in the context of its implementation, no part of this publication may be reproduced or utilized otherwise in any form or by any means, electronic or mechanical, including photocopying, or posting on the internet or an intranet, without prior written permission. Permission can be requested from either ISO at the address below or ISO's member body in the country of the requester.

ISO copyright office
CP 401 • Ch. de Blandonnet 8
CH-1214 Vernier, Geneva
Phone: +41 22 749 01 11
Email: copyright@iso.org
Website: www.iso.org

Published in Switzerland

Contents

	Page
Foreword.....	v
Introduction.....	vi
1 Scope.....	1
2 Normative references.....	1
3 Terms and definitions.....	2
4 Safety requirements and/or protective/risk reduction measures for all machines.....	4
4.1 General.....	4
4.2 Controls.....	4
4.3 Visibility.....	4
4.4 Haulm/leaf topping device.....	5
4.4.1 Protection against unintentional contact with the rotating tools.....	5
4.4.2 Haulm/leaf conveying device of a haulm/leaf topping device.....	7
4.4.3 Haulm/leaf loading device of a haulm/leaf topping device.....	8
4.4.4 Protection against thrown objects.....	8
4.5 Bunker.....	9
4.6 Unloading.....	9
4.7 Prevention of hazards related to blockages.....	9
4.8 Prevention of risks of unintentional contact with power-driven functional elements.....	9
4.9 Platforms used as workplace on the machine.....	10
4.9.1 General.....	10
4.9.2 Sorting platform.....	10
4.9.3 Packing platform.....	11
4.10 Other places than the operator's stations.....	12
4.11 Leaf spreading device.....	13
4.11.1 General.....	13
4.11.2 Protection against unintentional contact.....	13
4.12 Haulm spreading devices.....	17
4.12.1 Protection on the top and at the front.....	17
4.12.2 Protection at the sides.....	19
4.13 Noise reduction as safety requirement.....	19
5 Additional requirements for sieving harvesters.....	19
5.1 Digging devices.....	19
5.2 Cleaning and conveying devices.....	19
5.2.1 General.....	19
5.2.2 Cleaning belts.....	19
5.2.3 Other cleaning devices.....	19
5.2.4 Conveying devices.....	20
6 Additional requirements for root lifting harvesters.....	20
6.1 Root lifting devices.....	20
6.2 Cleaning devices.....	20
6.2.1 General.....	20
6.2.2 Cleaning turbines.....	20
6.2.3 Cleaning belts.....	22
6.2.4 Cleaning rollers.....	23
6.3 Conveying devices.....	24
7 Additional requirements for top lifting harvesters.....	24
7.1 Top lifting devices.....	24
7.2 Cleaning devices.....	26
7.3 Cleaning belts.....	26
7.4 Conveying devices.....	26
7.5 Devices in front of the top lifting devices.....	26
7.6 Haulm/leaf removing device.....	27

8	Verification of the safety requirements and/or protective/risk reduction measures	27
9	Information for use	28
9.1	Operator's manual.....	28
9.1.1	General.....	28
9.1.2	All machines.....	28
9.1.3	Sieving harvesters.....	29
9.1.4	Root lifting harvesters.....	29
9.1.5	Top lifting harvesters.....	30
9.2	Marking.....	30
9.2.1	General.....	30
9.2.2	Warnings.....	30
Annex A (informative) List of significant hazards		32
Annex B (informative) Examples of machines and components		39
Annex C (informative) Prevention of hazards related to blockages and removal of blockages on root crop harvester		51
ANNEX ZA (informative) Relationship between this European Standard and the Essential Requirements of EU Directive 2006/42/EC aimed to be covered		54
Bibliography		57

iTeh STANDARD PREVIEW
(standards.iteh.ai)

[ISO/FDIS 4254-17.2](https://standards.iteh.ai/catalog/standards/sist/9e57b284-2a98-4848-be73-553fbfb20279/iso-fdis-4254-17-2)

<https://standards.iteh.ai/catalog/standards/sist/9e57b284-2a98-4848-be73-553fbfb20279/iso-fdis-4254-17-2>

Foreword

ISO (the International Organization for Standardization) is a worldwide federation of national standards bodies (ISO member bodies). The work of preparing International Standards is normally carried out through ISO technical committees. Each member body interested in a subject for which a technical committee has been established has the right to be represented on that committee. International organizations, governmental and non-governmental, in liaison with ISO, also take part in the work. ISO collaborates closely with the International Electrotechnical Commission (IEC) on all matters of electrotechnical standardization.

The procedures used to develop this document and those intended for its further maintenance are described in the ISO/IEC Directives, Part 1. In particular, the different approval criteria needed for the different types of ISO documents should be noted. This document was drafted in accordance with the editorial rules of the ISO/IEC Directives, Part 2 (see www.iso.org/directives).

Attention is drawn to the possibility that some of the elements of this document may be the subject of patent rights. ISO shall not be held responsible for identifying any or all such patent rights. Details of any patent rights identified during the development of the document will be in the Introduction and/or on the ISO list of patent declarations received (see www.iso.org/patents).

Any trade name used in this document is information given for the convenience of users and does not constitute an endorsement.

For an explanation of the voluntary nature of standards, the meaning of ISO specific terms and expressions related to conformity assessment, as well as information about ISO's adherence to the World Trade Organization (WTO) principles in the Technical Barriers to Trade (TBT), see www.iso.org/iso/foreword.html (standards.iteh.ai)

This document was prepared by Technical Committee ISO/TC 23, *Tractors and machinery for agriculture and forestry*, Subcommittee SC 7, *Equipment for harvesting and conservation*, in collaboration with the European Committee for Standardization (CEN) Technical Committee CEN/TC 144, *Tractors and machinery for agriculture and forestry*, in accordance with the Agreement on technical cooperation between ISO and CEN (Vienna Agreement).

A list of all parts in the ISO 4254 series can be found on the ISO website.

Any feedback or questions on this document should be directed to the user's national standards body. A complete listing of these bodies can be found at www.iso.org/members.html.

Introduction

This document is a type-C standard as stated in ISO 12100:2010.

This document is of relevance, in particular, for the following stakeholder groups representing the market players with regard to machinery safety:

- machine manufacturers (small, medium and large enterprises);
- health and safety bodies (regulators, accident prevention organisations, market surveillance, etc.)

Others can be affected by the level of machinery safety achieved with the means of the document by the above-mentioned stakeholder groups:

- machine users/employers (small, medium and large enterprises);
- machine users/employees (e.g. trade unions, organizations for people with special needs);
- service providers, e.g. for maintenance (small, medium and large enterprises);
- consumers (in case of machinery intended for use by consumers).

The above-mentioned stakeholder groups have been given the possibility to participate at the drafting process of this document.

The machinery concerned and the extent to which hazards, hazardous situations or hazardous events are covered are indicated in the Scope of this document.

When requirements of this type-C standard are different from those which are stated in type-A or type-B standards, the requirements of this type-C standard take precedence over the requirements of the other standards for machines that have been designed and built according to the requirements of this type-C standard.

<https://standards.iteh.ai/catalog/standards/sist/9e57b284-2a98-4848-be73-553fbfb20279/iso-fdis-4254-17-2>

NOTE Examples of machine and components, illustrating the terms and definitions in [Clause 3](#), are given in [Annex B](#).

Agricultural machinery — Safety —

Part 17: Root crop harvesters

1 Scope

This document, intended to be used together with ISO 4254-1, specifies the safety requirements and their verification for the design and construction of the following types of root crop harvesting machines trailed, mounted or self-propelled:

- sieving harvesters,
- root lifting harvesters,
- top lifting harvesters,

which carry out more than one of the following operations: haulm/leaf topping, digging/taking-in/lifting, cleaning, conveying and unloading of root crops.

This document is also applicable for haulm/leaf toppers used individually.

This document is not applicable to cleaner-loaders which operate from a heap of beet. For these type of machines, additional hazards are, at present, not dealt with in this document.

In addition, it specifies the type of information on safe working practices to be provided by the manufacturer.

The list of significant hazards covered in this document is given in [Annex A](#). It also indicates the hazards which have not been dealt with.

Environmental aspects have not been considered in this document. Noise has been considered partly in this document.

This document applies primarily to machines which are manufactured after the date of its publication.

2 Normative references

The following documents are referred to in the text in such a way that some or all of their content constitutes requirements of this document. For dated references, only the edition cited applies. For undated references, the latest edition of the referenced document (including any amendments) applies.

ISO 4254-1:2013, *Agricultural machinery — Safety — Part 1: General requirements*

ISO 9533:2010, *Earth-moving machinery — Machine-mounted audible travel alarms and forward horns — Test methods and performance criteria*

ISO 11684:1995, *Tractors, machinery for agriculture and forestry, powered lawn and garden equipment — Safety signs and hazard pictorials — General principles*

ISO 12100:2010, *Safety of machinery — General principles for design — Risk assessment and risk reduction*

ISO 13850:2015, *Safety of machinery — Emergency stop function — Principles for design*

ISO 13857:2019, *Safety of machinery — Safety distances to prevent hazard zones being reached by upper and lower limbs*

ISO 15534-3:2000, *Ergonomic design for the safety of machinery — Part 3: Anthropometric data*

3 Terms and definitions

For the purposes of this document, the terms and definitions given in ISO 4254-1:2013, ISO 12100:2010 and the following apply.

ISO and IEC maintain terminological databases for use in standardization at the following addresses:

- ISO Online browsing platform: available at <https://www.iso.org/obp>
- IEC Electropedia: available at <https://www.electropedia.org/>

3.1 sieving harvester

harvesting machine which digs the crops together with a bed of soil and which separates the crops from the soil by sieving

Note 1 to entry: These machines are typically used for harvesting of potatoes.

3.2 root lifting harvester

harvesting machine which lifts individual crops of a row and which separates remaining adhering soil from the crops

Note 1 to entry: These machines are typically used for harvesting of beets.

3.3 top lifting harvester

harvesting machine which lifts crops of a row mainly by the leaf or haulm by using a clamping belt and which separates remaining adhering soil from the crops

Note 1 to entry: These machines are typically used for harvesting of carrots or leeks.

3.4 haulm/leaf conveying device

device for transport of haulms/leaves to haulm/leaf spreader or to the loading device, if any, or to the outside of the machine

3.5 cleaning device

device mainly intended to separate the crop from the soil adhering to it

3.6 crop conveying device

device which transports the crop from one part of the machine to another

3.7 unloading device

device which transfers the crop out of the machine

3.8 bunker

device to collect the crop on the machine which can be equipped with a system to raise and combined with an *unloading device* (3.7)

3.9 haulm/leaf topping device

device to remove and to evacuate the haulm/leaf prior to lifting the crop

Note 1 to entry: This device can be used also individually as haulm/leaf topper.

3.9.1**rotor**

rotating device intended to remove the haulm/leaf of crops and/or to clean the top part of the crop still in the ground

3.9.2**leaf spreading device**

device which distributes leaves evenly on the soil surface

3.9.3**haulm spreading device**

device which distributes haulms evenly on the soil surface

3.10**haulm de-vining device**

device to separate haulm from the potatoes after lifting

3.11**digging device**

device of a *sieving harvester* (3.1) to dig the crop together with soil from the field

3.12**clod and stone removal devices**

devices to remove unwanted soil, stones and clods from the lifted crop

3.13**sorting platform**

workplace for sorting on the machine

3.14**packing platform**

workplace on the machine for manual packing of crops in bags or boxes with an area for transfer of the bags or boxes to a transport vehicle

3.15**inspection platform**

workplace on the machine for observing of the crop flow and the quality of the crop harvested

3.16**haulm/leaf loading device**

device which transports haulms/leaves collected at the discharge outlet

3.17**root lifting device**

device of a *root lifting harvester* (3.2) which extracts roots crops from the soil

3.18**haulm/leaf cutting device**

device to remove the haulm/leaf by cutting after lifting the crop located just at the beginning of the clamping belt

3.19**haulm/leaf removing device**

device to remove the residual haulm/leaf after lifting the crop located in upper area of the clamping belt

3.20**top lifting device**

clamping belt in combination with a share as support for lifting the crop from the soil by lifting the crop by the haulm/leaf

3.21

torpedo

tapered or cone-shaped device for raising haulm/leaf before lifting

Note 1 to entry: See [Figures 15](#) and [B.15](#).

4 Safety requirements and/or protective/risk reduction measures for all machines

4.1 General

4.1.1 Machinery shall conform with the safety requirements and/or protective/risk reduction measures of this clause. In addition, the machine shall be designed in accordance with the principles of ISO 12100:2010, Clause 4, for hazards relevant, but not significant, which are not dealt with by this document.

4.1.2 Except where otherwise specified in this document, the machine shall be in accordance with the requirements of ISO 4254-1:2013 and with ISO 13857:2019, Tables 1, 3, 4 and 6 as appropriate.

4.2 Controls

4.2.1 The starting and the stopping of the moving parts shall be controllable only from the driver's station of the self-propelled machine and in case of trailed and mounted machines only from the driver's station of the towing machine. If this is not possible for particular functions or not useful (e.g. for removing of blockages), the controls for these particular functions may be located on the machine provided they can be operated from a safe position.

4.2.2 The lowering of the bunker shall be controllable from the driver's station and the control shall be of hold-to-run-type.

4.2.3 On machines with a sorting platform, emergency stop equipment in accordance with ISO 13850:2015 shall be accessible from each workplace on the platform to stop hazardous movements, but at least the conveyor of the sorting platform. The accessibility of the emergency stop equipment shall be determined according to ISO 15534-3:2000. In case of an emergency stop activation, a clear signal shall be transmitted to the driver in order alert the driver to stop further movements by switching off the power transmission.

4.2.4 The controls for the adjustment of moving parts shall be located so that they can be operated from the driver's station and/or the sorting platform and with the guards in guarding position. The operator's manual shall include an appropriate notice on the need to adjust the driving speed and/or the speed of the functional components of the machine to the conditions of work.

4.3 Visibility

4.3.1 Self-propelled machines shall be fitted with an audible warning alarm in accordance with ISO 9533:2010. This alarm shall be automatically engaged during reversing manoeuvres.

4.3.2 This alarm is not required if the machine is equipped with a closed-circuit television (CCTV) which permits the driver to have a clear view on the rear of the machine.

4.3.3 In direction of travel lateral visibility to view the outermost edges of the machine shall be provided. If this is not possible by direct view, mirrors or any other equivalent means shall be provided.

4.4 Haulm/leaf topping device

4.4.1 Protection against unintentional contact with the rotating tools

4.4.1.1 General

Machines shall be designed or guarded in such a way that any unintentional contact with the rotating tools at the front, at the rear, at the sides and on the top is avoided.

4.4.1.2 Protection on the top, at the front and the rear

4.4.1.2.1 On the top, the protection shall be achieved by an imperforate guard. The front and rear edge of this imperforate guard shall be located at a maximum height of 400 mm from the lowest point of the tools path and at a minimum horizontal distance of 200 mm from the tools path [see [Figure 1 a](#)].

4.4.1.2.2 The protection at the front and the rear shall be achieved by the extension of the upper imperforate guard to the front and to the rear [see [Figure 1 a](#)].

4.4.1.2.3 For rotors with a vertical drive shaft, the protection on the front and back can alternatively be achieved by covering the bottom edge of the top cover by at least 3 mm downwards (see [Figure 2](#)) and stopping the tools when the rotor is in the highest position.

4.4.1.3 Protection at the sides

4.4.1.3.1 In the accessible zone, the lateral protection shall be:

- an imperforate guard, located near the tools and in such a way that its lower edge extends by a minimum of 3 mm below the tools path [see [Figure 1 b](#)]; or
- in case the lower edge of the imperforate guard does not extend by a minimum of 3 mm below the tools path, the lower edge of this imperforate guard shall be located at a maximum height of 400 mm from the lowest point of the tools path and additionally by a barrier located at a maximum height of 400 mm from the lowest point of the tools path and at a minimum horizontal distance of 200 mm from the tools path [see [Figure 1 c](#)]. If the height of the barrier is more than 400 mm from the lowest point of the tools path the barrier shall be located along a contour with angle of 45° to the exterior whereby the maximum height of the barrier shall not exceed 800 mm. Barriers at the sides can be foldable for transport. They shall remain attached to the machine and shall be kept fixed in their position. The operation of the tools shall be avoided when the barrier is not in protective position (e.g. by restriction of the function of the machine components in this situation); or
- a combination of these two previous protective devices.

4.4.1.3.2 The projection on a horizontal plane of these protective devices shall be continuous.

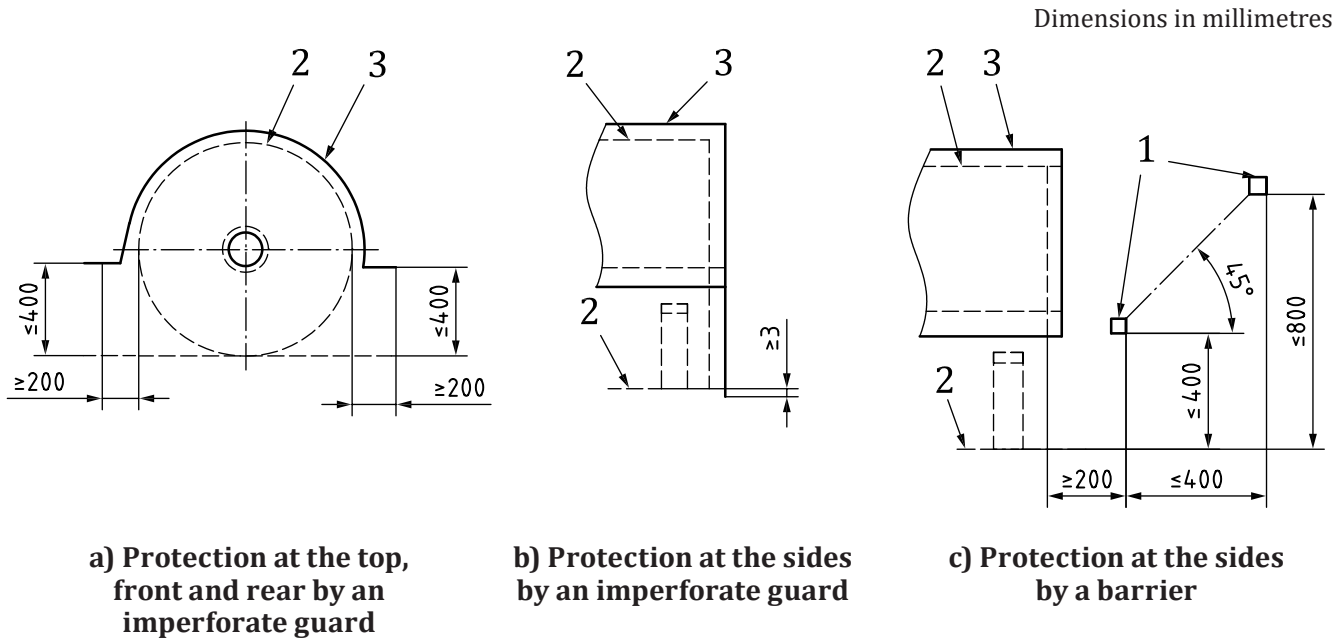

Key

- 1 barrier
- 2 tools path
- 3 imperforate guard

iTeh STANDARD PREVIEW
(standards.iteh.ai)

Figure 1 — Haulm/leaf topping device with horizontal axis — Protective devices

ISO/FDIS 4254-17.2

<https://standards.iteh.ai/catalog/standards/sist/9e57b284-2a98-4848-bc75-553fbfb20279/iso-fdis-4254-17-2>

Dimensions in millimetres

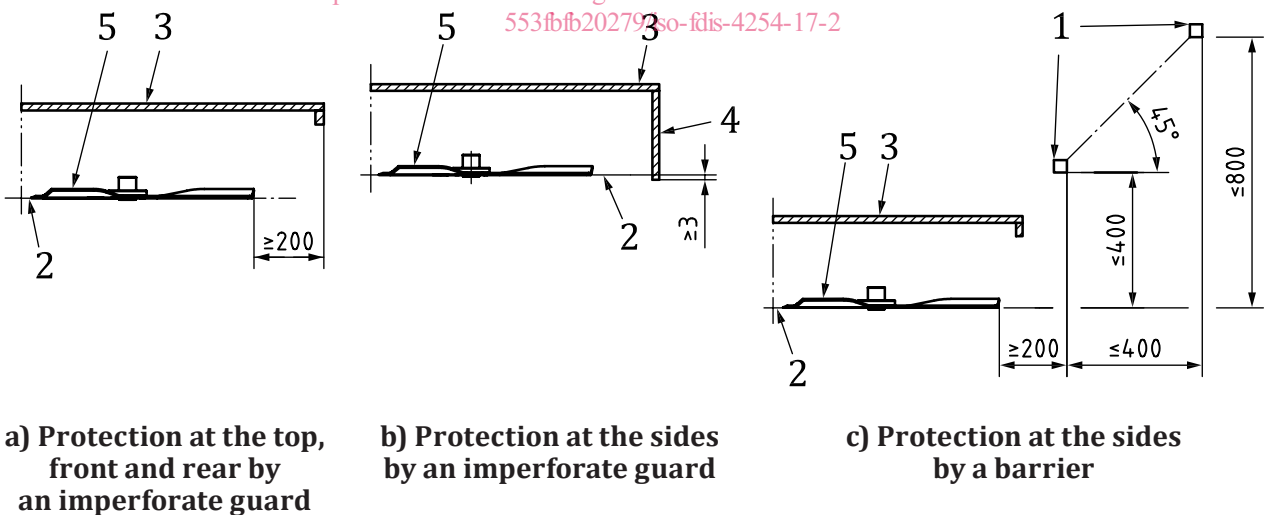

Key

- 1 barrier
- 2 tools path
- 3 imperforate guard on the top
- 4 imperforate at the side
- 5 tools

Figure 2 — Haulm/leaf topping device with vertical axis — Protective devices

4.4.2 Haulm/leaf conveying device of a haulm/leaf topping device

4.4.2.1 General

Any mobile elements of the haulm/leaf conveying device located less than 850 mm from the outer contour of the machine shall be guarded except the discharge outlet. There shall be no crushing and shearing points at the discharge outlet.

4.4.2.2 Protection of the discharge outlet at the top

On the top, the protection shall be achieved by an imperforate guard which extends beyond the outer part of the haulm/leaf conveying device by a minimum of 150 mm (see [Figure 3](#)). When a conveyor belt is used, the lower edge of the top guard shall be placed at 200 mm maximum above the upper plane of the conveyor belt (see [Figure 4](#)).

4.4.2.3 Protection of the discharge outlet at the sides

The lateral part of conveying belts itself shall be guarded against unintentional contact. The lateral part of augers shall be guarded with imperforate guards.

4.4.2.4 Protection of the discharge outlet at the front

The protection at the front shall be achieved by:

- when an auger is used, a fixed guard, the lower end of which shall extend at least 50 mm below the axis of the screw (see [Figure 3](#));
- when a conveyor belt is used, the protection at the front is given by the guard on the top (see [Figure 4](#)); or
- a mobile guard which completely seals the discharge outlet and automatically returns to the closed position when no more material is ejected (see [Figure 5](#)).

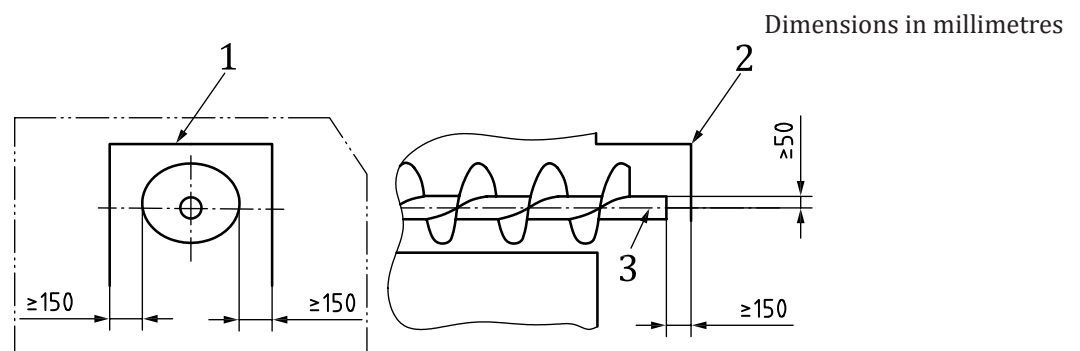

Key

- 1 imperforate top guard
- 2 fixed guard
- 3 axis of the screw

Figure 3 — Protection of the discharge outlet in case of an auger

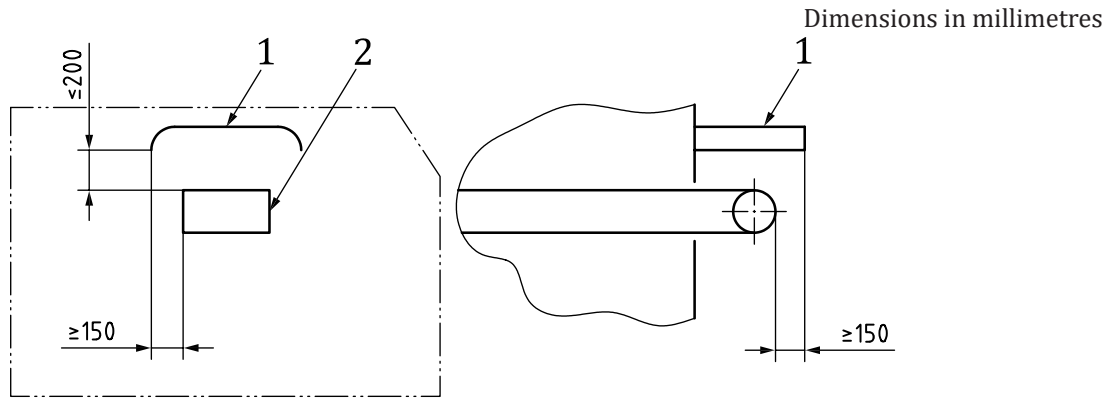

Key

- 1 imperforate top guard
- 2 conveyor belt

Figure 4 — Protection of the discharge outlet in case of a conveyor belt

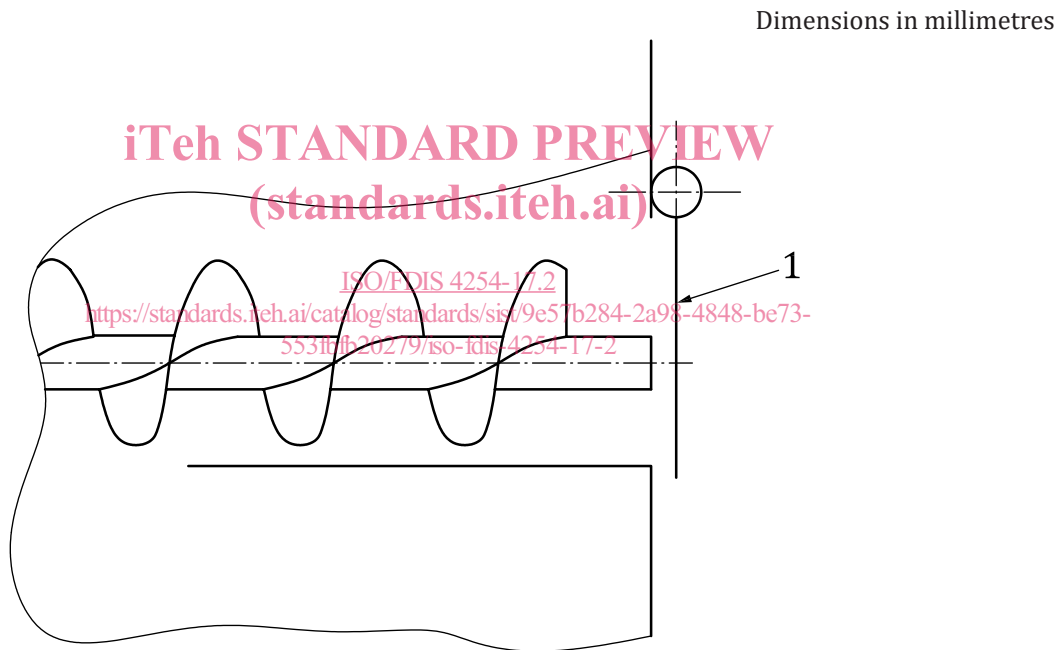

Key

- 1 mobile guard

Figure 5 — Protection of the discharge outlet by a mobile guard

4.4.3 Haulm/leaf loading device of a haulm/leaf topping device

The haulm/leaf loading device shall meet [4.1](#).

4.4.4 Protection against thrown objects

Sufficient protection against thrown parts shall be ensured. A warning of residual hazards according to [9.2.2](#) shall be provided.

4.5 Bunker

4.5.1 Within accessible zones, between moving parts of the bunker and the bunker and other parts of the machine, there shall be no shearing or pinching points. This does not apply for supporting points for stabilization of the bunker located within the machine at a minimum distance of 550 mm from the outer contour of the machine and which are not accessible from workplaces on the machine.

4.5.2 Supports in accordance with ISO 4254-1:2013, 4.11 shall be provided in order to enable maintenance and service operations to be carried out by the operator under the bunker in raised position.

4.5.3 The distribution auger shall be guarded to prevent any contact from the driver's station, from the ground or from any platform.

4.6 Unloading

4.6.1 The machine shall be so designed that the operator can supervise the unloading process from the driver's station.

4.6.2 Supports in accordance with ISO 4254-1:2013, 4.11 shall be provided in order to enable maintenance and service operations to be carried out by the operator under unloading devices in raised position. It shall be possible for the operator to fit and to remove the mechanical supports from outside the hazard zone.

4.6.3 The unloading devices shall be supplied with a device to lock them in the transport position according to ISO 4254-1:2013, 4.9.

4.6.4 Machines shall be stable during unloading. This requirement is checked in the following conditions:

- the machine is placed on a slope of 5°, with its longitudinal axis positioned across the slope;
- in the case of lateral unloading, the unloading shall be directed down slope;
- in the case of rear unloading, the machine shall be placed successively up the slope and across the slope;
- when the unloading device is lifted and/or tilted at its maximum position, a vertical force equal to the load capacity of the unloading device is applied downwards at the centre of the unloading device.

4.7 Prevention of hazards related to blockages

Following the general principles for risk reduction, the most effective way to avoid risks related to blockages is to remove the risk by taking measures to ensure that no interruption in crop flow takes place. If this is not possible in all working conditions, including reasonably foreseeable misuse, examples for the prevention of hazards related to blockages and the removal of blockages are given in [Annex C](#).

4.8 Prevention of risks of unintentional contact with power-driven functional elements

Self-propelled machines which have an electrically activated power-driven functional elements engagement mechanism shall have a system that prevents engagement of the power-driven functional elements mechanism if the operator is not in the operator's work station and that automatically disengages the power-driven functional elements mechanism when the operator leaves the operator's work station. The maximum delay time for triggering the disengagement shall be 7 s. Power-driven