



Designation: F1164 – 97(Reapproved 2009)^{ε1}

Standard Test Method for Evaluation of Transparent Plastics Exposed to Accelerated Weathering Combined with Biaxial Stress¹

This standard is issued under the fixed designation F1164; the number immediately following the designation indicates the year of original adoption or, in the case of revision, the year of last revision. A number in parentheses indicates the year of last reapproval. A superscript epsilon (ϵ) indicates an editorial change since the last revision or reapproval.

^{ε1} NOTE—Editorial changes were made throughout in June 2009.

1. Scope

1.1 This test method covers the resistance of transparent plastics exposed to environmental conditioning (accelerated weathering) under a biaxial stress state induced by a pressure cell/test fixture.

1.2 The values stated in acceptable metric units are to be regarded as the standard.

1.3 *This standard does not purport to address all of the safety concerns, if any, associated with its use. It is the responsibility of the user of this standard to establish appropriate safety and health practices and determine the applicability of regulatory limitations prior to use.*

2. Referenced Documents

2.1 *ASTM Standards:*²

D1003 Test Method for Haze and Luminous Transmittance of Transparent Plastics

D3359 Test Methods for Measuring Adhesion by Tape Test

G26 Practice for Operating Light-Exposure Apparatus (Xenon-Arc Type) With and Without Water for Exposure of Nonmetallic Materials (Discontinued 2001) (Withdrawn 2000)³

G53 Practice for Operating Light-and Water-Exposure Apparatus (Fluorescent UV-Condensation Type) for Exposure of Nonmetallic Materials (Withdrawn 2000)³

G90 Practice for Performing Accelerated Outdoor Weathering of Nonmetallic Materials Using Concentrated Natural Sunlight

¹ This test method is under the jurisdiction of ASTM Committee F07 on Aerospace and Aircraft and is the direct responsibility of Subcommittee F07.08 on Transparent Enclosures and Materials.

Current edition approved May 15, 2009. Published June 2009. Originally approved in 1988. Last previous edition approved in 2003 as F1164 – 07(2003). DOI: 10.1520/F1164-97R09E01.

² For referenced ASTM standards, visit the ASTM website, www.astm.org, or contact ASTM Customer Service at service@astm.org. For Annual Book of ASTM Standards volume information, refer to the standard's Document Summary page on the ASTM website.

³ The last approved version of this historical standard is referenced on www.astm.org.

3. Summary of Test Method

3.1 This test method consists of measuring and recording the haze and light transmittance of an unexposed circular plate test specimen; mounting the specimen in the test fixture; pressurizing the fixture to induce the desired biaxial stress in the specimen; and exposing the stressed specimen to specific accelerated weathering conditions. After conditioning, the specimen is removed and haze/transmittance are measured to determine any changes in value. Coating adhesion is measured when applicable.

3.2 The resistance of the plastic to stress-during-weathering is determined by the onset of crazing, the change in haze and luminous transmittance, and adhesion of coating.

4. Significance and Use

4.1 The degradation of optical properties of transparent plastics is the single greatest cause for in-service removal and replacement. Some optical qualities are inherent in the geometry, manufacturing process, and materials, and remain relatively unchanged after manufacture, while others are subject to gradual change during exposure to the service environment. Factors having an influence on the crazing of transparent plastics include stress, ultraviolet (UV), moisture, and temperature. Sufficient data has been generated to make it evident that real-world conditioning must be experienced by developmental test specimens, as opposed to testing new unexposed material to determine durability, prior to in-service usage. However, the laboratory simulation of natural weathering, and especially accelerated simulation, is imprecise and correlation of results obtained for different plastics or from using different exposure apparatus should not be attempted until a valid database has been generated for such cross-correlation.

5. Apparatus

5.1 *Manifold Test Fixture*—An exploded view of the pressure-cell/test-fixture used to induce a biaxial stress state in a clamped specimen is illustrated in Fig. 1. The mounting plate and clamping ring for a 76.2-mm (30-in.) wide three-cell test fixture are detailed in Fig. 2. A 254-mm (10-in.) wide single-cell fixture or a 508-mm (20-in.) wide double-cell fixture is also acceptable.

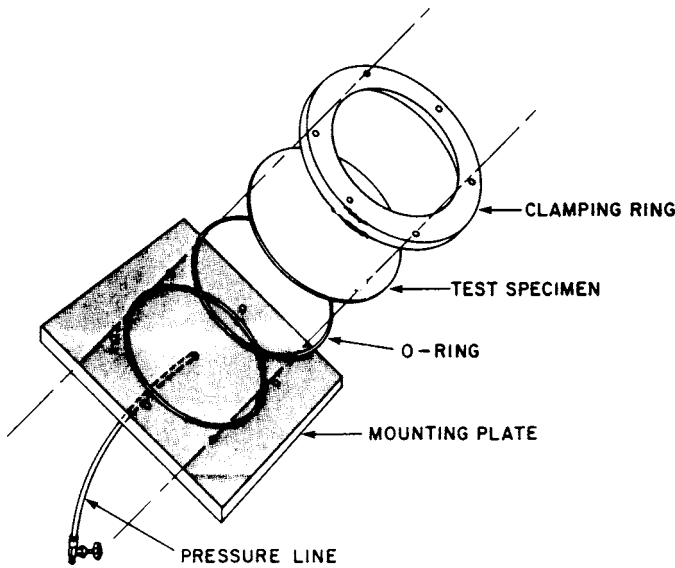

FIG. 1 Stress Weathering Test Apparatus

5.2 Accelerated Weathering Apparatus:

5.2.1 Operating procedures for using water- or light-exposure apparatus, or both, employing a Xenon-arc light source to simulate the deterioration caused by accelerated weathering exposure, shall comply with Practice G26.

5.2.2 Operating procedures for using fluorescent UV and condensation apparatus to simulate the deterioration caused by accelerated weathering exposure shall comply with Practice G53.

5.2.3 Operating procedures for using Fresnel-reflecting concentrators employing the sun as a source, with or without water spray cycles, to simulate the deterioration caused by accelerated weathering exposure, shall comply with Practice G90.

5.3 Hazemeter—The Hazemeter shall conform to the requirements of Test Method D1003.

6. Test Specimens

6.1 Use at least three specimens for each material being tested and for each specified exposure. The specimens shall be as follows: clean, transparent circular plates, 0.216 m (8.500 in.) in diameter, having both sides substantially plane and parallel; specimen nominal thickness being 0.00508 m (0.200 in.).

7. Conditioning

7.1 Conduct tests in the standard laboratory atmosphere.

8. Procedure

8.1 Code mark each specimen. Measure and record haze and transmittance at the plate center prior to exposure.

8.2 Circumferentially clamp specimens in the manifold test fixture using 2.825 J (25 in.-lb) bolt torque, and pressurize to induce an outer surface (tensile) strain of $13.8 \times 10^6 (1-\nu)/E$ metre/metre (2000 (1- ν)/E inch/inch) in the center of the specimen (note that this strain corresponds to a tensile stress of 13.8×10^6 Pa or 2000 psi), where ν = Poisson's ratio at room temperature and E = modulus of elasticity (Pa or psi) at room

temperature for the test material. For coated material, the outer tensile test/exposure side of each specimen shall be the coated surface.

8.2.1 Using 5.334 mm (0.210 in.) thick stretched acrylic, $\nu = 0.35$, and $E = 3.10 \times 10^9$ Pa (450 000 psi), a calibrated pressure of 80.0×10^3 Pa (11.6 psi) induced an outer surface strain of 2.888×10^{-3} m/m (2888 μ n./in.); being the equivalent of a 13.8×10^6 Pa (2000 psi) stress level in the center of the test specimen.

8.2.2 Knowing ν , the pressure required to induce a biaxial stress of 13.8×10^6 Pa (2000 psi) in the center of a transparent specimen of nominal 0.00508 m (0.200 in.) thickness may be theoretically calculated as follows:

$$SI \text{ Units: } M = \frac{(13.8 \times 10^6) t^2}{6} \tag{1}$$

$$\text{Inch - Pound Units: } M = \frac{2000 t^2}{6} \tag{2}$$

where:

M = bending moment at plate center (lb-in./in. or N-m/m) and

t = plate thickness, in. or m.

The desired pressure is as follows:

$$P = \frac{16 M}{a^2 (1 + \nu)} \tag{3}$$

where: a = distance from plate center to clamped edge = 0.0984 m (3.875 in.) or

$$SI \text{ Units: } P = \frac{1652 M}{1 + \nu} \tag{4}$$

$$\text{Inch - Pound Units: } P = \frac{1.065 M}{1 + \nu} \tag{5}$$

8.3 In accordance with the procedures in 5.2, condition the specimens under stress for 1, 2, 3, 4, and 5 equivalent years of accelerated weathering. Using a fluorescent ultraviolet condensation test chamber with UV B-313 lamps, an operating temperature of 48.89°C (120°F), alternate cycles of 7 h UV followed by 5 h of condensation, each equivalent year of natural weathering may be simulated by 168 h of run time. Using the Fresnel-reflector accelerated outdoor exposure test machines, parameters to establish an equivalent year of real-time weathering shall comply with the guidelines presented in Practice G90.

8.4 After each equivalent year of conditioning under stress, measure haze and transmittance at the plate center in accordance with Test Method D1003. The onset of crazing and severity of crazing, including a description of the appearance and location of crazing as detected by careful visual examination aided by reflected light, should be noted.

8.5 After each equivalent year of conditioning under stress, measure coating adhesion of coated material specimens using Test Method B—Cross-Cut Tape Test of D3359-93, Test Methods for Measuring Adhesion by Tape Test. Scribe no less than a 12-line grid pattern (approximately 25 complete squares) in the manner prescribed by D3359. Apply a strip of