



SLOVENSKI STANDARD
oSIST prEN 4165-006:2021

01-oktober-2021

Aeronavtika - Konektorji, električni, pravokotni, modularni - Stalna delovna temperatura 175 °C - 006. del: Vtič z 2 ali 4 moduli, serija 2 - Standard za proizvod

Aerospace series - Connectors, electrical, rectangular, modular - Operating temperature 175 °C continuous - Part 006: Plug for 2 and 4 modules, series 2 - Product standard

Luft- und Raumfahrt - Elektrischer Rechtecksteckverbinder in modularer Bauweise - Betriebstemperatur 175 °C konstant - Teil 006: Freier Steckverbinder mit 2 und 4 Modulen, Serie 2 - Produktnorm

(standards.iteh.ai)

[oSIST prEN 4165-006:2021](https://standards.iteh.ai/catalog/standards/sist/4c3e9536-3d7d-428e-8b2e-38926c944cb7/osist-pr-en-4165-006-2021)

[https://standards.iteh.ai/catalog/standards/sist/4c3e9536-3d7d-428e-8b2e-](https://standards.iteh.ai/catalog/standards/sist/4c3e9536-3d7d-428e-8b2e-38926c944cb7/osist-pr-en-4165-006-2021)

Ta slovenski standard je istoveten z: prEN 4165-006

ICS:

31.220.10	Vtiči in vtičnice, konektorji	Plug-and-socket devices. Connectors
49.060	Letalska in vesoljska električna oprema in sistemi	Aerospace electric equipment and systems

oSIST prEN 4165-006:2021

en,fr,de

iTeh STANDARD PREVIEW
(standards.iteh.ai)

[oSIST prEN 4165-006:2021](#)

<https://standards.iteh.ai/catalog/standards/sist/4c3e9536-3d7d-428e-8b2e-38926c944cb7/osist-pren-4165-006-2021>

EUROPEAN STANDARD
NORME EUROPÉENNE
EUROPÄISCHE NORM

DRAFT
prEN 4165-006

August 2021

ICS 49.060

Will supersede EN 4165-006:2007

English Version

**Aerospace series - Connectors, electrical, rectangular,
modular - Operating temperature 175 °C continuous - Part
006: Plug for 2 and 4 modules, series 2 - Product standard**

Luft- und Raumfahrt - Elektrischer
Rechtecksteckverbinder in modularer Bauweise -
Betriebstemperatur 175 °C konstant - Teil 006: Freier
Steckverbinder mit 2 und 4 Modulen, Serie 2 -
Produktnorm

This draft European Standard is submitted to CEN members for enquiry. It has been drawn up by the Technical Committee ASD-STAN.

If this draft becomes a European Standard, CEN members are bound to comply with the CEN/CENELEC Internal Regulations which stipulate the conditions for giving this European Standard the status of a national standard without any alteration.

This draft European Standard was established by CEN in three official versions (English, French, German). A version in any other language made by translation under the responsibility of a CEN member into its own language and notified to the CEN-CENELEC Management Centre has the same status as the official versions.

CEN members are the national standards bodies of Austria, Belgium, Bulgaria, Croatia, Cyprus, Czech Republic, Denmark, Estonia, Finland, France, Germany, Greece, Hungary, Iceland, Ireland, Italy, Latvia, Lithuania, Luxembourg, Malta, Netherlands, Norway, Poland, Portugal, Republic of North Macedonia, Romania, Serbia, Slovakia, Slovenia, Spain, Sweden, Switzerland, Turkey and United Kingdom.

Recipients of this draft are invited to submit, with their comments, notification of any relevant patent rights of which they are aware and to provide supporting documentation.

Warning : This document is not a European Standard. It is distributed for review and comments. It is subject to change without notice and shall not be referred to as a European Standard.



EUROPEAN COMMITTEE FOR STANDARDIZATION
COMITÉ EUROPÉEN DE NORMALISATION
EUROPÄISCHES KOMITEE FÜR NORMUNG

CEN-CENELEC Management Centre: Rue de la Science 23, B-1040 Brussels

Contents		Page
European foreword		3
1	Scope.....	4
2	Normative references.....	4
3	Terms and definitions.....	4
4	Required characteristics	4
5	Clicker-nut plug.....	5
5.1	For 2 modules classes W, F, J, M and A.....	5
5.2	For 4 modules classes W, F, J, M and A.....	6
5.3	Plug class.....	6
6	Designation	8
7	Marking	8
8	Technical specification	8
Bibliography		9

<https://standards.iteh.ai/catalog/standards/sist/4c3e9536-3d7d-428e-8b2e-38926c944cb7/osist-pren-4165-006-2021>
 oSIST prEN 4165-006:2021

European foreword

This document (prEN 4165-006:2021) has been prepared by the Aerospace and Defence Industries Association of Europe — Standardization (ASD-STAN).

After enquiries and votes carried out in accordance with the rules of this Association, this document has received the approval of the National Associations and the Official Services of the member countries of ASD-STAN, prior to its presentation to CEN.

This document is currently submitted to the CEN Enquiry.

This document will supersede EN 4165-006:2007.

iTeh STANDARD PREVIEW (standards.iteh.ai)

[oSIST prEN 4165-006:2021](https://standards.iteh.ai/catalog/standards/sist/4c3e9536-3d7d-428e-8b2e-38926c944cb7/osist-pren-4165-006-2021)

<https://standards.iteh.ai/catalog/standards/sist/4c3e9536-3d7d-428e-8b2e-38926c944cb7/osist-pren-4165-006-2021>

prEN 4165-006:2021 (E)**1 Scope**

This document defines the plug series 2, for 2 and 4 modules used in the family of rectangular electrical connectors. The receptacles corresponding to those plugs are defined in EN 4165-002.

2 Normative references

The following documents are referred to in the text in such a way that some or all of their content constitutes requirements of this document. For dated references, only the edition cited applies. For undated references, the latest edition of the referenced document (including any amendments) applies.

EN 4165-001, *Aerospace series - Connectors, electrical, rectangular, modular - Operating temperature 175 °C continuous - Part 001: Technical specification*

EN 4165-002, *Aerospace series - Connectors, electrical, rectangular, modular - Operating temperature 175 °C continuous - Part 002: Specification of performance and contact arrangements*

3 Terms and definitions

For the purposes of this document, the terms and definitions given in EN 4165-001 apply.

ISO and IEC maintain terminological databases for use in standardization at the following addresses:

- ISO Online browsing platform: available at <https://www.iso.org/obp>

- IEC Electropedia: available at <https://www.electropedia.org/>

ITeH STANDARD PREVIEW
(standards.iteh.ai)

4 Required characteristics

See Figure 1 and Table 1 for 2 modules. [oSIST prEN 4165-006:2021](https://standards.iteh.ai/catalog/standards/sist/4c3e9536-3d7d-428e-8b2e-38926c944cb7/osist-pren-4165-006-2021)

See Figure 2 and Table 2 for 4 modules.

5 Clicker-nut plug

5.1 For 2 modules classes W, F, J, M and A

Dimensions are in millimetres

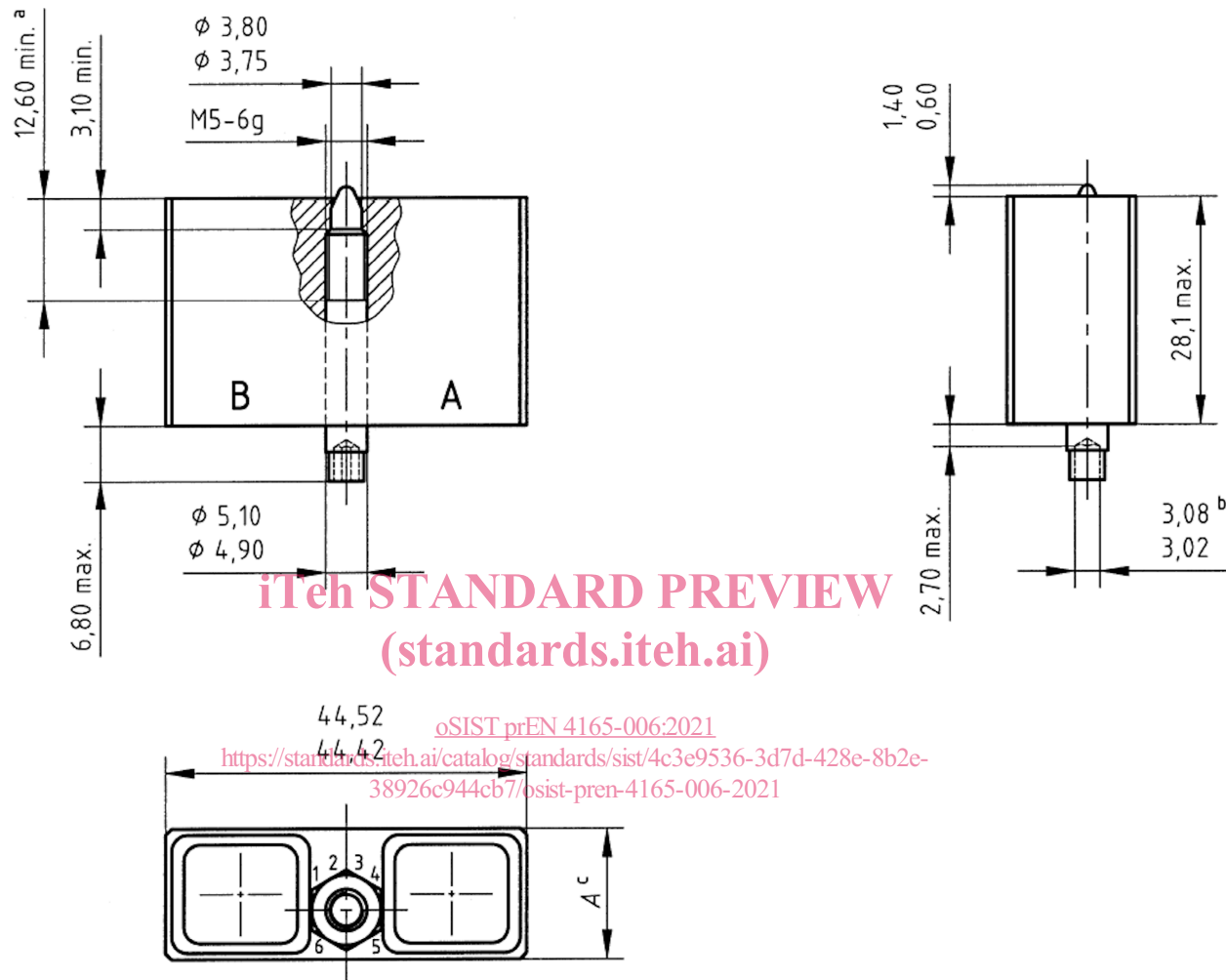

Key

- a Active thread
- b Hexagonal drive
- c See Table 1

Figure 1

Table 1

Class	A max.
W, F, A	15,10
J, M	15,90

5.2 For 4 modules classes W, F, J, M and A

Dimensions are in millimetres

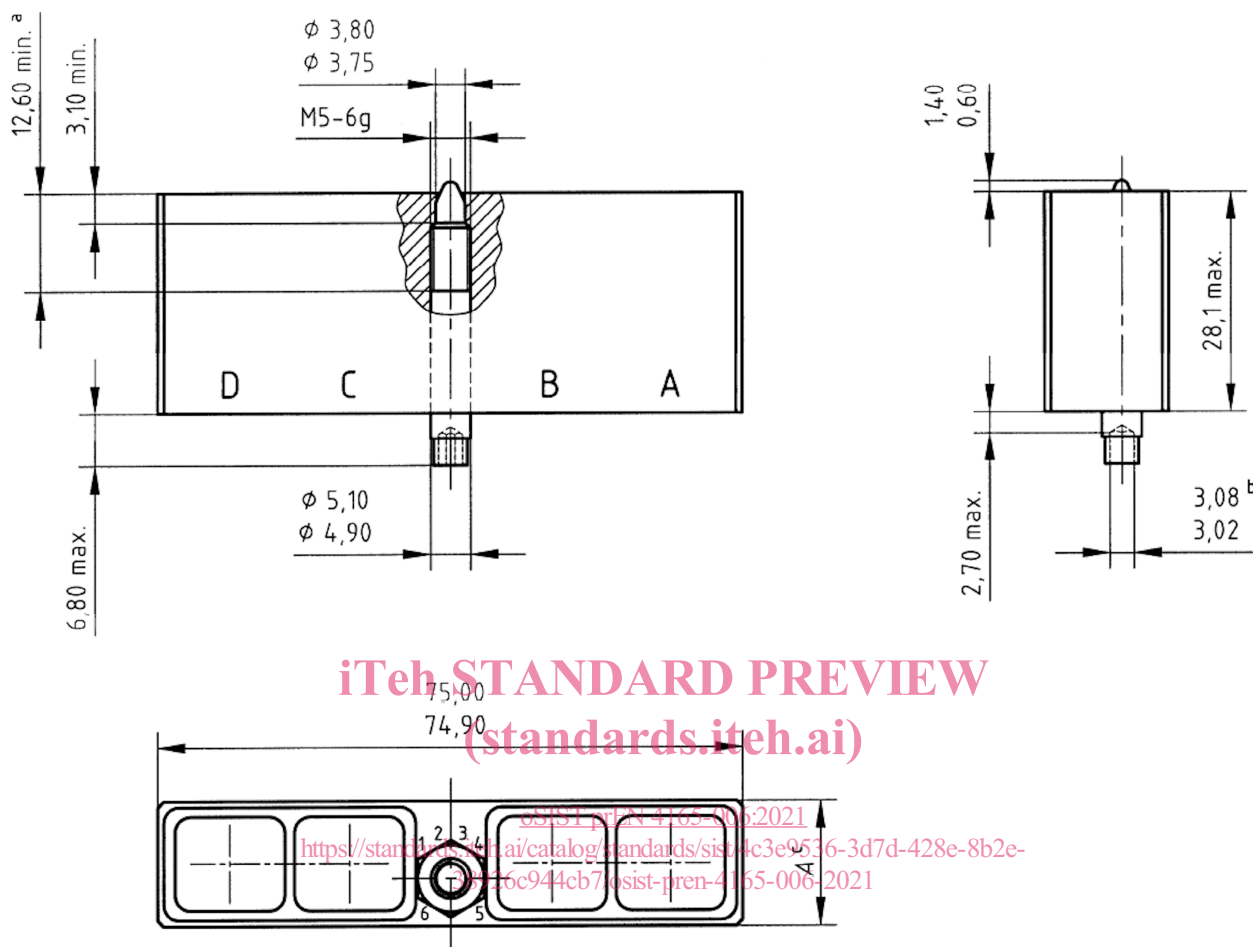

iTeh STANDARD PREVIEW
(standards.iteh.ai)

Key

- a Active thread
- b Hexagonal drive
- c See Table 2

Figure 2

Table 2

Class	A max.
W, F, A	15,10
J, M	15,90

5.3 Plug class

See Table 3.

Table 3

Class	Description
W	Receptacle with housing (shell) olive drab cadmium plated, aluminium alloy, conductive finish, 500 h resistance to salt mist. Rectangular grounding device, or not, maximum operating temperature 175 °C continuous.
F	Plug with housing (shell) black nickel plated, aluminium alloy, 96 hours resistance to salt mist, maximum operating temperature 175 °C continuous.
J	Plug with housing (shell) olive drab cadmium plated, composite material, conductive finish, 500 hours resistance to salt mist, maximum operating temperature 175 °C continuous.
M	Plug with housing (shell) nickel plated, composite material, conductive finish, 500 hours resistance to salt mist, maximum operating temperature 175 °C continuous.
A	Plug with housing (shell) black anodised plated, aluminium alloy, non-conductive finish, 48 hours resistance to salt mist, maximum operating temperature 175 °C continuous.

iTeh STANDARD PREVIEW (standards.iteh.ai)

[oSIST prEN 4165-006:2021](https://standards.iteh.ai/catalog/standards/sist/4c3e9536-3d7d-428e-8b2e-38926c944cb7/osist-pren-4165-006-2021)

<https://standards.iteh.ai/catalog/standards/sist/4c3e9536-3d7d-428e-8b2e-38926c944cb7/osist-pren-4165-006-2021>

prEN 4165-006:2021 (E)

6 Designation

EXAMPLE

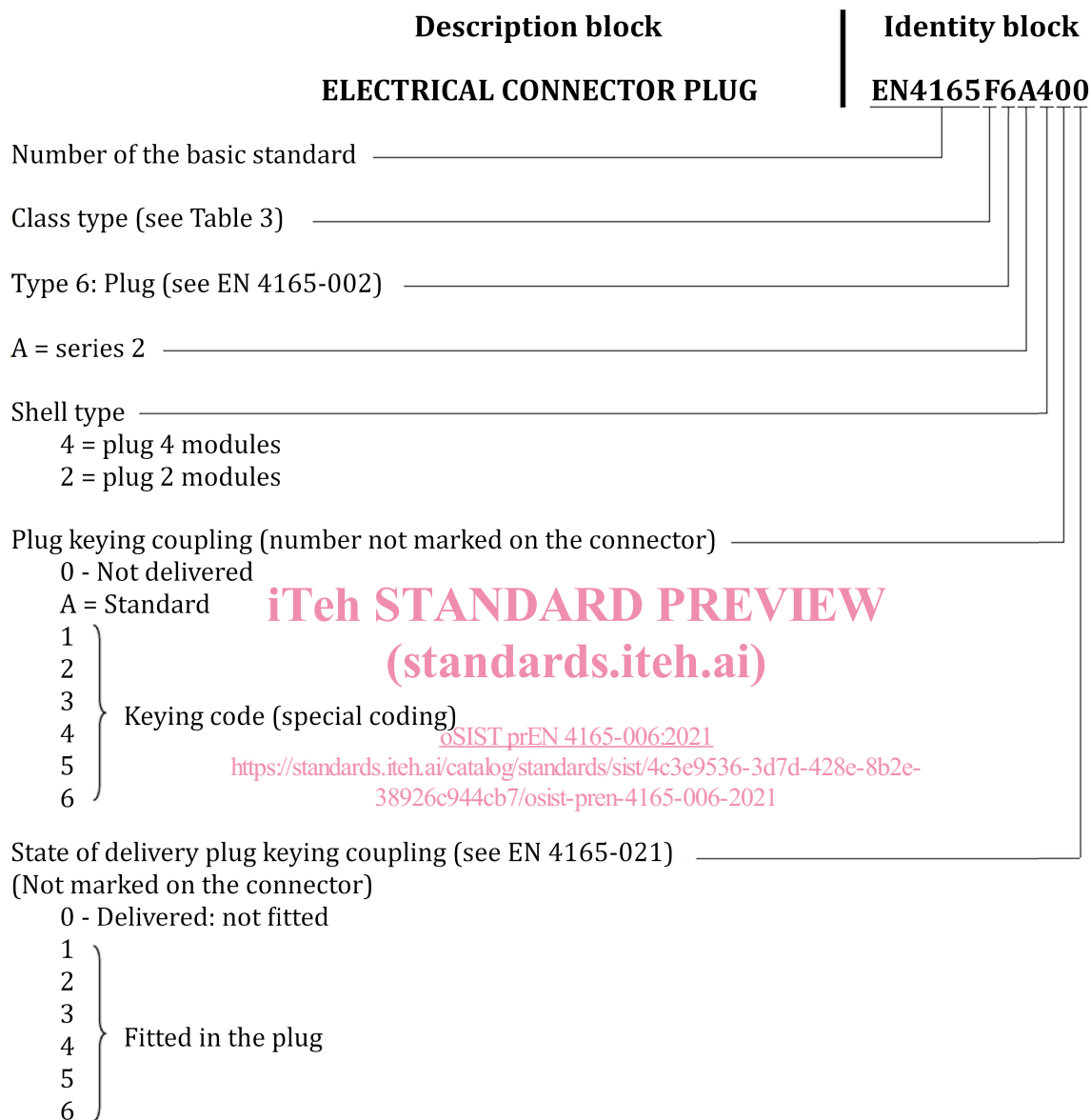

7 Marking

Marking shall include:

- the identity block as defined in Clause 6;
- the date of manufacture (year-week);
- the manufacturer's name or trademark.

8 Technical specification

See EN 4165-001.