



SLOVENSKI STANDARD

SIST ISO 2115:1996

01-junij-1996

Polimerni materiali - Vodne disperzije polimerov in kopolimerov - Določanje temperature pobelitve ("white point") in minimalne temperature tvorbe filma

Plastics -- Polymer dispersions -- Determination of white point temperature and minimum film-forming temperature

iTeh STANDARD PREVIEW

Plastiques -- Dispersions de polymères -- Détermination de la température de point blanc et de la température minimale de la formation de film

[SIST ISO 2115:1996](https://standards.iteh.ai/catalog/standards/sist/b2f500be-7984-488c-9e11-97502b4cfa6a/sist-iso-2115-1996)

Ta slovenski standard je istoveten z: **ISO 2115:1996**

ICS:

83.080.01	Polimerni materiali na splošno	Plastics in general
-----------	--------------------------------	---------------------

SIST ISO 2115:1996

en

iTeh STANDARD PREVIEW
(standards.iteh.ai)

SIST ISO 2115:1996

<https://standards.iteh.ai/catalog/standards/sist/b2f600be-7984-488c-9e11-97502b4cfa6a/sist-iso-2115-1996>

INTERNATIONAL STANDARD

**ISO
2115**

Third edition
1996-02-15

Plastics — Polymer dispersions — Determination of white point temperature and minimum film-forming temperature

iTeh STANDARD PREVIEW
(standards.iteh.ai)

*Plastiques — Dispersions de polymères — Détermination de la
température de point blanc et de la température minimale de la formation
de film*

SIST ISO 2115:1996

<https://standards.iteh.ai/catalog/standards/sist/b2f600be-7984-488c-9e11-97502b4cfa6a/sist-iso-2115-1996>



Reference number
ISO 2115:1996(E)

ISO 2115:1996(E)

Foreword

ISO (the International Organization for Standardization) is a worldwide federation of national standards bodies (ISO member bodies). The work of preparing International Standards is normally carried out through ISO technical committees. Each member body interested in a subject for which a technical committee has been established has the right to be represented on that committee. International organizations, governmental and non-governmental, in liaison with ISO, also take part in the work. ISO collaborates closely with the International Electrotechnical Commission (IEC) on all matters of electrotechnical standardization.

Draft International Standards adopted by the technical committees are circulated to the member bodies for voting. Publication as an International Standard requires approval by at least 75 % of the member bodies casting a vote.

International Standard ISO 2115 was prepared by Technical Committee ISO/TC 61, *Plastics*, Subcommittee SC 9, *Thermoplastic materials*, in close collaboration with ISO/TC 35, *Paints and varnishes*.

This third edition cancels and replaces the second edition (ISO 2115:1976), which has been extended and harmonized, taking account of the requirements of ISO/TC 35, *Paints and varnishes*.

© ISO 1996

All rights reserved. Unless otherwise specified, no part of this publication may be reproduced or utilized in any form or by any means, electronic or mechanical, including photocopying and microfilm, without permission in writing from the publisher.

International Organization for Standardization
Case postale 56 • CH-1211 Genève 20 • Switzerland

Printed in Switzerland

Plastics — Polymer dispersions — Determination of white point temperature and minimum film-forming temperature

1 Scope

This International Standard specifies a method for the determination of the “white point” temperature and the minimum film-forming temperature of polymer dispersions.

2 Normative references

The following standards contain provisions which, through reference in this text, constitute provisions of this International Standard. At the time of publication, the editions indicated were valid. All standards are subject to revision, and parties to agreements based on this International Standard are encouraged to investigate the possibility of applying the most recent editions of the standards indicated below. Members of IEC and ISO maintain registers of currently valid International Standards.

ISO 123:1985, *Rubber latex — Sampling*.

ISO 842:—¹⁾, *Raw materials for paints and varnishes — Sampling*.

ISO 12000:—²⁾, *Plastics/rubber — Polymer dispersions and rubber latices (natural and synthetic) — Definitions and review of test methods*.

3 Definitions

For the purposes of this International Standard, the following definitions apply.

3.1 polymer dispersion: Polymeric material finely dispersed in a liquid phase, which is usually water. During drying, the liquid evaporates and as a result the tiny particles are forced closer together until they touch each other.

Depending on the type of polymer, the temperature and the possible influence of any auxiliaries present, the particles — when spread out in a thin layer on a substrate — interact to form

either

- a discontinuous opaque white mass in which the polymer particles are not fused together if the temperature is insufficient to allow coalescence of the particles;

or

- a continuous transparent layer in which the particles combine to form a homogeneous film if the temperature conditions are sufficient to allow coalescence of the particles.

NOTE 1 Coalescence means uniting of particles at least partly by interpenetration of the polymer chains.

3.2 white point temperature: The temperature limit below which an opaque mass, and above which a transparent film, is formed.

3.3 minimum film-forming temperature: The temperature limit above which a continuous homogeneous film without cracks is observed.

NOTE 2 The white point temperature always lies a few degrees Celsius below the minimum film-forming temperature.

1) To be published. (Revision of ISO 842:1984)

2) To be published.

4 Principle

A polymer dispersion is dried at a suitable temperature gradient with a current of moisture-free air and the temperature at which the coalesced (transparent) section of the film meets the uncoalesced (white) section is determined.

NOTES

3 The required temperature gradient is obtained by applying a hot source and a cold source at some distance from each other to a metal plate (aluminium, stainless steel or copper) which may be either perfectly level and smooth or which may be channelled between the cold source and the hot source.

4 To determine the film-forming temperature, one or more layers, of defined thickness, of the polymer dispersion are spread on the surface of the smooth plate or introduced into the shallow channels (starting at the end nearest the hot source).

5 Apparatus

5.1 Test apparatus (see figure 1 for an example), consisting essentially of a rectangular plate (1)³⁾ which could be made for instance of aluminium, stainless steel or copper, with a thickness sufficient to guarantee a linear temperature gradient. The surface of the plate may either be perfectly smooth and polished or contain several shallow channels (5) — four, for example — 0,3 mm deep⁴⁾.

NOTE 5 To facilitate cleaning, the plate may be covered for instance by a thin aluminium foil (e.g. 0,02 mm thick) which is brushed on smooth with a brush and/or piece of soft felt. A few drops of glycerol between the plate and the foil promote thermal contact.

The required temperature gradient may be achieved by using at one end of the plate a rheostat-controlled electrical resistance (2) as the hot source. At the other end is the cold source, consisting either of an insulated (7) container (3) holding refrigerant or of a coil inserted into the end of the plate and through which refrigerant is circulated.

To measure the temperature gradient of the plate when equilibrium has been reached, the plate is equipped along its edges with evenly spaced holes (4) into which thermometers can be inserted. The first hole (10) shall be positioned at the cold end of the plate at right angles to the beginning of the channels (i.e. the beginning of the layers of dispersion). The last hole shall be near the hot source, with the other holes evenly spaced in between.

The layers of dispersion, or the dispersion in the channels, is dried by directing a slight current of dry air (dried, for example, by passing it through a column packed with calcium chloride) at room temperature over the test sample(s), from the cold end to the hot end.

Provision shall be made for placing a glass cover (6) above the plate, leaving a narrow gap through which the air stream can pass from one end to the other.

5.2 Temperature-measurement devices, with an accuracy of 0,1 °C within the expected temperature range, predominantly between -10 °C and +50 °C. Mercury-in-glass thermometers and thermocouples which can be inserted into the holes in the plate are suitable. Other possibilities are contact or non-contact surface thermometers or salts with defined melting points to determine the temperature gradient of the plate.

5.3 Film applicator or drawdown instrument, made of inert materials such as stainless steel or plastic, capable of producing simultaneously or successively

— films in the channels of a channelled plate (see figure 2)

or

— films about 0,1 mm thick and 20 mm to 25 mm wide on a smooth plate.

NOTE 6 Suitable instruments for determining the white point or the minimum film-forming temperature are available on the market.

6 Procedure

6.1 Establishment of temperature gradient

Put in place the temperature-measurement devices (5.2). Adjust the temperatures of the hot source (2) and the cold source (3) to establish a suitable gradient for the test sample (polymer dispersion), such that:

- the "white point" temperature to be determined occurs in the centre section of the plate;
- the temperature range between the two extreme temperature-measurement devices (that is between the hot and cold source) is between 20 °C and 40 °C and remains constant during the test.

3) Numbers in parentheses are references to parts of the apparatus shown in figure 1.

4) Tests with smooth and channelled plates have given identical results for each of a number of different dispersions.

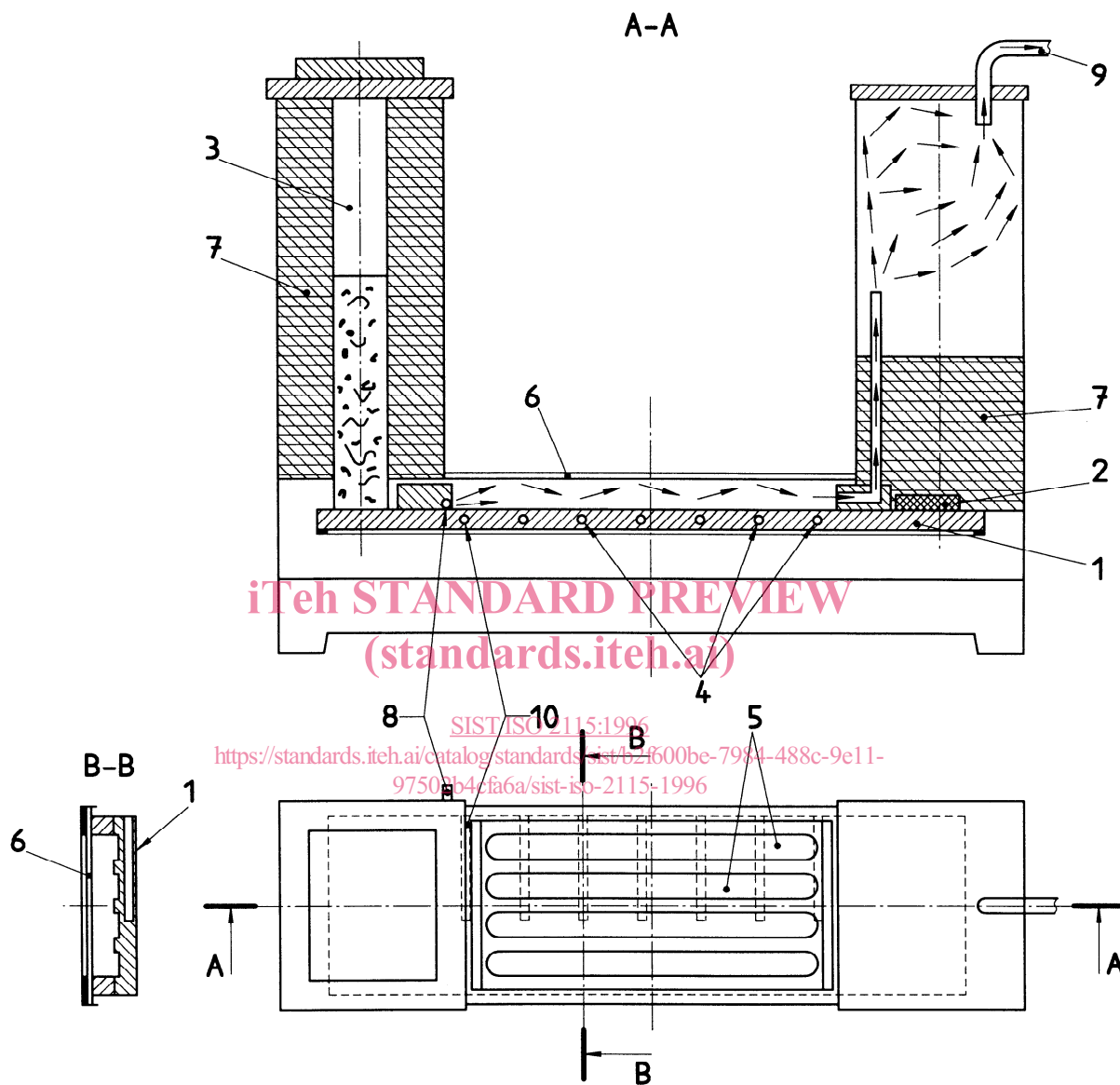
**Key**

- 1 Rectangular metal plate
- 2 Electrical resistance
- 3 Reservoir for refrigerant mixture
- 4 Holes for thermometers (diameter 5 mm)
- 5 Channels in the upper surface of the plate (depth 0,3 mm)
- 6 Glass cover
- 7 Insulating material
- 8 Dry-air inlet
- 9 Air outlet
- 10 First thermometer hole

Figure 1 — Diagram of test apparatus given as an example
(the plate in this diagram is channelled but this feature is not essential)

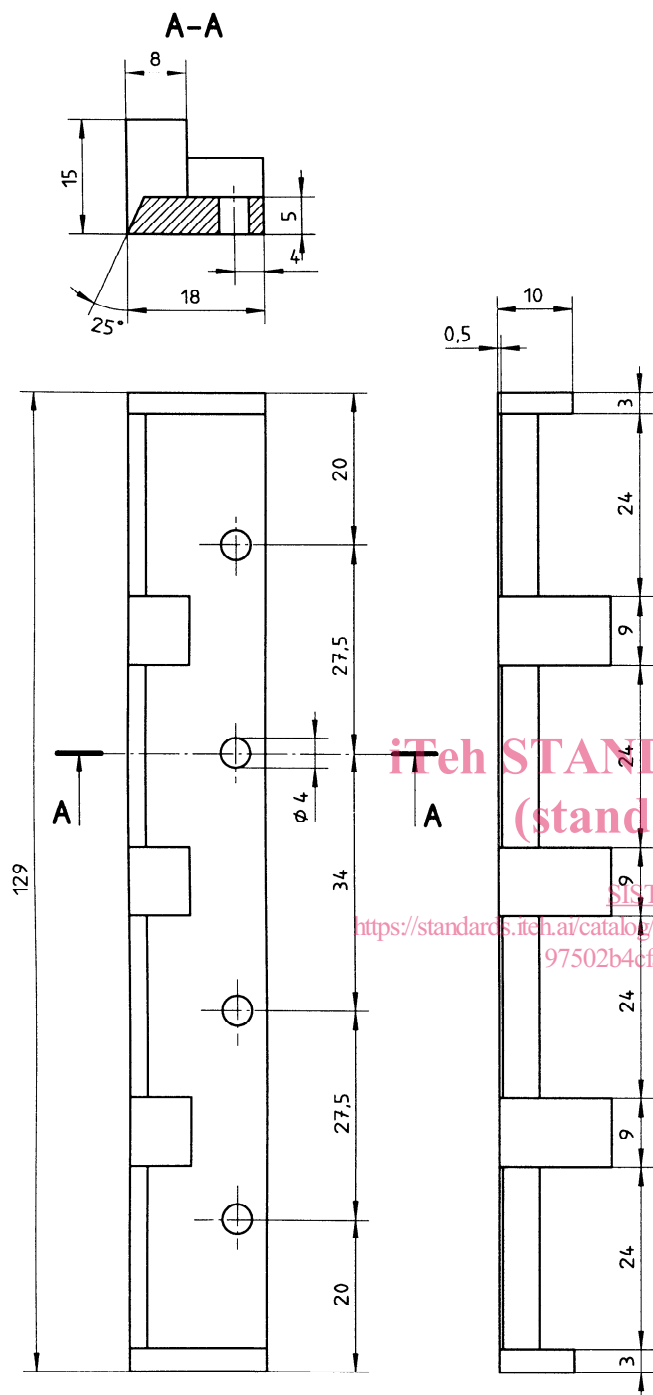

Figure 2 — Example of a film spreader for a channelled plate

The temperature gradient between the two extreme temperature-measurement devices shall be as close as possible to linear, i.e. the temperature differences between successive temperature-measurement devices shall all be of the same order.

The determination can be performed as soon as thermal equilibrium is reached, i.e. when the temperature-measurement devices show no further variation.

6.2 Determination

Apply the test sample (polymer dispersion) in a uniform layer to the top of the plate, starting from the end with the highest temperature.

- In the case of a channelled plate, pour into the channels, at the higher-temperature end, a quantity of the sample slightly in excess of the total capacity of the channels. Spread the material along the channels and remove the surplus with the film applicator.
- In case of a smooth plate, apply strips of the test sample, starting at the higher-temperature end of the plate. Use a film applicator to achieve the desired layer dimensions, i.e. thickness 0,1 mm and width approximately 20 mm to 25 mm.

In both cases, replace the cover (6) and direct under this, from the cold end to the hot end, a current of dry air at room temperature and at a low, constant rate of flow.

Wait until there is complete separation of the section transformed into film (transparent, without cracks) and the non-coalesced section (white). Measure the distance between the first point of temperature measurement (10) and the line of separation.

Note the temperatures indicated by the various temperature-measurement devices in or on the plate. Plot a graph using distance intervals between devices as the abscissae and the plate temperatures as the ordinates.

Determine the temperatures for

- the "white point" (the borderline between the white mass and the transparent film);
- the "minimum film-forming temperature" (the lowest temperature where a continuous, homogeneous film without cracks is formed).

If a surface thermometer is used, the white point and the minimum film-forming temperature can be determined directly by reading the scale of the instrument.

NOTE 7 If the temperature gradient is linear, it is unnecessary to plot a graph since the result would be a straight line.

Carry out the determination at least in duplicate. If the difference between the determinations exceeds 2 °C, discard the results and repeat the test.

7 Expression of results

Record the temperatures obtained from the graphs or directly from the surface thermometer. Calculate the