



Designation: D2838 – 09

Standard Test Method for Shrink Tension and Orientation Release Stress of Plastic Film and Thin Sheeting¹

This standard is issued under the fixed designation D2838; the number immediately following the designation indicates the year of original adoption or, in the case of revision, the year of last revision. A number in parentheses indicates the year of last reapproval. A superscript epsilon (ϵ) indicates an editorial change since the last revision or reapproval.

1. Scope*

1.1 This test method covers the determination of the shrink tension and related characteristics, that is, shrink force and orientation release stress, of heat-shrinkable plastic film and sheeting of less than 1.0 mm (0.04 in.) thickness. Two procedures are described that permit the measurement of shrink forces at predetermined temperatures. They are as follows:

1.1.1 *Procedure A* is designed to measure the maximum force exerted by a specimen that is totally restrained from shrinking as it is heated rapidly to a specific temperature.

1.1.2 *Procedure B* is designed to measure the maximum force exerted by a specimen that is permitted to shrink a predetermined amount prior to restraint while being heated rapidly to a specific temperature.

1.2 Orientation release stress can be determined from the data obtained using Procedure A.

1.3 The values stated in SI units are to be regarded as the standard. The values in parentheses are for information only.

1.4 *This standard does not purport to address all of the safety concerns, if any, associated with its use. It is the responsibility of the user of this standard to establish appropriate safety and health practices and determine the applicability of regulatory limitations prior to use.*

NOTE 1—Film has been arbitrarily defined as sheeting having nominal thickness not greater than 0.25 μm (0.010 in.).

NOTE 2—There is no known ISO equivalent to this test method.

2. Referenced Documents

2.1 ASTM Standards:²

D618 Practice for Conditioning Plastics for Testing

D883 Terminology Relating to Plastics

¹ This test method is under the jurisdiction of ASTM Committee D20 on Plastics and is the direct responsibility of Subcommittee D20.19 on Film, Sheeting, and Molded Products.

Current edition approved May 1, 2009. Published June 2009. Originally approved in 1969. Last previous edition approved in 2008 as D2838 - 08. DOI: 10.1520/D2838-09.

² For referenced ASTM standards, visit the ASTM website, www.astm.org, or contact ASTM Customer Service at service@astm.org. For *Annual Book of ASTM Standards* volume information, refer to the standard's Document Summary page on the ASTM website.

D4000 Classification System for Specifying Plastic Materials

D5947 Test Methods for Physical Dimensions of Solid Plastics Specimens

D6287 Practice for Cutting Film and Sheeting Test Specimens

D6988 Guide for Determination of Thickness of Plastic Film Test Specimens

E2251 Specification for Liquid-in-Glass ASTM Thermometers with Low-Hazard Precision Liquids

3. Terminology

3.1 Definitions of Terms Specific to This Standard:

3.1.1 *orientation release stress, n*—the maximum shrink tension developed by a film in a specified direction throughout its range of shrink temperatures while totally restrained from shrinking.

3.1.2 *shrink force, n*—the force per original unit width developed by a film in a specified direction and at a specified temperature in its attempt to shrink while under restraint.

3.1.3 *shrink tension, n*—the force per original average cross-sectional area developed by a film in a specified direction and at a specified temperature in its attempt to shrink while under restraint.

3.2 Definitions:

3.2.1 For definitions of terms used in this test method, refer to Terminology D883.

4. Summary of Test Method

4.1 A 25.4-mm (1-in.) wide strip of film or sheeting is clamped in the arms of a shrink tension holder (see Fig. 1), one arm of which contains a strain gage. The holder is immersed in a hot bath and the force exerted by the film is measured by the strain gage. The data is collected by a data acquisition device. The tests may be carried out with or without free shrinkage of the material before restraint.

5. Significance and Use

5.1 As a result of the manufacturing process, internal stresses are locked into the film and these can be released by heating. For any given type of film or sheeting, the temperatures at which shrinkage will begin are related to processing

*A Summary of Changes section appears at the end of this standard

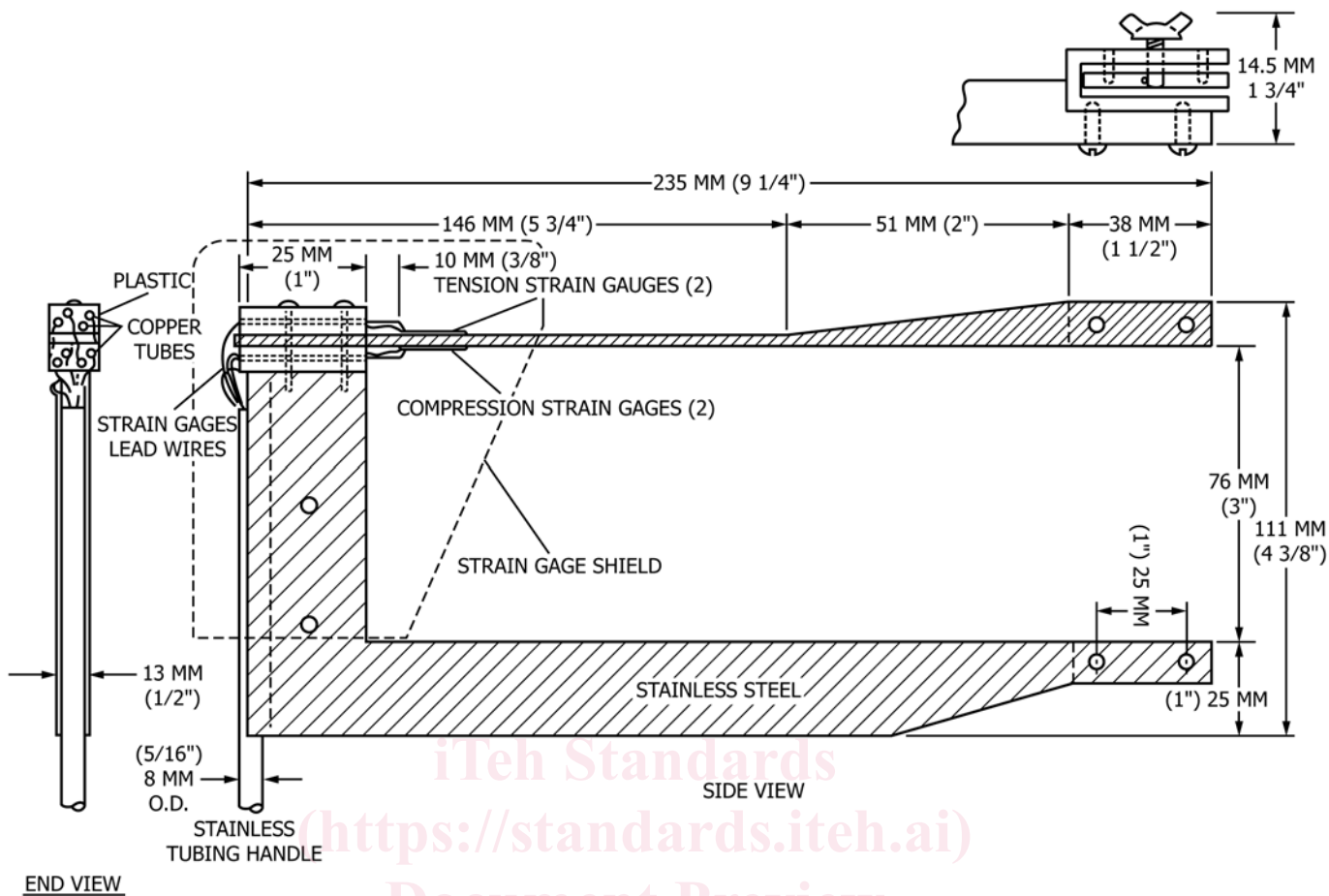

FIG. 1 Design for Shrink Tension Holder

techniques employed to manufacture the film and also may be related to a phase transition in the base resin.

5.2 Shrink tension affects the appearance and performance of a film in a shrink-packaging application. It may also be used to determine the degree and direction of orientation. The orientation exerts a great influence upon important physical characteristics such as tensile strength, stiffness, tear resistance, and impact strength.

5.3 Data from Procedure A are most useful for determining the degree and direction of orientation, orientation release stress, and the maximum force that the film can exert at a given temperature.

5.4 Since, in actual applications, film is seldom, if ever, totally restrained, data from Procedure B are useful in estimating the force an item to be packaged will actually receive and in predicting the appearance of packaged items.

5.5 The characterization of shrink tension as a function of temperature, and the resultant determination of orientation release stress and its corresponding temperature, is usually carried out only for a particular material of specified thickness for a defined fabrication process. For product development purposes, quality control and determination of conformity to specification limits, the measurement of shrink tension at only one or two specified temperatures is normally sufficient.

5.6 Before proceeding with this test method, reference shall be made to the specification of the material being tested. Any test specimen preparation, conditioning, dimensions, or testing parameters, or combination thereof, covered in the relevant ASTM material specification shall take precedence over those mentioned in this test method. If there are no relevant ASTM material specifications, then the default conditions apply. Table 1 of Classification Systems D4000 lists the ASTM material specifications that currently exist

6. Apparatus

6.1 *Shrink Tension Holder*³—A suggested design is portrayed in Fig. 1 and Fig. 2.

6.2 *Strain Gage Conditioner*; four-arm bridge, preferable.

6.3 *Data Acquisition Device*— Electronic, digital or chart recorder pen having a response of no more than 30 ms from 10 to 90 % of full-scale deflection, chart width of at least 100 mm is preferable.

³ The sole source of supply of the Shrink Tension Holder known to the committee at this time is Standard Scientific Supply Company, 105 West Butternut Road, Hellertown, PA 180555, ph: 610-838-7500. If you are aware of alternative suppliers, please provide this information to ASTM International Headquarters. Your comments will receive careful consideration at a meeting of the responsible technical committee,¹ which you may attend.