



SLOVENSKI STANDARD
oSIST prEN ISO 7886-3:2019
01-julij-2019

Sterilne podkožne injekcijske brizge za enkratno uporabo - 3. del: Brizge za točno določen odmerek imunizacije s sistemom za samouničenje (ISO/DIS 7886-3:2019)

Sterile hypodermic syringes for single use - Part 3: Auto-disabled syringes for fixed-dose immunization (ISO/DIS 7886-3:2019)

Sterile Einmalspritzen für medizinische Zwecke - Teil 3: Selbstblockierende Spritzen für die Injektion mit fixer Impfstoffdosis (ISO/DIS 7886-3:2019)

Seringues hypodermiques stériles, non réutilisables - Partie 3: Seringues autobloquantes pour vaccination à dose fixe (ISO/DIS 7886-3:2019)

Ta slovenski standard je istoveten z: prEN ISO 7886-3

ICS:

11.040.25	Injekcijske brizge, igle in katetri	Syringes, needles and catheters
-----------	-------------------------------------	---------------------------------

oSIST prEN ISO 7886-3:2019

en

DRAFT INTERNATIONAL STANDARD

ISO/DIS 7886-3

ISO/TC 84

Secretariat: DS

Voting begins on:
2019-05-17Voting terminates on:
2019-08-09

Sterile hypodermic syringes for single use —

Part 3: Auto-disabled syringes for fixed-dose immunization

*Seringues hypodermiques stériles, non réutilisables —**Partie 3: Seringues autobloquantes pour vaccination à dose fixe*

ICS: 11.040.25

iTeh STANDARD PREVIEW
(standards.iteh.ai)

SIST EN ISO 7886-3:2020

<https://standards.iteh.ai/catalog/standards/sist/fbb1bd81-6f8f-45f4-93c9-4e2568b0e638/sist-en-iso-7886-3-2020>

THIS DOCUMENT IS A DRAFT CIRCULATED FOR COMMENT AND APPROVAL. IT IS THEREFORE SUBJECT TO CHANGE AND MAY NOT BE REFERRED TO AS AN INTERNATIONAL STANDARD UNTIL PUBLISHED AS SUCH.

IN ADDITION TO THEIR EVALUATION AS BEING ACCEPTABLE FOR INDUSTRIAL, TECHNOLOGICAL, COMMERCIAL AND USER PURPOSES, DRAFT INTERNATIONAL STANDARDS MAY ON OCCASION HAVE TO BE CONSIDERED IN THE LIGHT OF THEIR POTENTIAL TO BECOME STANDARDS TO WHICH REFERENCE MAY BE MADE IN NATIONAL REGULATIONS.

RECIPIENTS OF THIS DRAFT ARE INVITED TO SUBMIT, WITH THEIR COMMENTS, NOTIFICATION OF ANY RELEVANT PATENT RIGHTS OF WHICH THEY ARE AWARE AND TO PROVIDE SUPPORTING DOCUMENTATION.

This document is circulated as received from the committee secretariat.

ISO/CEN PARALLEL PROCESSING



Reference number
ISO/DIS 7886-3:2019(E)

© ISO 2019

iTeh STANDARD PREVIEW (standards.iteh.ai)

SIST EN ISO 7886-3:2020

<https://standards.iteh.ai/catalog/standards/sist/fbb1bd81-6f8f-45f4-93c9-4e2568b0e638/sist-en-iso-7886-3-2020>



COPYRIGHT PROTECTED DOCUMENT

© ISO 2019

All rights reserved. Unless otherwise specified, or required in the context of its implementation, no part of this publication may be reproduced or utilized otherwise in any form or by any means, electronic or mechanical, including photocopying, or posting on the internet or an intranet, without prior written permission. Permission can be requested from either ISO at the address below or ISO's member body in the country of the requester.

ISO copyright office
CP 401 • Ch. de Blandonnet 8
CH-1214 Vernier, Geneva
Phone: +41 22 749 01 11
Fax: +41 22 749 09 47
Email: copyright@iso.org
Website: www.iso.org

Published in Switzerland

Contents

	Page
Foreword	v
Introduction	vi
1 Scope	1
2 Normative references	1
3 Terms and definitions	2
4 Nomenclature	2
5 General requirements	3
6 Extraneous matter	4
7 Limits for acidity or alkalinity	4
8 Limits for extractable metals	4
9 Lubricant	4
10 Tolerance on nominal capacity	4
11 Graduated scale	5
11.1 Scale.....	5
11.2 Position of scale.....	5
12 Barrel	5
12.1 Dimensions.....	5
12.2 Barrel flanges.....	5
13 Plunger stopper/plunger assembly	5
13.1 Design.....	5
13.2 Fit of the plunger stopper/plunger in the barrel.....	6
13.3 Fiducial line.....	6
14 Needle	6
14.1 General.....	6
14.2 Integrated needle.....	6
14.3 Non-integrated needle.....	6
14.4 Sharps protection features.....	6
15 Performance	6
15.1 General.....	6
15.2 Dead space.....	6
15.3 Freedom from air and liquid leakage.....	7
15.4 Auto-disable feature.....	7
15.5 Performance after shipping.....	7
16 Packaging	7
16.1 Unit packaging providing sterile barrier.....	7
16.2 Multiple unit pack.....	7
16.3 User packaging.....	7
17 Information supplied by the manufacturer	8
17.1 General.....	8
17.2 Syringes.....	8
17.3 Unit packaging providing sterile barrier.....	8
17.4 The user packaging shall bear at least the following information:.....	8
17.5 Storage containers.....	9
17.6 Transport wrapping.....	9
Annex A (normative) Method for preparation of extracts	11
Annex B (informative) Test method for forces required to operate piston	12

ISO/DIS 7886-3:2019(E)

Annex C (normative) Test method for testing auto-disable feature	14
Bibliography	15

iTeh STANDARD PREVIEW
(standards.iteh.ai)

SIST EN ISO 7886-3:2020

<https://standards.iteh.ai/catalog/standards/sist/fbb1bd81-6f8f-45f4-93c9-4e2568b0e638/sist-en-iso-7886-3-2020>

Foreword

ISO (the International Organization for Standardization) is a worldwide federation of national standards bodies (ISO member bodies). The work of preparing International Standards is normally carried out through ISO technical committees. Each member body interested in a subject for which a technical committee has been established has the right to be represented on that committee. International organizations, governmental and non-governmental, in liaison with ISO, also take part in the work. ISO collaborates closely with the International Electrotechnical Commission (IEC) on all matters of electrotechnical standardization.

The procedures used to develop this document and those intended for its further maintenance are described in the ISO/IEC Directives, Part 1. In particular, the different approval criteria needed for the different types of ISO documents should be noted. This document was drafted in accordance with the editorial rules of the ISO/IEC Directives, Part 2 (see www.iso.org/directives).

Attention is drawn to the possibility that some of the elements of this document may be the subject of patent rights. ISO shall not be held responsible for identifying any or all such patent rights. Details of any patent rights identified during the development of the document will be in the Introduction and/or on the ISO list of patent declarations received (see www.iso.org/patents).

Any trade name used in this document is information given for the convenience of users and does not constitute an endorsement.

For an explanation of the voluntary nature of standards, the meaning of ISO specific terms and expressions related to conformity assessment, as well as information about ISO's adherence to the World Trade Organization (WTO) principles in the Technical Barriers to Trade (TBT), see www.iso.org/iso/foreword.html.

This document was prepared by Technical Committee ISO/TC 84, *Devices for administration of medicinal products and catheters*.

This second edition cancels and replaces the first edition (ISO 7886-3:2005), which has been technically revised.

The main changes compared to the previous edition are as follows:

- updated references to other standards, mainly to the new version of ISO 7886-1:2017.

A list of all parts in the ISO 7886- series can be found on the ISO website.

Any feedback or questions on this document should be directed to the user's national standards body. A complete listing of these bodies can be found at www.iso.org/members.html.

ISO/DIS 7886-3:2019(E)

Introduction

ISO 7886 was first published in 1984. It was subsequently decided to divide it into two parts: ISO 7886-1 retaining essentially the scope of ISO 7886:1984, and ISO 7886-2 being applicable to sterile, single-use syringes for use with power-driven pumps.

The preparation of this document was recognized as a high priority requirement to prevent the re-use of fixed dose immunization syringes in the developing and transitional countries. Re-use of injection equipment in the absence of sterilization has increasingly led to transmission of blood-borne pathogens.

The World Health Organization (WHO) had produced a specification for syringes that are rendered inactive after one use (commonly referred to as “auto-disabled” syringes). Both the WHO and ISO agreed that an additional part of ISO 7886 would be required to cover “auto-disabled” syringes, while leaving in place ISO 7886-1 and ISO 7886-2 without modification, as a large number of devices in common use would not be intended to comply with the auto-disable properties suggested.

This document is intended to cover “fixed dose” immunization syringes that are passively rendered non-reusable for another application after the commencement of injection intended to deliver a nominal vaccine dose. These syringes are not covered by ISO 7886-1 and ISO 7886-2.

It has been discussed to limit the syringe types to only comprise the type having an auto-disable feature that is automatically activated and remains effective from the time that the injection is commenced. A risk assessment based only on hypothetical perception that the type having an auto-disable feature that is automatically activated and remains effective from the time of the injection being initiated is potentially safer than the other types. However, no consensus could be reached on either deleting types or retaining them as no reliable risk data from field use exist at present. It was therefore agreed to retain all types and restrict this revision to alignment with the recent version of ISO 7886-1 and initiate a new revision if new field studies or incidents reports indicate a need for a revision.

It is recognized that syringes designed to reduce the risk of needle stick injuries may also comply with this document with regard to their auto-disable properties, but it is stressed that needle stick protection features of syringes are not in themselves addressed in this document. Requirements for sharps injury protection features are covered by ISO 23908.

In some countries national regulations are legally binding and the requirements may take precedence over this document.

Guidance on transition periods for implementing the requirements of this document is given in ISO/TR 19244.

Sterile hypodermic syringes for single use —

Part 3: Auto-disabled syringes for fixed-dose immunization

1 Scope

This document specifies the properties and performance of sterile single-use hypodermic syringes with or without needle, made of plastic, rubber or other materials and intended for the filling and the injection of vaccines immediately after filling. Upon delivering a fixed dose of vaccine, the syringe is automatically rendered unusable.

This document does not specify the design of the auto-disable feature, which is left to the discretion of the manufacturer.

This document is not applicable to syringes for use with insulin (specified in ISO 8537), syringes for use with power-driven syringe pumps (specified in ISO 7886-2), reuse prevention syringes (specified in ISO 7886-4) and syringes designed to be prefilled. It does not address compatibility with injection fluids/vaccines.

NOTE Prefilled syringes are covered in the ISO 11040- series.

2 Normative references

The following documents are referred to in the text in such a way that some or all of their content constitutes requirements of this document. For dated references, only the edition cited applies. For undated references, the latest edition of the referenced document (including any amendments) applies.

ISO 7000, *Graphical symbols for use on equipment — Registered symbols*

ISO 7864:2016, *Sterile hypodermic needles for single use — Requirements and test methods*

ISO 7886-1:2017, *Sterile hypodermic syringes for single use — Part 1: Syringes for manual use*

ISO 8537:2016, *Sterile single-use syringes, with or without needle, for insulin*

ISO 9626, *Stainless steel needle tubing for the manufacture of medical devices — Requirements and test methods*

ISO 10993-1, *Biological evaluation of medical devices — Part 1: Evaluation and testing within a risk management process*

ISO 14971, *Medical devices — Application of risk management to medical devices*

ISO 15223-1, *Medical devices — Symbols to be used with medical device labels, labelling and information to be supplied — Part 1: General requirements*

ISO 23908, *Sharps injury protection — Requirements and test methods — Sharps protection features for single-use hypodermic needles, introducers for catheters and needles used for blood sampling*

ISO 80369-7, *Small-bore connectors for liquids and gases in healthcare applications — Part 7: Connectors for intravascular or hypodermic applications*

ASTM D999-01, *Standard methods for vibration testing of shipping containers*

ASTM D5276-98, *Standard test method for drop test of loaded containers by free fall*

ISO/DIS 7886-3:2019(E)

3 Terms and definitions

For the purposes of this document, the terms and definitions given in ISO 7886-1 and ISO 8537 and the following apply.

ISO and IEC maintain terminological databases for use in standardization at the following addresses:

- ISO Online browsing platform: available at <https://www.iso.org/obp>
- IEC Electropedia: available at <http://www.electropedia.org/>

3.1

auto-disable syringe feature

feature that passively activates upon delivering injection of the nominal fixed dose to prevent subsequent re-use of the syringe and the needle

3.2

passive action

activation of the reuse prevention feature that does not require an additional step by the user, separate from any action needed to perform the primary intended injection function of the device

3.3

active activation

activation of the reuse prevention feature that does require an additional step by the user

3.4

normal conditions of use

operation of the device by any user according to its instructions for use

3.5

integrated needle

stainless steel cannula that is directly bonded into the barrel of the syringe

3.6

non-integrated needle

a hypodermic needle that is attached by the user prior to making an injection

3.7

barrel flanges

flanges that protrude from the barrel (also referred to as finger grips) to provide the user a means of gripping the syringe during injection

3.8

needle cap or shield

sheath intended to physically protect the needle prior to use

4 Nomenclature

The nomenclature for components of auto-disable syringes for fixed dose is shown in [Figure 1](#).

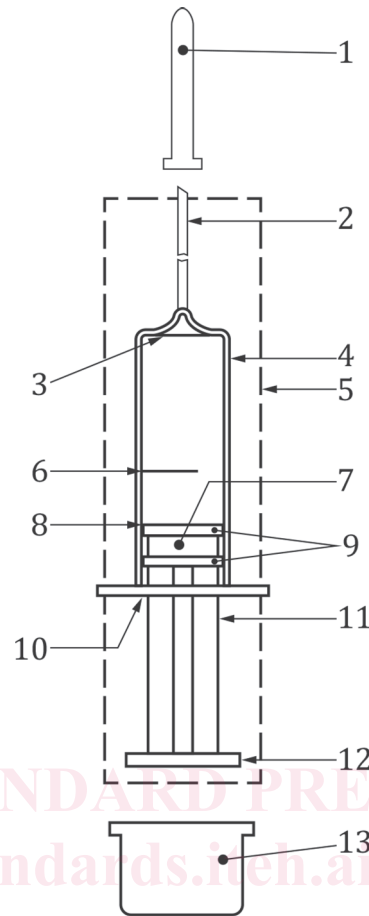
**Key**

1	needle cap or shield (if used)	8	fiducial line
2	needle	9	seal(s)
3	zero line	10	barrel flanges (finger grips)
4	barrel	11	plunger
5	auto-disable feature	12	push-button
6	nominal capacity line	13	plunger cap (if used)
7	plunger stopper		

NOTE The drawing is intended to be illustrative of components of an auto-disabled syringe only.

Figure 1 — Schematic representation of auto-disabled syringe for fixed dose

5 General requirements

The general requirements listed below are considered to be design input for manufacturers:

- a) syringes shall be free from defects affecting appearance, safety and serviceability for their intended use. The syringe's barrel flanges shall be of adequate size, shape and strength for the intended purpose. The design specifications for the barrel flanges shall be determined through risk analysis and confirmed through usability validation testing. The materials shall not cause the syringes to yield, under conditions of normal use, significant amounts of toxic substances and shall permit them to satisfy the appropriate national requirements or regulations for freedom from pyrogenic materials and abnormal toxicity. Materials used in the construction of the wall of the syringe barrel shall have sufficient clarity to enable dosages to be read without difficulty. This document does not specify materials to be used for the construction and lubrication of the device, because their