

---

---

**Metallic powders — Determination of  
apparent density —**

**Part 1:  
Funnel method**

*Poudres métalliques — Détermination de la masse volumique  
apparente —*

**iTeh STANDARD PREVIEW**  
*Partie 1: Méthode de l'entonnoir*  
**(standards.iteh.ai)**

[ISO 3923-1:2018](https://standards.iteh.ai/catalog/standards/sist/451194b5-6936-480f-b226-93d61a8fc60c/iso-3923-1-2018)

<https://standards.iteh.ai/catalog/standards/sist/451194b5-6936-480f-b226-93d61a8fc60c/iso-3923-1-2018>



**iTeh STANDARD PREVIEW**  
**(standards.iteh.ai)**

ISO 3923-1:2018

<https://standards.iteh.ai/catalog/standards/sist/451194b5-6936-480f-b226-93d61a8fc60c/iso-3923-1-2018>



**COPYRIGHT PROTECTED DOCUMENT**

© ISO 2018

All rights reserved. Unless otherwise specified, or required in the context of its implementation, no part of this publication may be reproduced or utilized otherwise in any form or by any means, electronic or mechanical, including photocopying, or posting on the internet or an intranet, without prior written permission. Permission can be requested from either ISO at the address below or ISO's member body in the country of the requester.

ISO copyright office  
CP 401 • Ch. de Blandonnet 8  
CH-1214 Vernier, Geneva  
Phone: +41 22 749 01 11  
Fax: +41 22 749 09 47  
Email: [copyright@iso.org](mailto:copyright@iso.org)  
Website: [www.iso.org](http://www.iso.org)

Published in Switzerland

# Contents

	Page
Foreword .....	iv
<b>1 Scope</b> .....	<b>1</b>
<b>2 Normative references</b> .....	<b>1</b>
<b>3 Terms and definitions</b> .....	<b>1</b>
<b>4 Principle</b> .....	<b>1</b>
<b>5 Symbols and designations</b> .....	<b>1</b>
<b>6 Apparatus</b> .....	<b>2</b>
<b>7 Sample</b> .....	<b>3</b>
<b>8 Procedure</b> .....	<b>3</b>
<b>9 Expression of results</b> .....	<b>4</b>
<b>10 Precision</b> .....	<b>4</b>
10.1 Repeatability .....	4
10.2 Reproducibility .....	4
<b>11 Test report</b> .....	<b>4</b>
<b>Annex A (normative) Carney funnel</b> .....	<b>5</b>
<b>Bibliography</b> .....	<b>6</b>

**iTeh STANDARD PREVIEW**  
(standards.iteh.ai)

[ISO 3923-1:2018](https://standards.iteh.ai/catalog/standards/sist/451194b5-6936-480f-b226-93d61a8fc60c/iso-3923-1-2018)

<https://standards.iteh.ai/catalog/standards/sist/451194b5-6936-480f-b226-93d61a8fc60c/iso-3923-1-2018>

## Foreword

ISO (the International Organization for Standardization) is a worldwide federation of national standards bodies (ISO member bodies). The work of preparing International Standards is normally carried out through ISO technical committees. Each member body interested in a subject for which a technical committee has been established has the right to be represented on that committee. International organizations, governmental and non-governmental, in liaison with ISO, also take part in the work. ISO collaborates closely with the International Electrotechnical Commission (IEC) on all matters of electrotechnical standardization.

The procedures used to develop this document and those intended for its further maintenance are described in the ISO/IEC Directives, Part 1. In particular the different approval criteria needed for the different types of ISO documents should be noted. This document was drafted in accordance with the editorial rules of the ISO/IEC Directives, Part 2 (see [www.iso.org/directives](http://www.iso.org/directives)).

Attention is drawn to the possibility that some of the elements of this document may be the subject of patent rights. ISO shall not be held responsible for identifying any or all such patent rights. Details of any patent rights identified during the development of the document will be in the Introduction and/or on the ISO list of patent declarations received (see [www.iso.org/patents](http://www.iso.org/patents)).

Any trade name used in this document is information given for the convenience of users and does not constitute an endorsement.

For an explanation on the voluntary nature of standards, the meaning of ISO specific terms and expressions related to conformity assessment, as well as information about ISO's adherence to the World Trade Organization (WTO) principles in the Technical Barriers to Trade (TBT) see the following URL: [www.iso.org/iso/foreword.html](http://www.iso.org/iso/foreword.html). (standards.iteh.ai)

This document was prepared by Technical Committee ISO/TC 119, *Powder metallurgy*, Subcommittee SC 2, *Sampling and testing methods for powders (including powders for hard metals)*.  
<https://standards.iteh.ai/catalog/standards/sist/451194b5-6936-480f-b226-12461a15603d/iso-3923-1-2018>

This fourth edition, which cancels and replaces the third edition (ISO 3923-1:2008), has been updated with the funnel used in the Gustavsson method. Also, the figures showing the funnels have been removed and instead references are made to the relevant test method standards.

A list of all the parts in the ISO 3923 series can be found on the ISO website.

# Metallic powders — Determination of apparent density —

## Part 1: Funnel method

### 1 Scope

This document specifies the funnel method for the determination of the apparent density of metallic powders under standardized conditions.

The method is intended for metallic powders that flow freely through a 2,5 mm diameter orifice. It can, however, be used for powders that flow with difficulty through a 2,5 mm diameter orifice but flow through a 5 mm diameter orifice.

Methods for the determination of the apparent density of powders that will not flow through a 5 mm diameter orifice are specified in ISO 3923-2[1].

### 2 Normative references

The following documents are referred to in the text in such a way that some or all of their content constitutes requirements of this document. For dated references, only the edition cited applies. For undated references, the latest edition of the referenced document (including any amendments) applies.

ISO 4490, *Metallic powders — Determination of flow rate by means of a calibrated funnel (Hall flowmeter)*

ISO 13517, *Metallic powders — Determination of flow rate by means of a calibrated funnel (Gustavsson flowmeter)*

### 3 Terms and definitions

No terms and definitions are listed in this document.

ISO and IEC maintain terminological databases for use in standardization at the following addresses:

- ISO Online browsing platform: available at <https://www.iso.org/obp>
- IEC Electropedia: available at <http://www.electropedia.org/>

### 4 Principle

Measurement of the mass of a certain quantity of powder, which in a loose condition exactly fills a cup of known volume.

The loose condition is obtained by using, when filling the cup, a funnel placed at a determined distance above the cup.

The ratio between the mass and the volume represents the apparent density.

### 5 Symbols and designations

The symbols and designations used in this document are defined in [Table 1](#).

Table 1

Symbol	Designation	Unit
$\rho_a$	Apparent density of metallic powders (general term)	g/cm <sup>3</sup>
$\rho_{ac}$	Apparent density obtained by the funnel method	g/cm <sup>3</sup>
$m$	Mass of the powder	g
$V$	Volume of the cup	cm <sup>3</sup>

## 6 Apparatus

### 6.1 Funnels accepted have the following properties:

- orifice of diameter 2,5 mm and a cone angle of 60°, Hall funnel according to ISO 4490;
- orifice of diameter 2,5 mm and a cone angle of 30°, Gustavsson funnel according to ISO 13517;
- orifice of diameter 5,0 mm and cone angle of 60°, Carney funnel according to [Annex A](#).

**6.2 Cylindrical cup**, with a capacity of 25 cm<sup>3</sup> ± 0,03 cm<sup>3</sup> and an internal diameter of 28 mm ± 0,5 mm. A cup with the same capacity and with an internal diameter of 30 mm ± 1 mm is also acceptable. 28 mm ± 0,5 mm is, however, the first option when new equipment is manufactured.

The cup and funnels should be made of a non-magnetic, corrosion-resistant, metallic material with sufficient wall thickness and hardness to avoid distortion and excessive wear. The inner surfaces of the cup and funnels should be polished.

**6.3 Balance**, of sufficient capacity, capable of weighing the test sample to an accuracy of ± 0,01 g.

**6.4 Stand and horizontal vibration-free base**, to support the cup and funnel, the stand holding the orifice of the funnel 25 ± 0,5 mm above the top surface of the cup and coaxially with it (see [Figure 1](#)).

Dimensions in millimetres

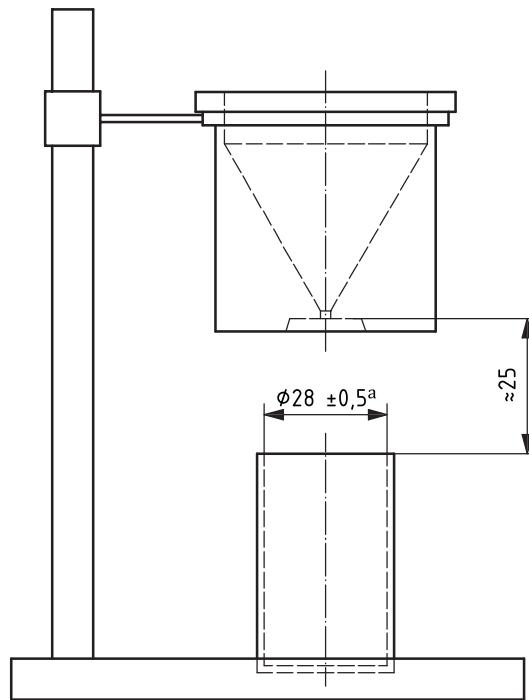

- <sup>a</sup> A cup with the same capacity and with an internal diameter of 30 mm  $\pm$  1 mm is also acceptable (see 6.2).

**Figure 1 — Arrangement of the stand with funnel and cup**

ISO 3923-1:2018

<https://standards.iteh.ai/catalog/standards/sist/451194b5-6936-480fb226-93d61a8fc60c/iso-3923-1-2018>

## 7 Sample

**7.1** The test sample shall be at least 100 cm<sup>3</sup> in volume to allow the determination to be carried out on three test portions.

**7.2** In general, the powder should be tested in the as-received condition. In certain instances, the powder may be dried. However, if the powder is susceptible to oxidation, the drying shall take place in a vacuum or in an inert gas. If the powder contains volatile substances, it shall not be dried.

## 8 Procedure

**8.1** Pour the test portion of powder into one of the funnels with the 2,5 mm orifice and, from that, directly into the cylindrical cup, until this is completely filled and the powder flows over. Level the powder in one operation with a non-magnetic straight-edge without compressing it, and take care not to jar or vibrate the cup.

**8.2** If the powder does not flow through this funnel, use the funnel with the 5 mm orifice. If the powder still does not flow, it is acceptable to initiate flow by poking once with a 1 mm wire from the top of the funnel. The wire shall not enter the cup.

**8.3** After levelling the powder, tap the cup to settle the powder, in order to avoid spilling it during transport. Make sure that there are no adhering particles on the exterior of the cup.

**8.4** Determine the mass of the powder to the nearest 0,01 g.

8.5 Carry out the determinations on three test portions.

## 9 Expression of results

The apparent density is given by the formula

$$\rho_{ac} = \frac{m}{V} = \frac{m}{25}$$

Report the arithmetical mean of the three determinations to the nearest 0,01 g/cm<sup>3</sup>, and also the highest and lowest results if the scatter between results exceeds 1 % of the mean.

## 10 Precision

### 10.1 Repeatability

Duplicated tests with the same equipment, by the same operator, on a homogenized batch of powder, should be considered suspect if they differ by more than 0,03 g/cm<sup>3</sup> at a 95 % confidence level.

### 10.2 Reproducibility

Results from two different laboratories, on the same homogenized batch of powder, should be considered suspect if they differ by more than 0,05 g/cm<sup>3</sup> at a 95 % confidence level.

## 11 Test report

The test report shall include the following information:

- a) a reference to this document (i.e. ISO 3923-1:2018);
- b) all details necessary for the identification of the test sample;
- c) the drying procedure, if the powder has been dried;
- d) the nominal diameter of the orifice, cone angle of the funnel and the use of a wire, if applied;
- e) the result obtained;
- f) all operations not specified in this document, or regarded as optional;
- g) details of any occurrence which may have affected the result.



## Annex A (normative)

### Carney funnel

The dimensions of a Carney funnel according to ASTM B417[2] are shown in [Figure A.1](#).

Dimensions in millimetres

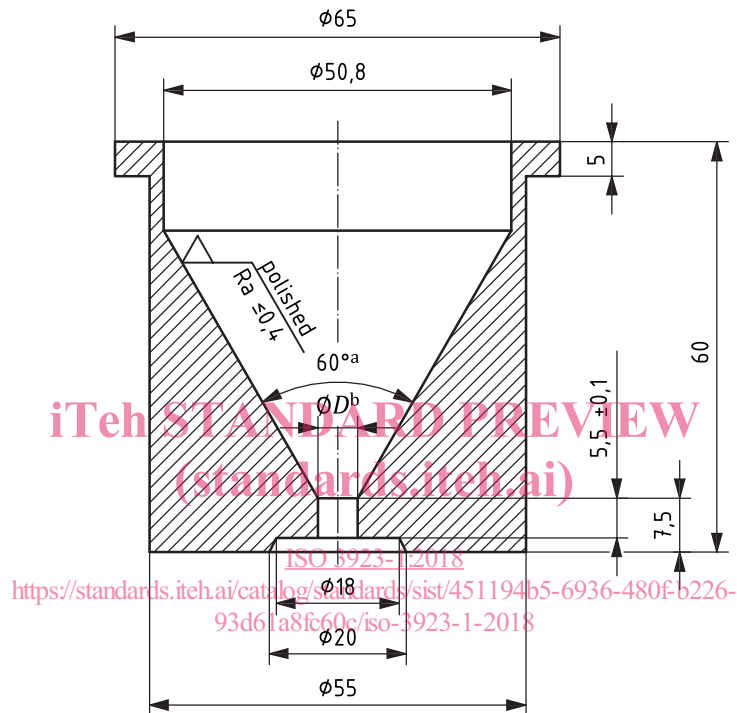

a This value is mandatory.

b  $D = 5_0^{+0,2}$

Figure A.1 — Carney funnel with orifice diameter of 5 mm