

---

---

## Hardmetals — Compression test

*Métaux durs — Essai de compression*

**iTeh STANDARD PREVIEW**  
**(standards.iteh.ai)**

[ISO 4506:2018](https://standards.iteh.ai/catalog/standards/sist/ba5acf3a-c4bf-4abc-8ee4-6445ce823d28/iso-4506-2018)

<https://standards.iteh.ai/catalog/standards/sist/ba5acf3a-c4bf-4abc-8ee4-6445ce823d28/iso-4506-2018>



**iTeh STANDARD PREVIEW**  
**(standards.iteh.ai)**

ISO 4506:2018

<https://standards.iteh.ai/catalog/standards/sist/ba5acf3a-c4bf-4abc-8ee4-6445ce823d28/iso-4506-2018>



**COPYRIGHT PROTECTED DOCUMENT**

© ISO 2018

All rights reserved. Unless otherwise specified, or required in the context of its implementation, no part of this publication may be reproduced or utilized otherwise in any form or by any means, electronic or mechanical, including photocopying, or posting on the internet or an intranet, without prior written permission. Permission can be requested from either ISO at the address below or ISO's member body in the country of the requester.

ISO copyright office  
CP 401 • Ch. de Blandonnet 8  
CH-1214 Vernier, Geneva  
Phone: +41 22 749 01 11  
Fax: +41 22 749 09 47  
Email: [copyright@iso.org](mailto:copyright@iso.org)  
Website: [www.iso.org](http://www.iso.org)

Published in Switzerland

# Contents

Page

Foreword .....	iv
<b>1 Scope .....</b>	<b>1</b>
<b>2 Normative references .....</b>	<b>1</b>
<b>3 Terms and definitions .....</b>	<b>1</b>
<b>4 Principle .....</b>	<b>1</b>
<b>5 Symbols and designations .....</b>	<b>1</b>
<b>6 Apparatus .....</b>	<b>1</b>
<b>7 Test piece .....</b>	<b>2</b>
<b>8 Procedure .....</b>	<b>2</b>
8.1 Rate of stress increase .....	2
8.2 Determination of proof stress .....	2
8.3 Determination of ultimate compressive strength .....	3
<b>9 Expression of results .....</b>	<b>3</b>
<b>10 Test report .....</b>	<b>3</b>
<b>Bibliography .....</b>	<b>6</b>

## iTeh STANDARD PREVIEW (standards.iteh.ai)

[ISO 4506:2018](https://standards.iteh.ai/catalog/standards/sist/ba5acf3a-c4bf-4abc-8ee4-6445ce823d28/iso-4506-2018)

<https://standards.iteh.ai/catalog/standards/sist/ba5acf3a-c4bf-4abc-8ee4-6445ce823d28/iso-4506-2018>

## Foreword

ISO (the International Organization for Standardization) is a worldwide federation of national standards bodies (ISO member bodies). The work of preparing International Standards is normally carried out through ISO technical committees. Each member body interested in a subject for which a technical committee has been established has the right to be represented on that committee. International organizations, governmental and non-governmental, in liaison with ISO, also take part in the work. ISO collaborates closely with the International Electrotechnical Commission (IEC) on all matters of electrotechnical standardization.

The procedures used to develop this document and those intended for its further maintenance are described in the ISO/IEC Directives, Part 1. In particular the different approval criteria needed for the different types of ISO documents should be noted. This document was drafted in accordance with the editorial rules of the ISO/IEC Directives, Part 2 (see [www.iso.org/directives](http://www.iso.org/directives)).

Attention is drawn to the possibility that some of the elements of this document may be the subject of patent rights. ISO shall not be held responsible for identifying any or all such patent rights. Details of any patent rights identified during the development of the document will be in the Introduction and/or on the ISO list of patent declarations received (see [www.iso.org/patents](http://www.iso.org/patents)).

Any trade name used in this document is information given for the convenience of users and does not constitute an endorsement.

For an explanation on the voluntary nature of standards, the meaning of ISO specific terms and expressions related to conformity assessment, as well as information about ISO's adherence to the World Trade Organization (WTO) principles in the Technical Barriers to Trade (TBT) see the following URL: [www.iso.org/iso/foreword.html](http://www.iso.org/iso/foreword.html). (standards.iteh.ai)

This document was prepared by Technical Committee ISO/TC 119, *Powder metallurgy*, Subcommittee SC 4, *Sampling and testing methods for hardmetals*. ISO 4506:2018

<https://standards.iteh.ai/catalog/standards/sist/ba5acf3a-c4bf-4abc-8ee4-444f1c23d166>

This second edition cancels and replaces the first edition (ISO 4506:1979), which has been technically revised with the following main changes:

- [Clause 2](#) and [Clause 3](#) added;
- [Clause 4](#): “hardmetal” changed to “cemented carbide or pcd (polycrystalline diamond) coated cemented carbide bearing blocks at room temperature”;
- [Clause 5](#): [Table 1](#) revised;
- [Clause 6](#): “hardmetal” changed to “cemented carbide”, hardness changed to “1 800 HV”;
- [8.2.2.2](#): NOTE changed to body text and “or using a laser extensometer” added to end of first sentence;
- [Clause 9](#): “at least five determinations” changed to “at least eight determinations”;
- [Clause 10](#), [Figure 1](#): “pcd” added;
- [Clause 10](#), [Figure 2](#): diameter “16 ± 0,3” changed to “12 ± 0,3”.

# Hardmetals — Compression test

## 1 Scope

This document specifies a method of determining the ultimate strength and proof stress of cemented carbide under uniaxial compressive loads.

## 2 Normative references

There are no normative references in this document.

## 3 Terms and definitions

No terms and definitions are listed in this document.

ISO and IEC maintain terminological databases for use in standardization at the following addresses:

- ISO Online browsing platform: available at <https://www.iso.org/obp>
- IEC Electropedia: available at <http://www.electropedia.org/>

## 4 Principle

Axial loading of a test piece, placed between two cemented carbide or pcd (polycrystalline diamond) coated cemented carbide bearing blocks at room temperature, until the intended deformation occurs or until the test piece fractures.

## 5 Symbols and designations

Table 1 shows symbols and designations.

**Table 1 — Symbols and designations**

Symbol	Designation	Unit
$S_0$	Minimum original cross-sectional area	mm <sup>2</sup>
$F_c$	(With index) Load at proof stress, for example:	
$F_{c0,2}$	Load at 0,2 % proof stress	N
$F_{cu}$	Ultimate load, i.e. load at instant of fracture	N
$R$	Stress	N/mm <sup>2</sup>
$\epsilon_c$	Strain	%
$E$	Young's modulus	N/mm <sup>2</sup>
$R_c$	(With index) Proof stress, for example:	
$\sigma_{0,2}$	0,2 % proof stress	N/mm <sup>2</sup>
UCS	Ultimate compressive strength	N/mm <sup>2</sup>

## 6 Apparatus

The test machine shall be designed and constructed so that loads can be applied at a uniform rate and so that, within the measuring range in question, the maximum loading error will be  $\pm 1$  %.

The test piece shall be affixed between two well-centred and rigidly secured cemented carbide anvils with a hardness not less than 1 800 HV. These contact surfaces shall be perpendicular to the loading axis and parallel to each other within 0,5  $\mu\text{m}/\text{mm}$ . An example of a suitable anvil is given in [Figure 1](#).

## 7 Test piece

**7.1** The dimensions of the test piece shall conform to [Figure 2](#). The end faces and the cylindrical surfaces of the enlarged ends shall be ground. Other surfaces should not be ground. (Grinding or polishing may affect the result of the test.)<sup>1)</sup>

**7.2** The minimum diameter of the test piece shall be measured with an accuracy of  $\pm 0,02$  mm.

## 8 Procedure

### 8.1 Rate of stress increase

The rate at which the load is applied shall be as uniform as possible, and any changes in this rate shall be made gradually and without shock. The rate shall not exceed 8 000 N/s, corresponding approximately to 100 N/( $\text{mm}^2 \times \text{s}$ ).

### 8.2 Determination of proof stress

**8.2.1** The proof stress, for example the 0,2 % proof stress, is determined according to [Figure 3](#). This method is based on the fact, valid for almost all metals, that if a load is removed after the elastic limit, D, has been exceeded, the load-compression curve will follow a linear path that is roughly parallel to the loading curve below the elastic limit.

iTeh STANDARD PREVIEW  
(standards.iteh.ai)  
ISO 4506:2018  
<https://standards.iteh.ai/catalog/standards/sist/ba5acf3a-c4bf-4abc-8ee4-415c82016c18/iso-4506-2018>

**8.2.2** Determination of proof stress using the graphic intersection method is carried out as follows.

**8.2.2.1** Apply a pre-load not greater than that required to keep the test piece positioned properly in the machine.

**8.2.2.2** Determine the stress-strain curve.

Because of the shortness of the test zone and the hardness of the material, practical difficulties are involved in measuring changes in length using displacement gauges of the clamp-on type (extensometers) or using a laser extensometer. It is recommended that changes in length be measured using a resistive strain gauge. Two or three gauges should be applied symmetrically at the centre of the test zone. The active length of the gauges should not exceed 8 mm. The results obtained represent an average of the change in length of the test zone.

**8.2.2.3** On the graph thus plotted ([Figure 3](#)), make OB equal to the specified residual strain (offset), and draw a line BA from B parallel to OC. Ordinate  $F_C$  of intersection point Q has the value  $F_{Cq}$  and represents the load that corresponds to the proof stress.

It is sometimes difficult to ascertain the direction of line OC from a graph; in such cases, this line can be drawn on the basis of an agreed value of the Young's modulus.

---

1) Cylindrical test pieces such as those specified in ASTM E 9 may be used to obtain results with potentially less accuracy.

8.2.3 The proof stress  $\sigma_{0,2}$ , in newtons per square millimetre, is given by [Formula \(1\)](#):

$$\sigma_{0,2} = \frac{F_{cq}}{S_0} \quad (1)$$

### 8.3 Determination of ultimate compressive strength

8.3.1 Load the test piece to fracture.

8.3.2 The ultimate compressive strength (UCS), in newtons per square millimetre, is given by [Formula \(2\)](#):

$$\text{UCS} = \frac{F_{cu}}{S_0} \quad (2)$$

## 9 Expression of results

Report the arithmetical mean of at least eight determinations, rounded to the nearest 10 N/mm<sup>2</sup>.

## 10 Test report **iTeh STANDARD PREVIEW**

The test report shall include the following information:

- reference to this document, i.e. ISO 4506;
- all details necessary for identification of the test piece;
- the result obtained;
- all operations not specified by this document, or regarded as optional;
- details of any occurrence which may have affected the result.

Dimensions in millimetres

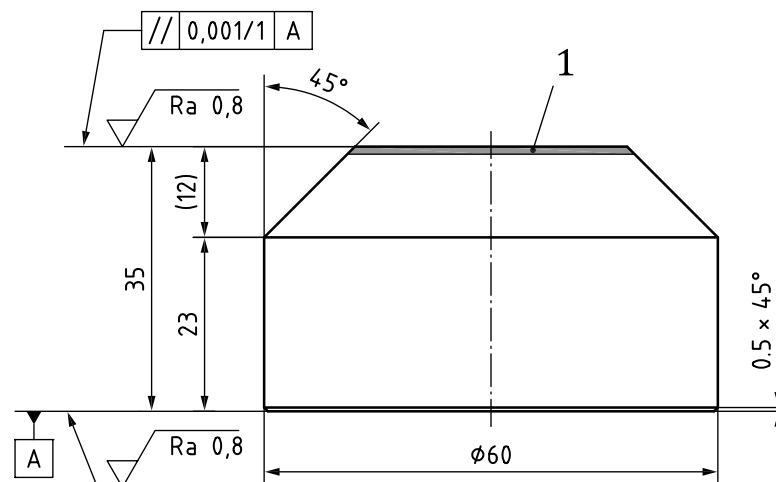

#### Key

- 1 pcd (polycrystalline diamond)

**Figure 1 — Suitable cemented carbide anvil**

Dimensions in millimetres

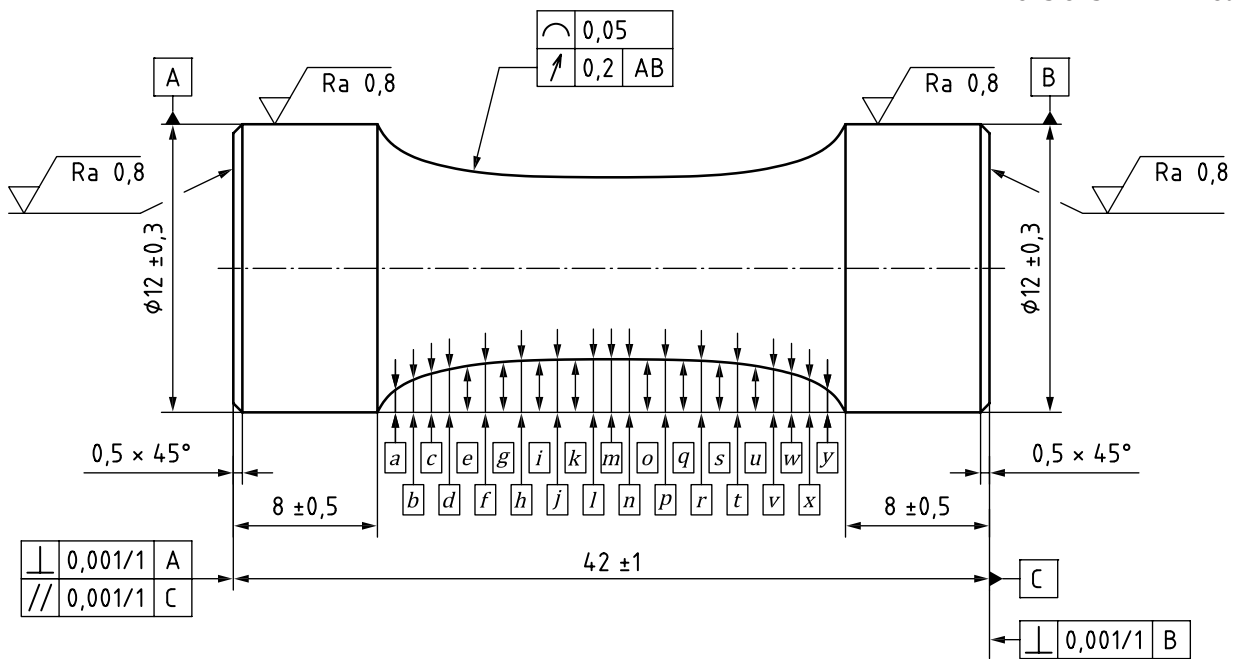

<i>a</i>	<i>b</i>	<i>c</i>	<i>d</i>	<i>e</i>	<i>f</i>	<i>g</i>	<i>h</i>	<i>i</i>	<i>j</i>	<i>k</i>	<i>l</i>	
1,21	1,90	2,29	2,54	2,69	2,79	2,86	2,91	2,94	2,96	2,98	2,99	
<i>m</i>	<i>n</i>	<i>o</i>	<i>p</i>	<i>q</i>	<i>r</i>	<i>s</i>	<i>t</i>	<i>u</i>	<i>v</i>	<i>w</i>	<i>x</i>	<i>y</i>
3,00	2,99	2,98	2,96	2,94	2,91	2,86	2,79	2,69	2,54	2,29	1,90	1,21

NOTE The 25 coordinates *a* to *y* are at 1 mm intervals.  
<https://standards.iteh.ai/catalog/standards/sist/ba5acf3a-c4bf-4abc-8ee4-6445ce823d28/iso-4506-2018>

Figure 2 — Test piece



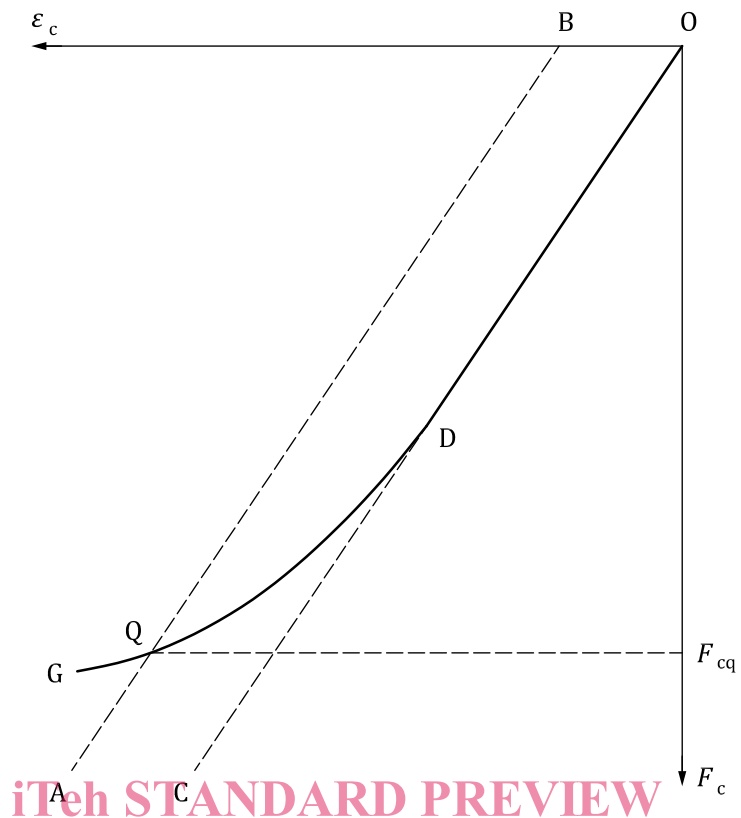

**iTeh STANDARD PREVIEW**

**Figure 3 — Load-compression curve**

ISO 4506:2018

<https://standards.iteh.ai/catalog/standards/sist/ba5acf3a-c4bf-4abc-8ee4-6445ce823d28/iso-4506-2018>