International Standard



2137

INTERNATIONAL ORGANIZATION FOR STANDARDIZATION • МЕЖДУНАРОДНАЯ ОРГАНИЗАЦИЯ ПО СТАНДАРТИЗАЦИИ • ORGANISATION INTERNATIONALE DE NORMALISATION

Petroleum products — Lubricating grease and petrolatum — Determination of cone penetration

Produits pétroliers — Graisse lubrifiante et pétrolatum — Détermination de la pénétrabilité au cône

Second edition — 1985-11-01

iteh STANDARD PREVIEW
(standards.iteh.ai)

[ISO 2137:1985](https://standards.iteh.ai/catalog/standards/sist/cec51b0d-e5d4-4a70-b91d-fba26f6f3b24/iso-2137-1985)

<https://standards.iteh.ai/catalog/standards/sist/cec51b0d-e5d4-4a70-b91d-fba26f6f3b24/iso-2137-1985>

UDC 665.765 : 620.1 : 539.57

Ref. No. ISO 2137-1985 (E)

Descriptors : petroleum products, lubricants, greases, petrolatum, rheological properties, tests, penetration tests.

Price based on 15 pages

Foreword

ISO (the International Organization for Standardization) is a worldwide federation of national standards bodies (ISO member bodies). The work of preparing International Standards is normally carried out through ISO technical committees. Each member body interested in a subject for which a technical committee has been established has the right to be represented on that committee. International organizations, governmental and non-governmental, in liaison with ISO, also take part in the work.

Draft International Standards adopted by the technical committees are circulated to the member bodies for approval before their acceptance as International Standards by the ISO Council. They are approved in accordance with ISO procedures requiring at least 75 % approval by the member bodies voting.

International Standard ISO 2137 was prepared by Technical Committee ISO/TC 28, *Petroleum products and lubricants*.

International Standard ISO 2137 was first published in 1972. This second edition cancels and replaces the first edition, of which it constitutes a technical revision.

Users should note that all International Standards undergo revision from time to time and that any reference made herein to any other International Standard implies its latest edition, unless otherwise stated.

Petroleum products — Lubricating grease and petrolatum — Determination of cone penetration

0 Introduction

This International Standard describes several methods for the empirical estimation of the consistency of lubricating greases and petrolatum by measuring the penetration of a standard cone.

1 Scope and field of application

1.1 Section one of this International Standard specifies four procedures for determination of the consistency of lubricating greases by measurement of the penetration of a standard cone. These procedures cover the measurement of unworked, worked, prolonged worked, and block penetrations. Penetrations up to 620 units may be measured.

1.2 Section two of this International Standard specifies methods for the determination of the consistency of lubricating greases, when only small samples are available, by the use of cones a half or quarter scale of that used in Section one.

The methods are applicable to greases having penetrations of 175 to 385 units with the standard cone and are intended for use only if the size of the test sample prevents the use of Section one.

They are not intended to replace the full-scale penetration as described in Section one, although a conversion to full-scale penetrations is given in 13.2.

NOTES

1 Unworked penetrations do not generally represent the consistency of greases in use as effectively as do worked penetrations. The latter are usually preferred for inspecting lubricating greases.

2 Penetration of block greases can be obtained on those products which are sufficiently hard to hold their shape. These greases generally have penetrations below 85 units.

1.3 Section three of this International Standard specifies a method for the determination of the consistency of petrolatums by measurement of the penetration of a standard cone, having penetrations up to 300 units.

This method may also be used to estimate the consistency of slack waxes.

1.4 Section four of this International Standard describes the calculation of results, precision data and the test report.

2 Definitions

2.1 cone penetration: The distance that a standard cone penetrates into a test portion under standardized conditions of load, time, and temperature.

NOTE — It is expressed in units of 0,1 mm.

2.2 working: The subjection of a lubricating grease to the shearing action of a grease worker.

2.3 unworked penetration: The cone penetration of a test portion which has received only minimum disturbance in transfer from the sample container to the cup of the grease worker.

2.4 worked penetration: The cone penetration of a test portion after it has been subjected to a defined number of strokes in a grease worker.

2.5 prolonged worked penetration: The cone penetration of a test portion which has been worked more than the defined number of strokes in 2.4.

2.6 block penetration: The cone penetration determined on a test portion which is sufficiently hard to hold its shape without container.

3 Principles

The cone penetration of lubricating grease is determined at 25 °C by releasing the cone assembly from the penetrometer and allowing the cone to drop for 5 s, and measuring the extent of the penetration.

Unworked penetrations are determined on test portions transferred with a minimum of disturbance to a container suitable for test purposes.

Worked penetrations are determined immediately after working the test portion for 60 double strokes in a standard grease worker.

Prolonged worked penetrations are determined on test portions worked more than 60 double strokes.

Block penetrations are determined on a freshly prepared face of a cube cut from a block of grease with a standard cutter.

The cone penetration of petrolatum is determined by first melting and cooling a test sample under prescribed conditions, and then measuring the penetration as for lubricating grease.

4 Apparatus

4.1 Penetrometer, similar to that shown in figure 1, designed to measure, in tenths of a millimetre, the penetration of a cone in a material. The cone assembly or the table of the penetrometer shall be adjustable to enable accurate placement of the tip of the cone on the level surface of the material while maintaining a "zero" reading on the indicator. The cone shall fall, when released, without appreciable friction for at least 62 mm. The tip of the cone shall not hit the bottom of the sample container. The instrument shall be provided with leveling screws and a spirit level to maintain the cone shaft in a vertical position.

4.2 Cones

4.2.1 Standard cone, consisting of a conical body of magnesium or other suitable material with a detachable, hardened steel tip. Dimensions and tolerances shall be as shown in figure 2. The total mass of the cone shall be $102,5 \pm 0,05$ g and that of its movable attachments shall be $47,5 \pm 0,05$ g. The attachments consist of a rigid shaft having a stop at its upper end and a suitable means at its lower end for engaging the cone. The interior construction may be modified to achieve the specified mass, provided that the general contour and mass distribution are not altered. The outer surface shall be polished to a very smooth finish.

NOTE — For penetrations up to 400 units, the optional cone (figure 3) may be used.

4.2.2 One-half scale cone and shaft, of steel, stainless steel, or brass with a hardened steel tip of 45 to 50 Rockwell hardness C and constructed to conform to the dimensions and tolerances shown in figure 4. The shaft may be made of stainless steel. The total mass of the cone and its movable attachments shall be $37,5 \pm 0,050$ g. The mass of the cone shall be $22,5 \pm 0,025$ g. The mass of the movable attachments shall be $15 \pm 0,025$ g.

4.2.3 One-quarter scale cone and shaft, consisting of a conical body of plastics or other low density material with a

hardened steel tip of 45 to 50 Rockwell hardness C, and constructed to conform to the dimensions and tolerances shown in figure 5. The shaft may be constructed of magnesium alloy. The total mass of the cone and its movable attachments shall be $9,38 \pm 0,025$ g. The total mass of the cone and its movable attachments may be adjusted by adding small shot to the cavity of the shaft.

4.3 Grease workers

4.3.1 Grease worker, full-scale, conforming to the dimensions shown in figure 6. The sizes of non-dimensioned parts are not critical and may be varied according to individual requirements, other methods of fastening the cover and securing the worker may be used. The grease worker may be constructed for either manual or mechanical operation. The design shall be such that a rate of 60 ± 10 strokes per minute, with a length of 67 to 71 mm, can be maintained. A suitable thermometer, standardized at $25 \text{ }^\circ\text{C}$, shall be provided for insertion through the vent valve.

4.3.2 One-half scale grease worker, conforming to the dimensions given in figure 7. Other methods of fastening the cover and securing the worker may be used. The worker may be constructed for either manual or mechanical operation. The design shall be such that a rate of 60 ± 10 strokes per minute, with a maximum length of 35 mm, can be maintained.

4.3.3 One-quarter scale grease worker, conforming to the dimensions given in figure 8. Other methods of fastening the cover and securing the worker may be used. The worker may be constructed for either manual or mechanical operation. The design shall be such that a rate of 60 ± 10 strokes per minute, with a maximum length of 14 mm, can be maintained.

4.3.4 Overflow ring (optional), conforming in principle to the illustration in figure 6. This is a useful aid for returning displaced grease to the grease worker cup. The overflow ring shall be positioned at least 13 mm below the rim of the cup while making a penetration measurement. A rim 13 mm high is helpful.

4.4 Grease cutter, having a sharp, rigidly mounted, bevelled blade, essentially as shown in figure 9. It is necessary that the blade be straight and sharpened as shown.

4.5 Water bath, capable of being maintained at $25 \pm 0,5 \text{ }^\circ\text{C}$ and capable of holding the assembled grease worker. If the bath is to be used for samples for unworked penetrations, a means shall be provided for protecting the grease surface from water. A cover shall also be provided to maintain the air temperature above the sample at $25 \text{ }^\circ\text{C}$.

An air bath, maintained at $25 \pm 0,5 \text{ }^\circ\text{C}$, is required for determining block penetration; a tightly sealed container placed in the water bath will suffice.

NOTE — A constant temperature test room or an air bath may be used instead of a water bath.

4.6 Thermometer, calibrated at 25 °C, for the water or air bath.

4.7 Oven, capable of maintaining a temperature of 85 ± 2 °C, for melting the petrolatum samples.

4.8 Spatula, corrosion-resistant, square-ended, having a stiff blade 32 mm wide and at least 150 mm long; for tests with half- and quarter-scale cones the width should be approx. 13 mm.

4.9 Timer, graduated in 0,1 s.

4.10 Test portion containers for petrolatum, cylindrical, having a flat bottom 100 ± 5 mm in diameter and 65 mm or more in depth, constructed of metal at least 1,6 mm thick and, if necessary, each provided with a well-fitting watertight cover (see the note 1 to 12.1.3).

NOTE — Containers of the "ointment box" type having somewhat flexible sides should not be used, for these permit slight working of the petrolatum, due to flexing of the sides in handling.

5 Sampling

Take a representative sample of the product to be tested.

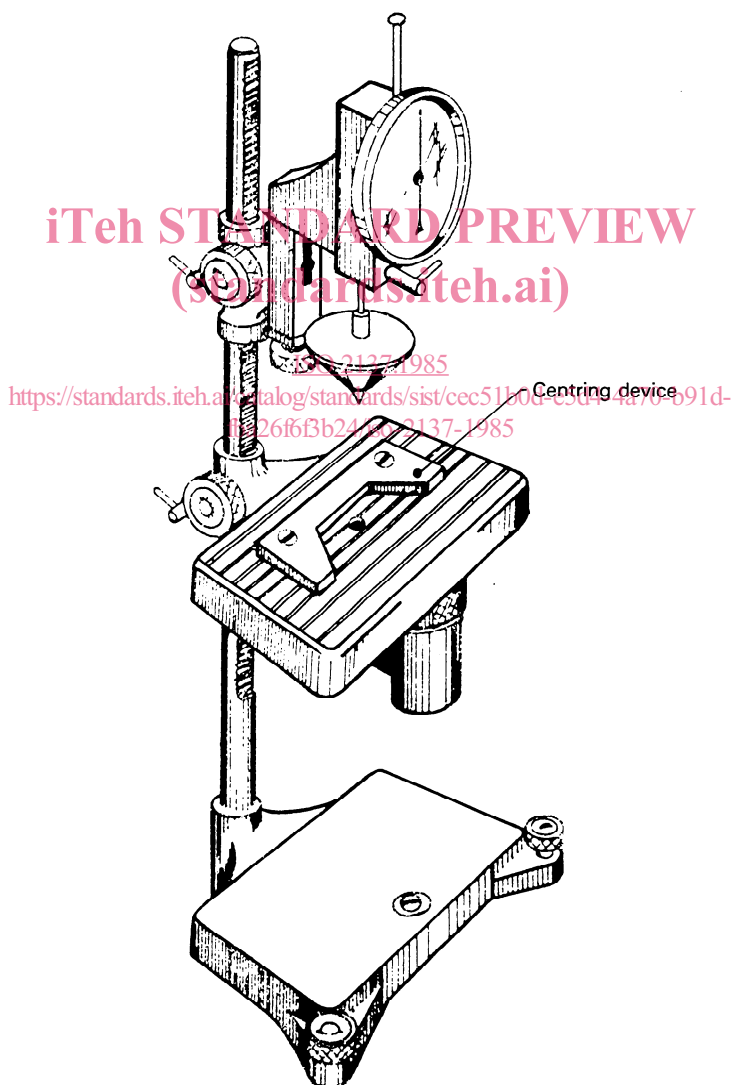

NOTE — This is a combined figure; generally either the cone assembly or the table can be moved vertically.

Figure 1 — Penetrometer

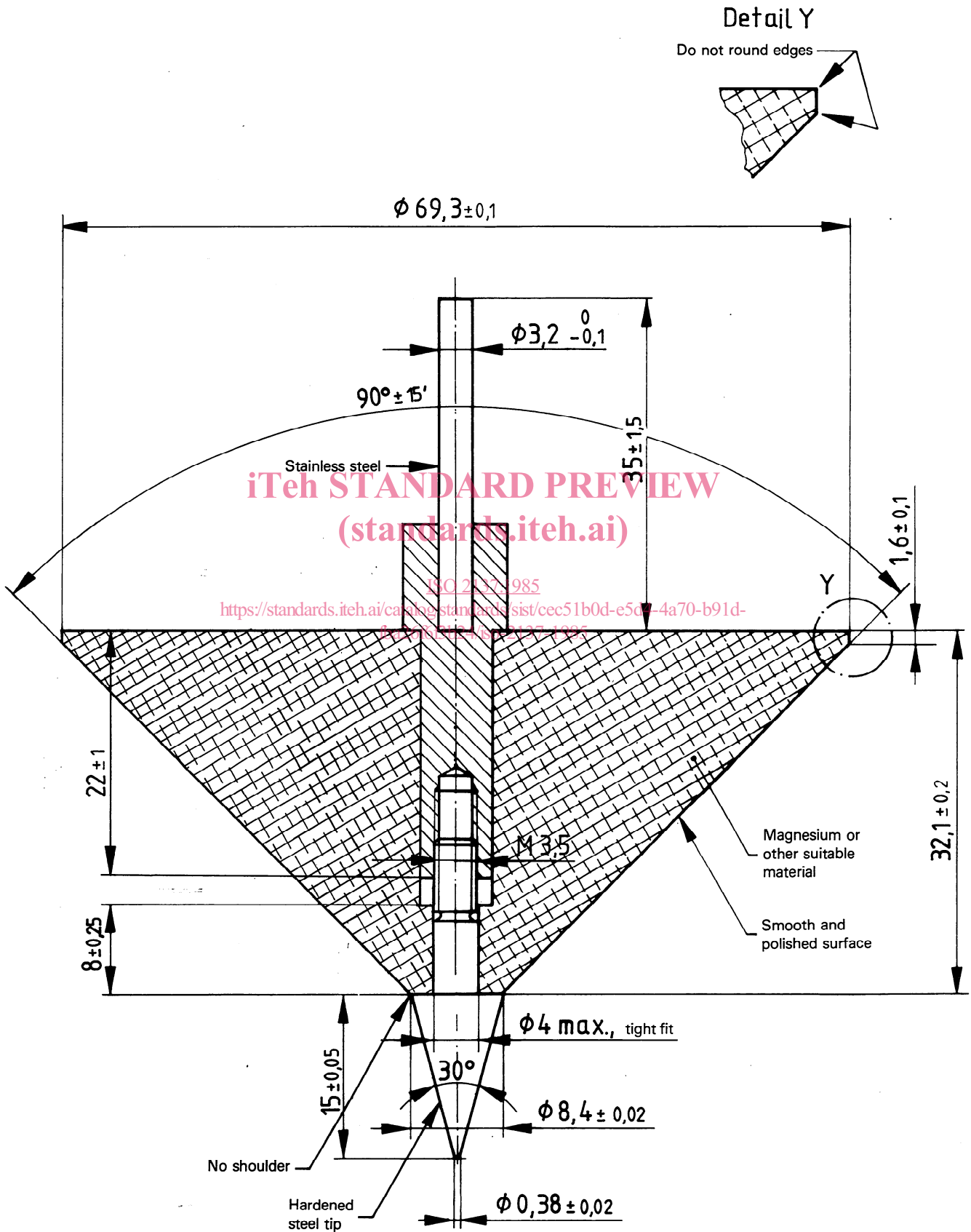
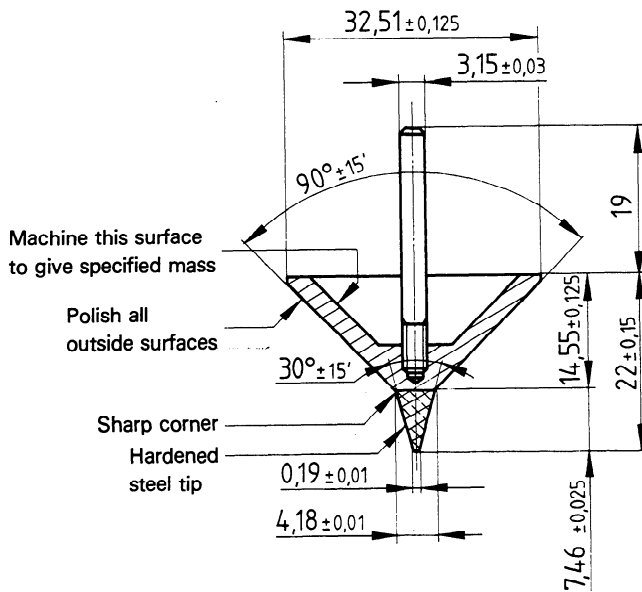

Figure 2 — Penetrometer cone, standard

Dimensions in millimetres



Mass of cone: $22,5 \pm 0,025$ g
 Mass of movable attachments: $15 \pm 0,025$ g
 Total mass of cone and its movable attachments: $37,5 \pm 0,050$ g

Figure 4 — One-half scale cone
 iTeh STANDARD PREVIEW
 (standards.iteh.ai)

ISO 2137:1985

<https://standards.iteh.ai/catalog/standards/sist/cec51b0d-e5d4-4a70-b91d-fba26f63b24/iso-2137-1985>
 Dimensions in millimetres

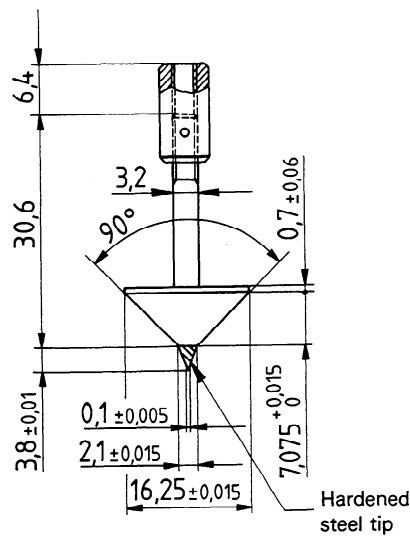

Total mass of cone and movable attachments:
 $9,38 \pm 0,025$ g

Figure 5 — One-quarter scale cone

Dimensions in millimetres

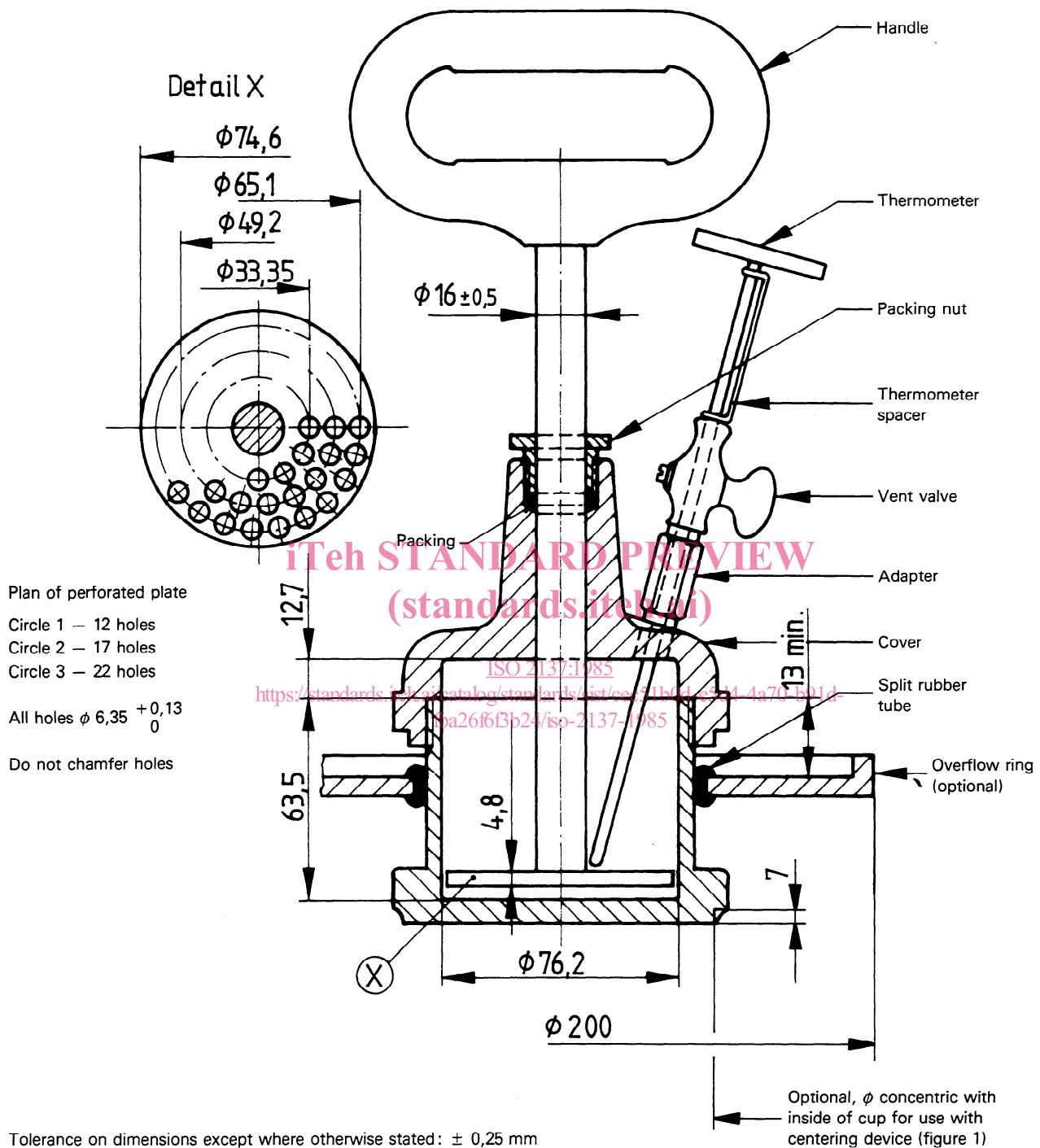
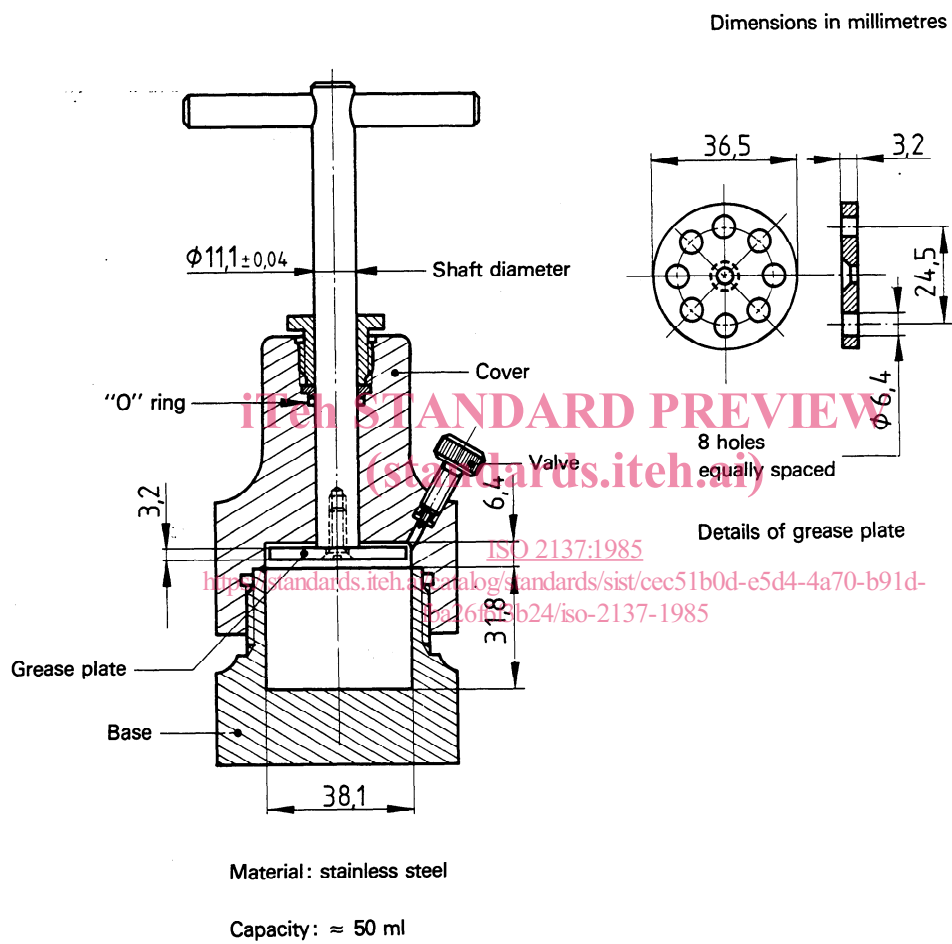
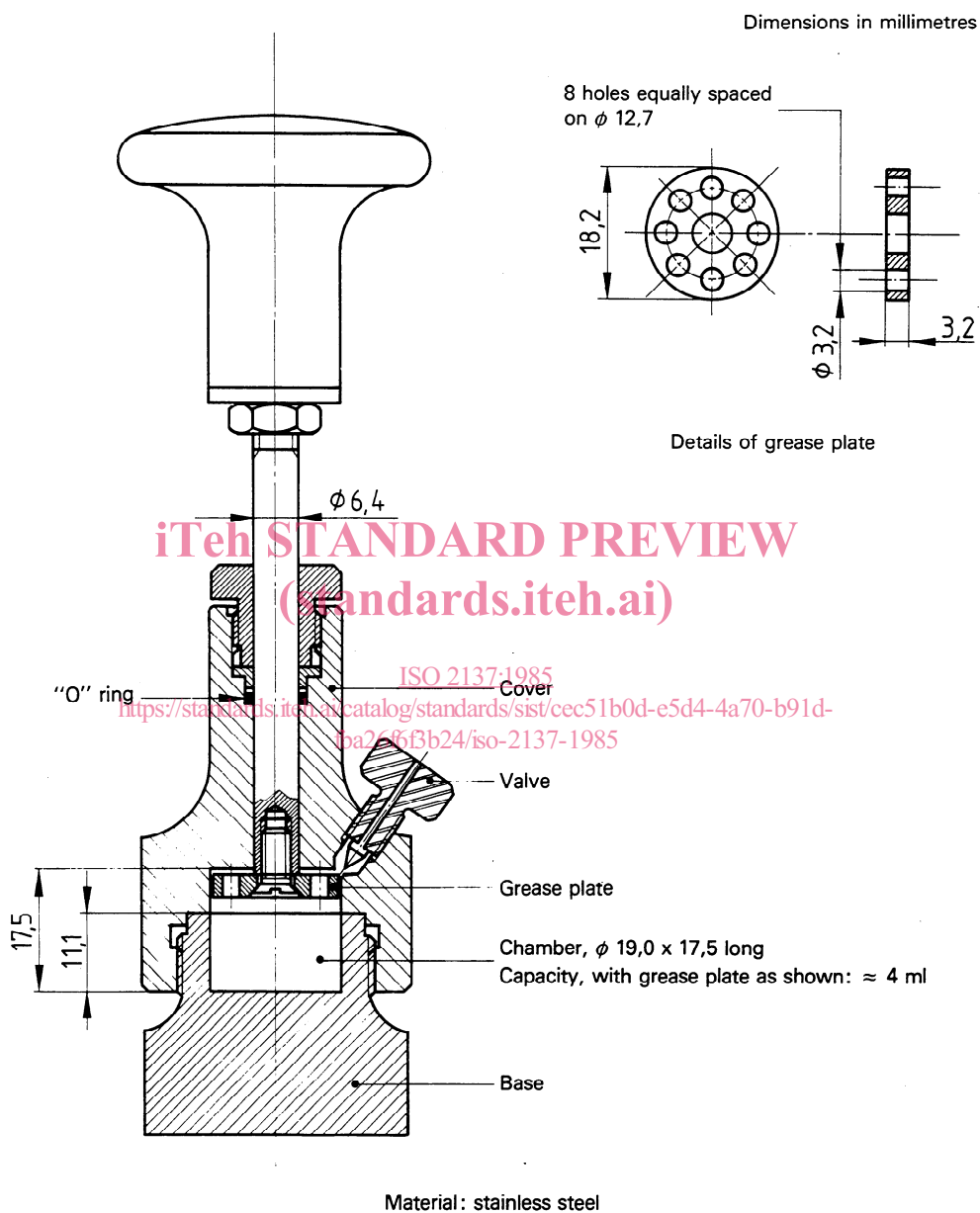

Figure 6 — Grease worker, full-scale



Tolerance on dimensions, except where otherwise stated : $\pm 0,25$ mm

Figure 7 – One-half scale grease worker



Tolerance on dimensions, except where otherwise stated : $\pm 0,25$ mm.

Figure 8 — One-quarter scale grease worker