**Assembly tools for screws and nuts —
Square drive sockets —**

**Part 1:
Hand-operated sockets**

*Outils de manœuvre pour vis et écrous — Douilles à carré conducteur
femelle —*

iTeh STANDARD PREVIEW
Partie 1: Douilles à main
(standards.iteh.ai)

ISO 2725-1:2017

<https://standards.iteh.ai/catalog/standards/sist/b4a56ff6-cb51-4250-a1a0-17b3d01adc44/iso-2725-1-2017>



iTeh STANDARD PREVIEW
(standards.iteh.ai)

ISO 2725-1:2017

<https://standards.iteh.ai/catalog/standards/sist/b4a56ff6-cb51-4250-a1a0-17b3d01adc44/iso-2725-1-2017>



COPYRIGHT PROTECTED DOCUMENT

© ISO 2017, Published in Switzerland

All rights reserved. Unless otherwise specified, no part of this publication may be reproduced or utilized otherwise in any form or by any means, electronic or mechanical, including photocopying, or posting on the internet or an intranet, without prior written permission. Permission can be requested from either ISO at the address below or ISO's member body in the country of the requester.

ISO copyright office
Ch. de Blandonnet 8 • CP 401
CH-1214 Vernier, Geneva, Switzerland
Tel. +41 22 749 01 11
Fax +41 22 749 09 47
copyright@iso.org
www.iso.org

Contents		Page
Foreword		iv
1 Scope		1
2 Normative references		1
3 Terms and definitions		1
4 Tolerances for width across flats		1
5 Dimensions		1
6 Designation		7
7 Marking		7
Bibliography		8

iTeh STANDARD PREVIEW
(standards.iteh.ai)

[ISO 2725-1:2017](https://standards.iteh.ai/catalog/standards/sist/b4a56ff6-cb51-4250-a1a0-17b3d01adc44/iso-2725-1-2017)

<https://standards.iteh.ai/catalog/standards/sist/b4a56ff6-cb51-4250-a1a0-17b3d01adc44/iso-2725-1-2017>

Foreword

ISO (the International Organization for Standardization) is a worldwide federation of national standards bodies (ISO member bodies). The work of preparing International Standards is normally carried out through ISO technical committees. Each member body interested in a subject for which a technical committee has been established has the right to be represented on that committee. International organizations, governmental and non-governmental, in liaison with ISO, also take part in the work. ISO collaborates closely with the International Electrotechnical Commission (IEC) on all matters of electrotechnical standardization.

The procedures used to develop this document and those intended for its further maintenance are described in the ISO/IEC Directives, Part 1. In particular the different approval criteria needed for the different types of ISO documents should be noted. This document was drafted in accordance with the editorial rules of the ISO/IEC Directives, Part 2 (see www.iso.org/directives).

Attention is drawn to the possibility that some of the elements of this document may be the subject of patent rights. ISO shall not be held responsible for identifying any or all such patent rights. Details of any patent rights identified during the development of the document will be in the Introduction and/or on the ISO list of patent declarations received (see www.iso.org/patents).

Any trade name used in this document is information given for the convenience of users and does not constitute an endorsement.

For an explanation on the voluntary nature of standards, the meaning of ISO specific terms and expressions related to conformity assessment, as well as information about ISO's adherence to the World Trade Organization (WTO) principles in the Technical Barriers to Trade (TBT) see the following URL: www.iso.org/iso/foreword.html. (standards.iteh.ai)

This document was prepared by Technical Committee ISO/TC 29, *Small tools*, Subcommittee SC 10, *Assembly tools for screws and nuts, pliers and nippers*.

This fourth edition cancels and replaces the third edition (ISO 2725-1:2015), which has been technically revised with the following changes:

- a) additional widths across flat sizes not covered by ISO 272 have been included, in order to better reflect the current market situation;
- b) [Clause 5](#) "Technical specifications" has been deleted, as these are given in ISO 1711-1.

A list of all parts in the ISO 2725 series can be found on the ISO website.

Assembly tools for screws and nuts — Square drive sockets —

Part 1: Hand-operated sockets

1 Scope

This document specifies dimensions, the designation, and the marking of hand-operated square drive sockets with operating end and having a hexagonal or double hexagonal form in accordance with ISO 1174-1.

NOTE Hand-operated square drive sockets covered by this document are the ones identified in ISO 1703 under reference numbers 2 1 02 01 0.

This document does not cover technical specifications for these products. Technical specifications are given in ISO 1711-1.

2 Normative references

The following documents are referred to in the text in such a way that some or all of their content constitutes requirements of this document. For dated references, only the edition cited applies. For undated references, the latest edition of the referenced document (including any amendments) applies.

ISO 691, *Assembly tools for screws and nuts — Wrench and socket openings — Tolerances for general use*

ISO 1174-1, *Assembly tools for screws and nuts — Driving squares — Part 1: Driving squares for hand socket tools*

3 Terms and definitions

No terms and definitions are listed in this document.

ISO and IEC maintain terminological databases for use in standardization at the following addresses:

- ISO Online browsing platform: available at <http://www.iso.org/obp>
- IEC Electropedia: available at <http://www.electropedia.org/>

4 Tolerances for width across flats

Tolerances for width across flats, s , shall be in conformity with the tolerances for socket openings given in ISO 691. Manufacturers are free to choose the series of deviations.

5 Dimensions

Table 1 to Table 5 gives the dimensions, in millimetres, of sockets shown in Figure 1 to Figure 3 for driving squares of 6,3 to 25, which shall be in accordance with ISO 1174-1.

The figures in this document are given only as examples. They are not intended to influence the manufacturer's design.

NOTE Width across flats, s , are partly taken from ISO 272.

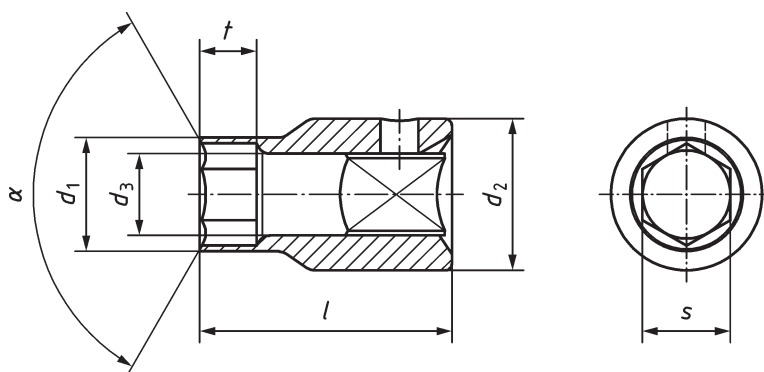

Key

α $115^\circ \leq \alpha \leq 150^\circ$

Figure 1 — Sockets with $d_1 < d_2$

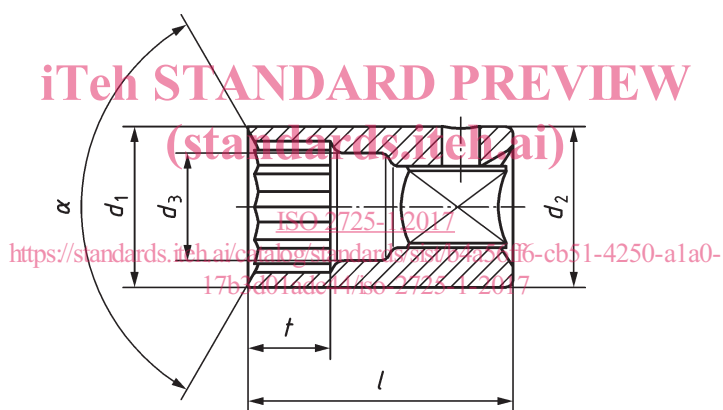

Key

α $115^\circ \leq \alpha \leq 150^\circ$

Figure 2 — Sockets with $d_1 = d_2$

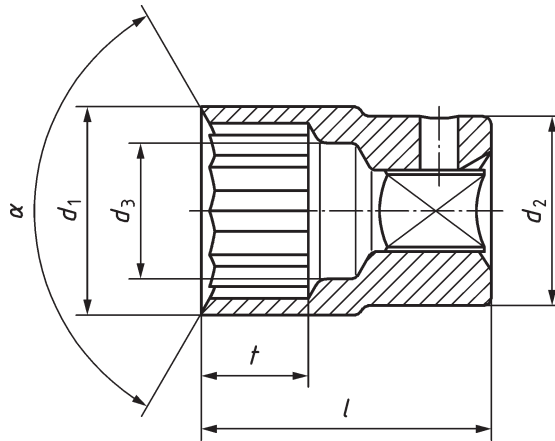
**Key**
 $\alpha \quad 115^\circ \leq \alpha \leq 150^\circ$
Figure 3 — Sockets with $d_1 > d_2$ **Table 1 — Square drive of 6,3**

s	D_{\max}^c mm	d_1^a min. mm	d_1 max. mm	d_2 max. mm	d_3^b min. Bolt clearance hole mm	l	
						max. Type A (normal) mm	min. Type B (long) mm
3,2	1,6	1,4	5,9	12,5	1,7	26	45
4	2	1,7	6,9	12,5	2,1	26	45
5	2,5	2,1	8,2	12,5	2,6	26	45
5,5	3	2,5	8,8	12,5	3,2	26	45
6 ^d	3,5 ^f	2,9	9,4	12,5	3,7	26	45
7	5	3,3	11	12,5	5,3	26	45
8	6	4,8	12,2	12,5	6,3	26	45
9 ^d	6 ^e	5,1	13,5	13,5	6,3	26	45
10	8	5,3	14,7	14,7	8,4	26	45
11	8 ^e	5,8	16	16	8,4	26	45
12 ^d	8	6,4	17,2	17,2	8,4	26	45
13	10	6,9	18,5	18,5	10,5	26	45
14 ^d	10	7,4	19,7	19,7	10,5	26	45
15 ^d	12	8,0	21,5	21,5	12,6	26	45
16	12 ^e	8,5	22	22	12,6	26	45
17 ^d	12	9,7	22,5	22,5	12,6	26	45

NOTE t_{\min} is interpolated for sizes not covered by ISO 4032 and ISO 4014.

^a $t_{\min} = m_{\max} + 0,1$; where m_{\max} is the maximum height of the nut, according to ISO 4032.

^b $d_{3\min} = D_{\max} \times 1,05$.

^c The maximum thread diameter, D_{\max} , is the largest nominal thread diameter found in current International Standards like, for example, ISO 4014, ISO 4032 and ISO 272.

^d Nominal dimension not covered by ISO 272.

^e Value determined in order to avoid reduction in hole clearance size.

^f Value determined by market study.

Table 2 — Square drive of 10

s	D _{max} ^c mm	t ^a min. mm	d ₁ max. mm	d ₂ max. mm	d ₃ ^b min.	l	
					Bolt clearance hole mm	max. Type A (normal) mm	min. Type B (long) mm
6 ^d	3,5 ^f	2,9	10,1	20	3,7	32	44
7	5	3,3	11	20	5,3	32	44
8	6	4,8	12,2	20	6,3	32	44
9 ^d	6 ^e	5,1	13,5	20	6,3	32	44
10	8	5,3	14,7	20	8,4	32	44
11	8 ^e	5,8	16	20	8,4	32	44
12 ^d	8	6,4	17,2	20	8,4	32	44
13	10	6,9	18,5	20	10,5	32	44
14 ^d	10	7,4	19,7	24	10,5	32	45
15 ^d	12	8,0	21,0	24	12,6	32	45
16	12 ^e	8,5	22,2	24	12,6	35	50
17 ^d	12	9,7	23,5	24	12,6	35	54
18	14	10,9	24,7	24,7	14,7	35	54
19 ^d	14	11,9	26	26	14,7	35	60
20 ^d	14 ^e	12,4	27,8	27,8	14,7	35	60
21	16	12,9	28,5	28,8	16,8	38	60
22 ^d	16	13,9	29,7	29,7	16,8	38	60
23 ^d	16 ^e	14,4	31,3	31,3	16,8	38	60
24	16	14,9	32,5	32,5	16,8	38	65
25	18	14,9	33	33	18,3	38	65

NOTE t_{min} is interpolated for sizes not covered by ISO 4032 and ISO 4014.

a t_{min} = m_{max} + 0,1; where m_{max} is the maximum height of the nut, according to ISO 4032.

b d_{3min} = D_{max} × 1,05.

c The maximum thread diameter, D_{max}, is the largest nominal thread diameter found in current International Standards like, for example, ISO 4014, ISO 4032 and ISO 272.

d Nominal dimension not covered by ISO 272.

e Value determined in order to avoid reduction in hole clearance size.

f Value determined by market study.

Table 3 — Square drive of 12,5

s	D_{\max}^c mm	t^a min. mm	d_1 max. mm	d_2 max. mm	d_3^b min. mm	l	
						max. Type A (normal) mm	min. Type B (long) mm
8	6	4,8	14	24	6,3	40	75
9 ^d	6 ^e	5,1	14,1	24	5,8	40	75
10	8	5,3	15,5	24	8,4	40	75
11	8 ^e	5,8	16,7	24	8,4	40	75
12 ^d	8	6,4	18	24	8,4	40	75
13	10	6,9	19,2	24	10,5	40	75
14 ^d	10	7,4	20,5	24	10,5	40	75
15 ^d	12	8,0	21,7	24	12,6	40	75
16	12 ^e	8,5	23	25,5	12,6	40	75
17 ^d	12	9,7	24,2	25,5	12,6	40	75
18	14	10,9	25,5	25,5	14,7	42	75
19 ^d	14	11,9	26,7	26,7	14,7	42	75
20 ^d	14 ^e	12,4	28	28	14,7	42	75
21	16	12,9	29,2	29,2	16,8	44	75
22 ^d	16	13,9	30,5	30,5	16,8	44	75
23 ^d	16 ^e	14,4	31,3	31,3	16,8	46	75
24	16	14,9	33	33	16,8	46	75
25 ^d	18 ^e	14,9	33,4	33,4	18,3	46	75
27	20	15,9	36,7	36,7	21,0	48	75
30	20	18,1	40,5	40,5	21,0	50	75
32 ^d	24	18,8	43	43	25,2	50	75
34	24 ^e	19,5	46,5	46,5	25,2	52	75

NOTE t_{\min} is interpolated for sizes not covered by ISO 4032 and ISO 4014.

a $t_{\min} = m_{\max} + 0,1$; where m_{\max} is the maximum height of the nut, according to ISO 4032.

b $d_{3\min} = D_{\max} \times 1,05$.

c The maximum thread diameter, D_{\max} , is the largest nominal thread diameter found in current International Standards like, for example, ISO 4014, ISO 4032 and ISO 272.

d Nominal dimension not covered by ISO 272.

e Value determined in order to avoid reduction in hole clearance size.