**Assembly tools for screws and nuts —
Square drive sockets —**

Part 3:
**Machine-operated sockets (“non-
impact”)**

iTeh STANDARD PREVIEW
*Outils de manœuvre pour vis et écrous — Douilles à carré conducteur
femelle —
(standards.iteh.ai)
Partie 3: Douilles à machine (non-impact)*

ISO 2725-3:2017

<https://standards.iteh.ai/catalog/standards/sist/d4e85a78-277e-4f88-9a69-13ceea2f983c/iso-2725-3-2017>



iTeh STANDARD PREVIEW
(standards.iteh.ai)

ISO 2725-3:2017

<https://standards.iteh.ai/catalog/standards/sist/d4e85a78-277e-4f88-9a69-13ceea2f983c/iso-2725-3-2017>



COPYRIGHT PROTECTED DOCUMENT

© ISO 2017, Published in Switzerland

All rights reserved. Unless otherwise specified, no part of this publication may be reproduced or utilized otherwise in any form or by any means, electronic or mechanical, including photocopying, or posting on the internet or an intranet, without prior written permission. Permission can be requested from either ISO at the address below or ISO's member body in the country of the requester.

ISO copyright office
Ch. de Blandonnet 8 • CP 401
CH-1214 Vernier, Geneva, Switzerland
Tel. +41 22 749 01 11
Fax +41 22 749 09 47
copyright@iso.org
www.iso.org

Contents		Page
Foreword		iv
1 Scope		1
2 Normative references		1
3 Terms and definitions		1
4 Tolerances on width across flats		1
5 Dimensions		1
6 Designation		5
7 Marking		5
Bibliography		6

iTeh STANDARD PREVIEW
(standards.iteh.ai)

[ISO 2725-3:2017](https://standards.iteh.ai/catalog/standards/sist/d4e85a78-277e-4f88-9a69-13ceea2f983c/iso-2725-3-2017)

<https://standards.iteh.ai/catalog/standards/sist/d4e85a78-277e-4f88-9a69-13ceea2f983c/iso-2725-3-2017>

Foreword

ISO (the International Organization for Standardization) is a worldwide federation of national standards bodies (ISO member bodies). The work of preparing International Standards is normally carried out through ISO technical committees. Each member body interested in a subject for which a technical committee has been established has the right to be represented on that committee. International organizations, governmental and non-governmental, in liaison with ISO, also take part in the work. ISO collaborates closely with the International Electrotechnical Commission (IEC) on all matters of electrotechnical standardization.

The procedures used to develop this document and those intended for its further maintenance are described in the ISO/IEC Directives, Part 1. In particular the different approval criteria needed for the different types of ISO documents should be noted. This document was drafted in accordance with the editorial rules of the ISO/IEC Directives, Part 2 (see www.iso.org/directives).

Attention is drawn to the possibility that some of the elements of this document may be the subject of patent rights. ISO shall not be held responsible for identifying any or all such patent rights. Details of any patent rights identified during the development of the document will be in the Introduction and/or on the ISO list of patent declarations received (see www.iso.org/patents).

Any trade name used in this document is information given for the convenience of users and does not constitute an endorsement.

For an explanation on the voluntary nature of standards, the meaning of ISO specific terms and expressions related to conformity assessment, as well as information about ISO's adherence to the World Trade Organization (WTO) principles in the Technical Barriers to Trade (TBT) see the following URL: www.iso.org/iso/foreword.html. (standards.iteh.ai)

This document was prepared by Technical Committee ISO/TC 29, *Small tools*, Subcommittee SC 10, *Assembly tools for screws and nuts, pliers and nippers*.
ISO 2725-3:2017
<https://standards.iteh.ai/catalog/standards/sist/d4e85a78-277e-4f88-9a69-3a2227777777>

This third edition cancels and replaces the second edition (ISO 2725-3:2015), which has been technically revised to include additional widths across flat sizes not covered by ISO 272 in order to better reflect the current market situation.

A list of all parts in the ISO 2725 series can be found on the ISO website.

Assembly tools for screws and nuts — Square drive sockets —

Part 3: Machine-operated sockets (“non-impact”)

1 Scope

This document specifies dimensions, designation, and marking of machine-operated “non-impact” square drive sockets.

NOTE Machine-operated “non-impact” square drive sockets covered by this document are the ones identified in ISO 1703 under reference numbers 2 2 02 01 0.

2 Normative references

The following documents are referred to in the text in such a way that some or all of their content constitutes requirements of this document. For dated references, only the edition cited applies. For undated references, the latest edition of the referenced document (including any amendments).

ISO 691, *Assembly tools for screws and nuts — Wrench and socket openings — Tolerances for general use*

ISO 1174-2, *Assembly tools for screws and nuts — Driving squares — Part 2: Driving squares for power socket tools*

<https://standards.iteh.ai/catalog/standards/sist/d4e85a78-277e-4f88-9a69-13ceea2f983c/iso-2725-3-2017>

3 Terms and definitions

No terms and definitions are listed in this document.

ISO and IEC maintain terminological databases for use in standardization at the following addresses:

- ISO Online browsing platform: available at <http://www.iso.org/obp>
- IEC Electropedia: available at <http://www.electropedia.org/>

4 Tolerances on width across flats

Tolerances on width across flats, s , shall be in conformity with the tolerances for socket openings given in ISO 691. Manufacturers are free to choose the series of deviations.

5 Dimensions

See [Figure 1](#) to [Figure 3](#) and [Table 1](#) to [Table 5](#).

The figures in this document are given only as examples. They are not intended to influence the manufacturer’s design.

The driving squares shall conform with ISO 1174-2.

[Table 1](#) to [Table 3](#) give the dimensions of sockets for driving squares of 6,3, 10, and 12,5 (according to ISO 1174-2). [Table 4](#) gives the dimensions of the retaining pin. [Table 5](#) gives the dimensions of the retaining ring.

During use, the socket shall be maintained by a retaining ring and pin (type G) or by a plunger retainer (type J).

Retaining systems G and J can be used for all types of socket and are not dependent on the shape of the socket.

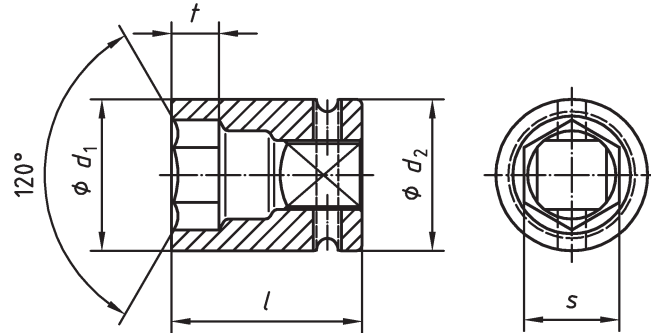

Figure 1 — Socket shown with type G square conforming to ISO 1174-2

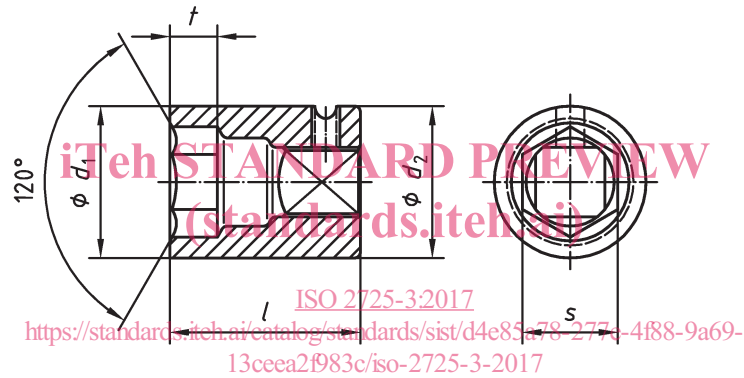

Figure 2 — Socket shown with type J square conforming to ISO 1174-2

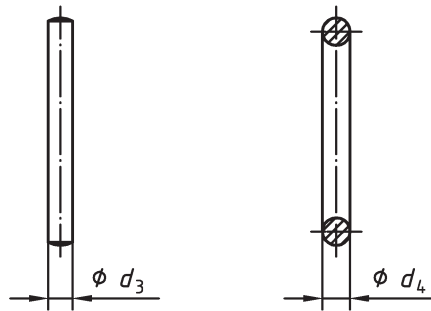

Figure 3 — Retaining pin and ring

Table 1 — Square drive of 6,3

<i>s</i>	D_{\max}^b mm	t^a min. mm	d_1 max. mm	d_2 max. mm	l max. mm
3,2	1,6	1,4	5,9	14	25
4	2	1,7	6,9		
5	2,5	2,1	8,2		
5,5	3	2,5	8,8		
6 ^c	3,5 ^e	2,9	9,4		
7	5	3,3	11		
8	6	4,8	12,2		
9 ^c	6 ^d	5,1	13,5	16	
10	8	5,3	14,7		
11	8 ^d	5,8	16	16,6	
12 ^c	8	6,4	17,2	17,8	
13	10	6,9	18,5	19,1	

a $t_{\min} = m_{\max} + 0,1$; where m_{\max} is the maximum height of the nut, according to ISO 4032.

b The maximum thread diameter, D_{\max} , is the largest nominal thread diameter found in current International Standards like, for example, ISO 4014, ISO 4032 and ISO 272.

c Nominal dimension not covered by ISO 272.

d Value determined in order to avoid reduction in hole clearance size.

e Value determined by market study.

Table 2 — Square drive of 10

<i>s</i>	D_{\max}^b mm	t^a min. mm	d_1 max. mm	d_2 max. mm	l max. mm
7	5	3,3	11	20	34
8	6	4,8	12,2		
9 ^c	6 ^d	5,1	13,5		
10	8	5,3	14,7		
11	8 ^d	5,8	16		
12 ^c	8	6,4	17,2	28	
13	10	6,9	18,5		
14 ^c	10	7,4	19,7		
15 ^c	12	8,0	21		
16	12 ^d	8,5	22,2		
17 ^c	12	9,7	23,5		
18	14	10,9	24,7		
19 ^c	14	11,9	26		
20 ^c	14 ^d	12,4	27,8		

a $t_{\min} = m_{\max} + 0,1$; where m_{\max} is the maximum height of the nut, according to ISO 4032.

b The maximum thread diameter, D_{\max} , is the largest nominal thread diameter found in current International Standards like, for example, ISO 4014, ISO 4032 and ISO 272.

c Nominal dimension not covered by ISO 272.

d Value determined in order to avoid reduction in hole clearance size.

Table 3 — Square drive of 12,5

<i>s</i>	<i>D</i> _{max} ^b mm	<i>t</i> ^a min. mm	<i>d</i> ₁ max. mm	<i>d</i> ₂ max. mm	<i>l</i> max. mm
10	8	5,3	15,5	28	40
11	8 ^d	5,8	16,7		
12 ^c	8	6,4	18,0		
13	10	6,9	19,2		
14 ^c	10	7,4	20,5	37	
15 ^c	12	8,0	21,7		
16	12 ^d	8,5	23		
17 ^c	12	9,7	24,2		
18	14	10,9	25,5		
19 ^c	14	11,9	26,7		
20 ^c	14 ^d	12,4	28		
21	16	12,9	29,2		
22 ^c	16	13,9	30,5		
23 ^c	16 ^d	14,4	31,3		
24	16	14,9	33	45	
25 ^c	18 ^d	14,9	33,5		
27	20	15,9	36,7	39	50

^a $t_{\min} = m_{\max} + 0,1$; where m_{\max} is the maximum height of the nut, according to ISO 4032.

^b The maximum thread diameter, D_{\max} , is the largest nominal thread diameter found in current International Standards like, for example, ISO 4014, ISO 4032 and ISO 272.

^c Nominal dimension not covered by ISO 272.

^d Value determined in order to avoid reduction in hole clearance size.

Table 4 — Retaining pin

Driving square	<i>d</i> ₃	
	min. mm	max. mm
6,3	1,4	2,0
10	2,4	2,9
12,5	2,9	4

Table 5 — Retaining ring

Driving square	<i>d</i> ₄	
	min. mm	max. mm
6,3	2,5	6,3
10	3,5	10
12,5	4	12,5

6 Designation

A machine-operated, non-impact square drive socket, conforming to this document shall be designated by

- a) "Hex non-impact socket" or "Bi-hex non-impact socket" according to the insert,
- b) a reference to this document, i.e. ISO 2725-3,
- c) dimensions of the square drive, in millimetres, and
- d) width across the flats, in millimetres.

EXAMPLE A double hexagon (bi-hex) machine-operated square drive socket "non-impact" with 12,5 mm square drive size and with width across flats of 10 mm is designated as follows:

Bi-hex non-impact socket ISO 2725-3, 12,5 × 10

7 Marking

The machine-operated square drive non-impact socket shall be marked, permanently and legibly, with at least the following:

- a) the value of the dimension across the flats;
- b) the name or trade mark of the manufacturer or supplier;
- c) the indication "NON-IMPACT" (in block capitals).

(standards.iteh.ai)

[ISO 2725-3:2017](https://standards.iteh.ai/catalog/standards/sist/d4e85a78-277e-4f88-9a69-13ceea2f983c/iso-2725-3-2017)

<https://standards.iteh.ai/catalog/standards/sist/d4e85a78-277e-4f88-9a69-13ceea2f983c/iso-2725-3-2017>