



SLOVENSKI STANDARD
SIST ISO 2140:1997

01-marec-1997

Naprave za kontinuirni transport sipkih materialov - Členkasti transporterji

Continuous mechanical handling equipment for loose bulk materials -- Apron conveyors

Engins de manutention continue pour produits en vrac -- Transporteurs à palettes métalliques

(standards.iteh.ai)

Ta slovenski standard je istoveten z: ISO 2140:1975

<https://standards.iteh.ai/catalog/standards/sist/724550d2-3c22-4e2a-90dd-93558ce0b776/sist-iso-2140-1997>

ICS:

53.040.10 Transporterji Conveyors

SIST ISO 2140:1997

en

iTeh STANDARD PREVIEW
(standards.iteh.ai)

SIST ISO 2140:1997

<https://standards.iteh.ai/catalog/standards/sist/724550d2-3c22-4e2a-90dd-93558ce0b776/sist-iso-2140-1997>

INTERNATIONAL STANDARD**2140**

INTERNATIONAL ORGANIZATION FOR STANDARDIZATION • МЕЖДУНАРОДНАЯ ОРГАНИЗАЦИЯ ПО СТАНДАРТИЗАЦИИ • ORGANISATION INTERNATIONALE DE NORMALISATION

Continuous mechanical handling equipment for loose bulk materials — Apron conveyors

Engins de manutention continue pour produits en vrac — Transporteurs à palettes métalliques

iTeh STANDARD PREVIEW

First edition — 1975-10-15

(standards.iteh.ai)

[SIST ISO 2140:1997](#)

<https://standards.iteh.ai/catalog/standards/sist/724550d2-3c22-4e2a-90dd-93558ce0b776/sist-iso-2140-1997>

UDC 621.867.1

Ref. No. ISO 2140-1975 (E)

Descriptors : handling equipment, continuous handling, bulk products, conveyors, apron conveyors, specifications, dimensions.

FOREWORD

ISO (the International Organization for Standardization) is a worldwide federation of national standards institutes (ISO Member Bodies). The work of developing International Standards is carried out through ISO Technical Committees. Every Member Body interested in a subject for which a Technical Committee has been set up has the right to be represented on that Committee. International organizations, governmental and non-governmental, in liaison with ISO, also take part in the work.

Draft International Standards adopted by the Technical Committees are circulated to the Member Bodies for approval before their acceptance as International Standards by the ISO Council.

Prior to 1972, the results of the work of the Technical Committees were published as ISO Recommendations; these documents are now in the process of being transformed into International Standards. As part of this process, Technical Committee ISO/TC 101 has reviewed ISO Recommendation R 2140 and found it technically suitable for transformation. International Standard ISO 2140 therefore replaces ISO Recommendation R 2140:1971 to which it is technically identical.

ISO Recommendation R 2140 was approved by the Member Bodies of the following countries :

Austria	India	Sweden
Belgium	Ireland	Thailand
Czechoslovakia	Japan	Turkey
Egypt, Arab Rep. of	Netherlands	United Kingdom
France	South Africa, Rep. of	U.S.S.R.
Germany	Spain	

No Member Body expressed disapproval of the Recommendation.

No Member Body disapproved the transformation of ISO/R 2140 into an International Standard.

Continuous mechanical handling equipment for loose bulk materials – Apron conveyors

1 SCOPE AND FIELD OF APPLICATION

This International Standard specifies the main dimensions concerning the construction of apron conveyors for loose bulk materials, namely : pitch of chain, width of apron, and height of cheek plates. Practical examples are given in figure 2.



FIGURE 1 – General plan

2 SPECIFICATIONS

The following dimensions are given in millimetres.

2.1 Pitch P of chain

P	63	80	100	125	160	200	250	315	400	500
-----	----	----	-----	-----	-----	-----	-----	-----	-----	-----

2.2 Width B of apron

B	160	200	250	315	400	500	630	800	1000	1250	1600	2000	2500
-----	-----	-----	-----	-----	-----	-----	-----	-----	------	------	------	------	------

2.3 Height H of cheek plates

H	40	50	63	80	100	125	160	200	250	315	400	500
-----	----	----	----	----	-----	-----	-----	-----	-----	-----	-----	-----

NOTE – Other values for the pitch of chain, width and height of apron may be taken from the R 10 or R 20 series of preferred numbers¹⁾.

2.4 Width of track

The width of track is not standardized, as, in addition to depending on the width of apron B , it also depends on the kind of load conveyed and the means of fixing the wheels.

1) See ISO 3, *Preferred numbers – Series of preferred numbers*.

3 PRACTICAL APPLICATIONS

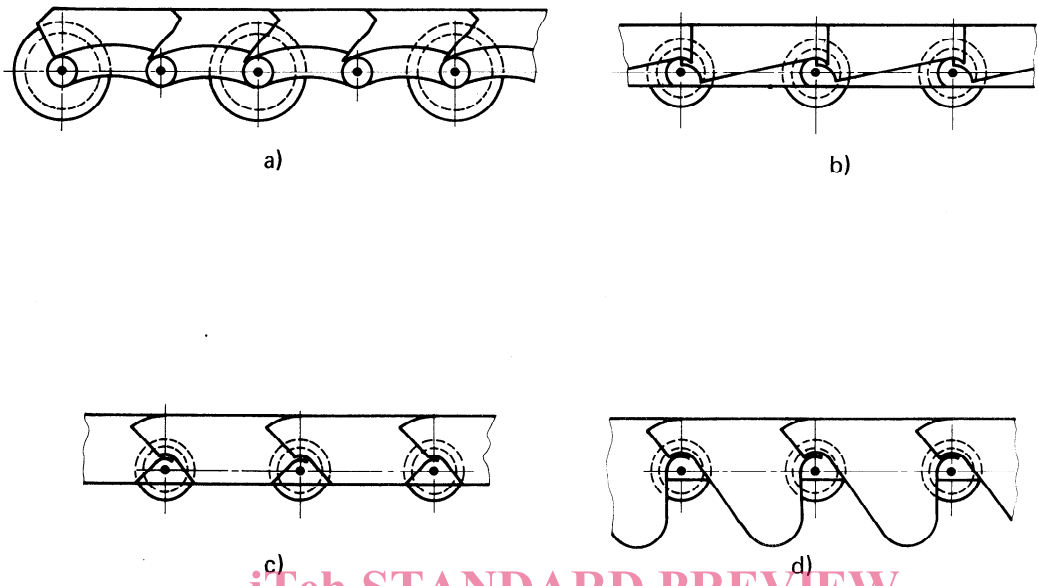

FIGURE 2 Some examples
STANDARD PREVIEW
(standards.iteh.ai)

SIST ISO 2140:1997
<https://standards.iteh.ai/catalog/standards/sist/724550d2-3c22-4e2a-90dd-93558cc0b776/sist-iso-2140-1997>