



Designation: A987/A987M – 09

Standard Practice for Measuring Shape Characteristics of Tin Mill Products¹

This standard is issued under the fixed designation A987/A987M; the number immediately following the designation indicates the year of original adoption or, in the case of revision, the year of last revision. A number in parentheses indicates the year of last reapproval. A superscript epsilon (ϵ) indicates an editorial change since the last revision or reapproval.

1. Scope*

1.1 Shape is a significant quality characteristic for tin mill products. Plate-shape is affected by mill process factors plus the temper, thickness and width of the material supplied. It is the purpose of this practice to define accurately the different plate shape characteristics and to describe the practice(s) most commonly used to measure particular characteristics.

1.2 Quantitative limits are not addressed and should be established on an individual producer and user basis, where appropriate.

1.3 The values stated in either in-pound or SI units are to be regarded as standard. Within the text, the SI units are shown in brackets. The values stated in each system must be used independently of the other. Combining values from the two systems may result in nonconformance with this specification.

1.4 *This standard does not purport to address the safety concerns, if any, associated with its use. It is the responsibility of the user of this standard to establish appropriate safety and health practices and to determine the applicability of regulatory limitations prior to use.*

2. Referenced Documents

- 2.1 *ASTM Standards*:²
- [A599/A599M Specification for Tin Mill Products, Electrolytic Tin-Coated, Cold-Rolled Sheet](#)
 - [A623 Specification for Tin Mill Products, General Requirements](#)
 - [A623M Specification for Tin Mill Products, General Requirements \[Metric\]](#)
 - [A624/A624M Specification for Tin Mill Products, Electrolytic Tin Plate, Single Reduced](#)
 - [A625/A625M Specification for Tin Mill Products, Black Plate, Single-Reduced](#)

¹ This practice is under the jurisdiction of ASTM Committee A01 on Steel, Stainless Steel and Related Alloys and is the direct responsibility of Subcommittee A01.20 on Tin Mill Products.

Current edition approved May 1, 2009. Published June 2009. Originally approved in 1998. Last previous edition approved in 2007 as A987 - 07. DOI: 10.1520/A0987_A0987M-09.

² For referenced ASTM standards, visit the ASTM website, www.astm.org, or contact ASTM Customer Service at service@astm.org. For *Annual Book of ASTM Standards* volume information, refer to the standard's Document Summary page on the ASTM website.

- [A626/A626M Specification for Tin Mill Products, Electrolytic Tin Plate, Double Reduced](#)
- [A650/A650M Specification for Tin Mill Products, Black Plate, Double Reduced](#)
- [A657/A657M Specification for Tin Mill Products, Black Plate Electrolytic Chromium-Coated, Single and Double Reduced](#)

3. Classification

3.1 The substrate shall conform to all the requirements of the appropriate specifications as follows: Specifications [A623](#), [A623M](#), [A599/A599M](#), [A624/A624M](#), [A625/A625M](#), [A626/A626M](#), [A650/A650M](#), and [A657/A657M](#).

4. Significance and Use

4.1 The definitions and procedures for measuring shape characteristics of tin mill products are provided so that purchasers and suppliers have common measuring procedures and definitions of shape characteristics. These procedures provide definitions and measuring techniques of shape characteristics. The intention of these definitions and measuring practices is not to provide a dimensional specification for shape characteristics, but rather common procedure(s) for quantifying shape anomalies.

5. Interferences

5.1 Measurement of shape often has been subjective, at best. Successful measurement of various shape anomalies on quantitative terms requires recognition of several factors that can interfere with accurate measurements.

5.1.1 Flat surfaces are required. Measurement of several anomalies require laying of the sample on a flat surface. A machined flat surface is recommended. Laying a sample on a floor may introduce error due to areas on a floor that are not flat.

5.1.2 Several anomalies are measured by hanging the sheet. Hanging by holding the sample with a hand can introduce error from pressures exerted by fingers. A mechanical single device clamp to help hold these samples is recommended.

5.1.3 Stepblock gauges or tapered gauges should be checked regularly with a calibrated hand micrometer. Wear or dirt build up could affect accuracy.

*A Summary of Changes section appears at the end of this standard

5.1.4 Computer-based shape measuring instruments must be clean and the sensors must be in good condition. The sheet sample must be damage free.

6. Apparatus

6.1 Appropriate tools to measure shape anomalies are described along with drawings (attached) as required.

6.1.1 *Flat Surfaces*— Accurate measurements of shape anomalies require a flat surface, machined flat preferred.

6.1.2 *Machined Stepblock Gauge*—See Fig. 1, typically, steps are in 1/16-in. increments.

6.1.3 *Tapered Gauge*— See Fig. 2.

6.1.4 *Standard Ruler or Tape Measure*.

6.1.5 *Hand Micrometer*.

6.1.6 *Shape Test Jig*—Fig. 3, or other shape test jigs of appropriate design.

6.1.7 *Light-Weight Straight-Edge*.

6.1.8 *Computer-based Shape Measuring Instruments* are designed for flatness measurements on samples of cold rolled sheet products or tin mill products.

7. Procedure

Definitions and Measuring Practices of Shape Anomalies

7.1 *Wavy Edge* (See Fig. 4):

7.1.1 *Definition*—A series of rolling direction edge deviations from a recognized flat surface. When a sample is placed on a recognized flat table, wavy edges will appear as undulations along the edge, having the height (A) and a measurable cycle (B). This defect can be quantified using the “I” unit (see Section 8) or steepness calculations.

7.1.2 *Measuring Practices*:

7.1.2.1 A sample of approximately 3 ft [0.9 m] in length by coil width is placed on a flat table. Measure the height (A) at the peak point of each wave from the recognized flat surface with a tapered gauge or a stepblock gauge. Also measure the cycle length (B) from peak to peak of each wave with a ruler or tape measure.

7.1.2.2 Measure using a computer-based shape measuring instrument or other instrument of appropriate design.

7.2 *Ridge Buckle, Quarter Buckle, Center Buckle* (see Fig. 5):

7.2.1 *Definition*—These buckles are continuous deviations from a recognized flat surface occurring usually in narrow width areas parallel to the rolling direction other than at the sheet edges.

7.2.2 *Measuring Practices*:

7.2.2.1 A sheet sample of approximately 3 ft [0.9 m] by coil width is placed on a flat table. Push material diagonally along the sample to within 4 in. [10 cm] of the selected corner and measure the vertical uplift using a tapered gauge or a stepblock gauge.

7.2.2.2 Shear through the center line of the shape anomaly and measure as an edge wave using a tapered gauge or a stepblock gauge.

7.2.2.3 Measure using a computer-based shape measuring instrument or other instrument of appropriate design.

7.3 *Full Center* (see Fig. 6):

7.3.1 *Definition*—Any overall deviation of a sheet from a recognized flat surface occurring over a major portion of the sheet width parallel to the rolling direction other than at the sheet edges.

7.3.2 *Measuring Practices*:

7.3.2.1 A sheet sample of approximately 3 ft [0.9 m] by coil width is placed on a flat table. Push material diagonally along the sample until the maximum lift occurs at the selected corner and measure the vertical uplift using a tapered gauge or a stepblock gauge, or a standard ruler.

7.3.2.2 Shear through the center line of the shape anomaly and measure as an edge wave using a tapered gauge or a stepblock gauge.

7.3.2.3 Measure using a computer-based shape measuring instrument or other instrument of appropriate design.

7.4 *Edge Lift* (see Fig. 7):

7.4.1 *Definition*—Any deviation of one sheet edge other than a wavy edge. This edge lift is parallel to the rolling direction and rises when placed on a recognized flat surface.

7.4.2 *Measuring Practice*— A sheet sample of approximately 3 ft [0.9 m] by coil width is placed on a flat table. Push material diagonally along the sheet until the maximum lift occurs at the selected edge and measure the vertical distance (A) with a tapered gauge, a stepblock gauge, or a standard ruler.

7.5 *Coil Set and Reverse Coil Set* (see Fig. 8):

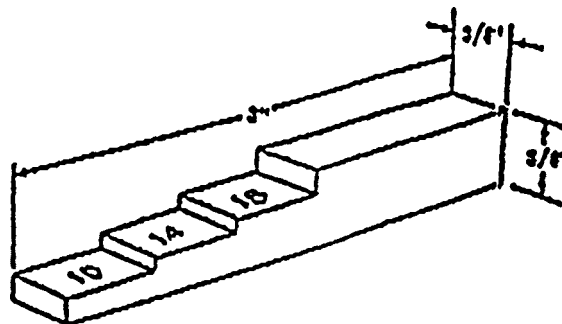

NOTE 1—This is a stepblock gauge for all thicknesses and sizes of cut sheets.

NOTE 2—Dimensions given are approximate overall dimensions.

FIG. 1 Shape Stepblock Gauge

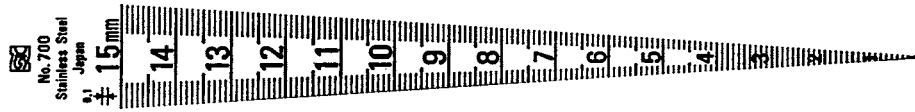

NOTE 1—This is a tapered gauge for all thicknesses and sizes of cut sheets.

FIG. 2 Shape Tapered Gauge

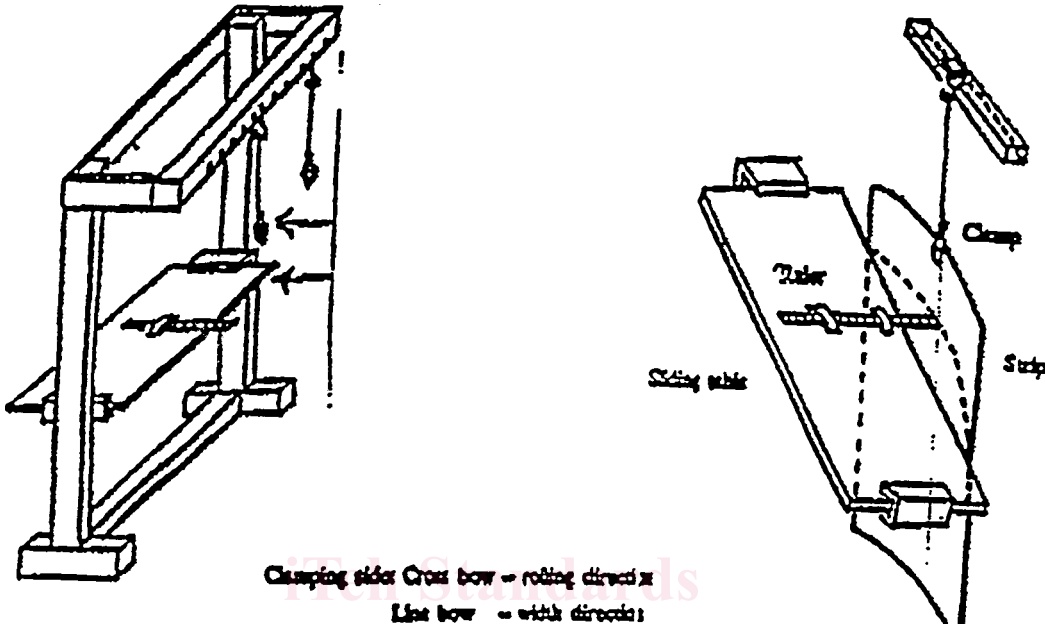

NOTE 1—To measure line bow (up or down) requires the use of a shape test jig.

FIG. 3 Shape Test Jig

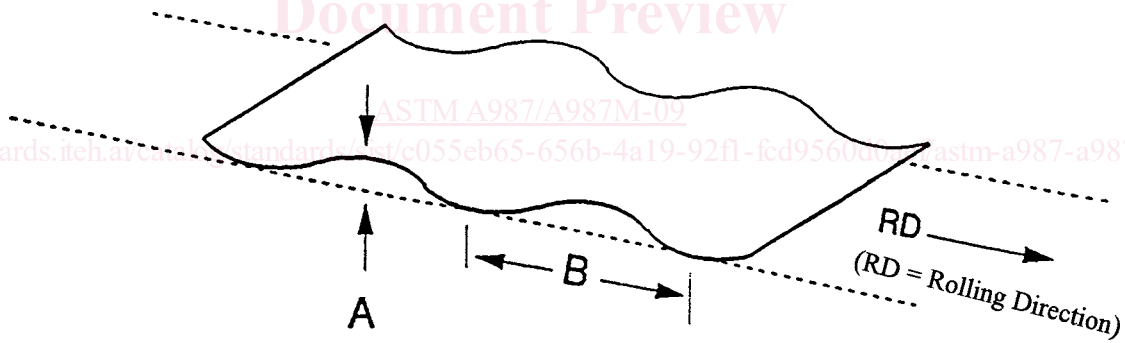

FIG. 4 Wavy Edge

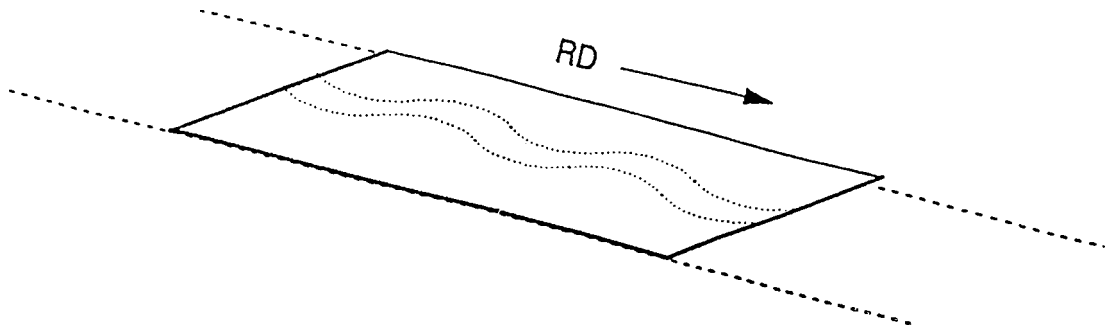

FIG. 5 Ridge Buckle, Quarter Buckle, Center Buckle

7.5.1 *Definition*—A bow condition or deviation in the sheet as measured from a recognized flat surface. The deviation runs

parallel with the rolling direction and takes the shape of a coil. Reverse coil set reverses the shape of a coil. The degree of coil

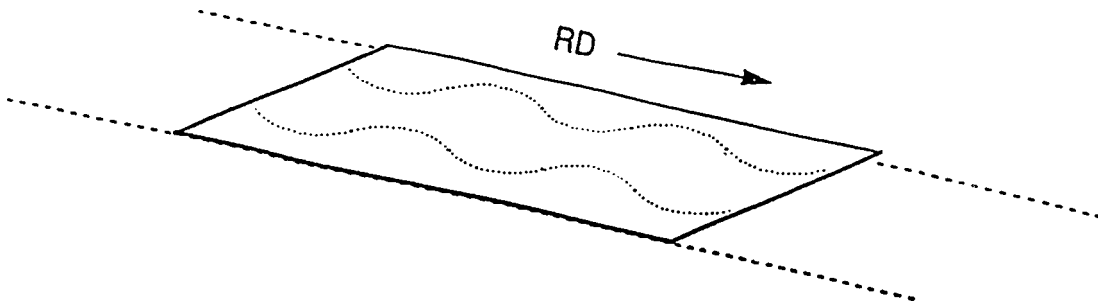

FIG. 6 Full Center

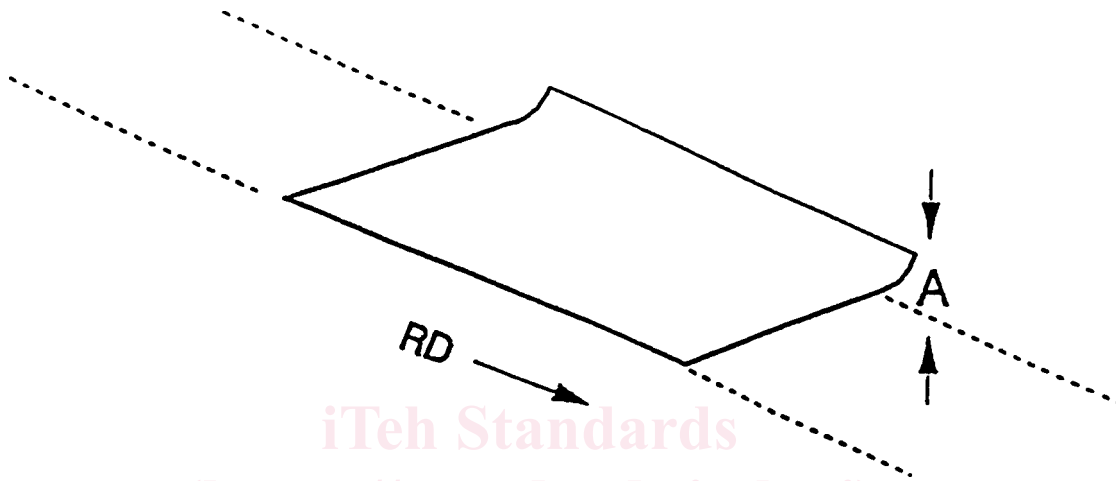

FIG. 7 Edge Lift

set usually is determined in a vertical, free-hanging position when held against a straight-edge. Use of the shape test jig (Fig. 3) is highly recommended for this measurement.

7.5.2 Measuring Practices:

7.5.2.1 A sheet sample of approximately 3 ft [0.9 m] by coil width should be held by a clamp or with the thumb and index finger. Hold the sample in the center of the rolling direction dimension. Hold the sample's edges against a recognized straight edge, and measure the deviation (A) from the edge to the center of the sample. Use a rule accurate to 1/16 in. [or 1 mm].

7.5.2.2 Measure the edge rise (A) of the sheet laying on a recognized flat surface.

7.6 Twist (see Fig. 9):

7.6.1 Definition—A combination of shape anomalies that results in a twisting of the sheet where diagonal corners will bow in opposite directions when the sheet is held in a vertical, free-hanging position.

7.6.2 Measuring Practices:

7.6.2.1 A sheet sample of approximately 3 ft [0.9 m] by coil width should be placed on a flat table. Measure the edge lift (A) on one side then turn the sheet over and measure the edge lift on the other side of the sample. Measure using a tapered gauge or a stepblock gauge.

7.6.2.2 A sheet sample of approximately 3 ft [0.9 m] by coil width should be held by a clamp or with the thumb and index finger in the center of the rolling direction dimension. Measure the amount of the twist by the deviation of one of the corners

from a flat surface using a ruler. Flip the sample 180° and measure the deviation from vertical of the other corner, using a ruler.

7.7 Crossbow (see Fig. 10):

7.7.1 Definition—An edge deviation in the sheet running perpendicular to the rolling direction. Both rolling direction edges are raised measurable amounts (A) from a recognized flat surface. The degree of cross bow usually is determined in a vertical, free-hanging position held against a straight edge. Use of the shape test jig (Fig. 3) is highly recommended for this measurement.

7.7.2 Measuring Practices:

7.7.2.1 A sheet sample of approximately 3 ft [0.9 m] by coil width should be held by a clamp or with the thumb and the index finger in the center of sheet dimension that is perpendicular to the rolling direction. In case of dispute, a clamp no more than 2 in. [50.8 mm] wide shall be used to hold the test sample. Hold the sample's edges against a recognized straight edge, and measure the deviation (A) from the straight edge to center of the sample. Use a rule accurate to 1/16 in. [or 1 mm].

7.7.2.2 Measure the edge rise of a sheet lying on a flat surface.

7.8 Camber (see Fig. 11):

7.8.1 Definition—The greatest deviation of a coil edge from a straight line. The measurement is taken on the concave side and is the perpendicular distance from a straight line to the point of maximum deviation (A).