



SLOVENSKI STANDARD
SIST EN 16922:2018+A1:2019

01-september-2019

**Železniške naprave - Talna oskrba - Oprema vozil za odvoz odpadnih voda
(vključno z dopnilom A1)**

Railway applications - Ground based services - Vehicle waste water discharge
equipment

Bahnanwendungen - Versorgungsdienste - Fahrzeugabwasserentsorgungseinrichtungen

Applications ferroviaires - Services au sol - Equipement de vidange des eaux usées des
véhicules

iTeh STANDARD PREVIEW
(standards.iten.si)

[SIST EN 16922:2018+A1:2019](https://standards.iten.si/catalog/standards/sist-en-16922-2018-a1-2019)

Ta slovenski standard je istoveten z: EN 16922:2017+A1:2019

<https://standards.iten.si/catalog/standards/sist-en-16922-2018-a1-2019>

ICS:

13.060.30	Odpadna voda	Sewage water
45.060.20	Železniški vagoni	Trailing stock

SIST EN 16922:2018+A1:2019

en,fr,de

iTeh STANDARD PREVIEW
(standards.iteh.ai)

SIST EN 16922:2018+A1:2019

<https://standards.iteh.ai/catalog/standards/sist/421d53d9-889c-42bd-a507-13b5b8ee09e3/sist-en-16922-2018a1-2019>

EUROPEAN STANDARD

EN 16922:2017+A1

NORME EUROPÉENNE

EUROPÄISCHE NORM

June 2019

ICS 45.060.20

English Version

Railway applications - Ground based services - Vehicle waste water discharge equipment

Applications ferroviaires - Services au sol - Equipement
de vidange des eaux usées des véhiculesBahnanwendungen - Versorgungsdienste -
Fahrzeugabwasserentsorgungseinrichtungen

This European Standard was approved by CEN on 28 August 2017 and includes Amendment 1 approved by CEN on 16 April 2019.

CEN members are bound to comply with the CEN/CENELEC Internal Regulations which stipulate the conditions for giving this European Standard the status of a national standard without any alteration. Up-to-date lists and bibliographical references concerning such national standards may be obtained on application to the CEN-CENELEC Management Centre or to any CEN member.

This European Standard exists in three official versions (English, French, German). A version in any other language made by translation under the responsibility of a CEN member into its own language and notified to the CEN-CENELEC Management Centre has the same status as the official versions.

CEN members are the national standards bodies of Austria, Belgium, Bulgaria, Croatia, Cyprus, Czech Republic, Denmark, Estonia, Finland, France, Germany, Greece, Hungary, Iceland, Ireland, Italy, Latvia, Lithuania, Luxembourg, Malta, Netherlands, Norway, Poland, Portugal, Republic of North Macedonia, Romania, Serbia, Slovakia, Slovenia, Spain, Sweden, Switzerland, Turkey and United Kingdom.



EUROPEAN COMMITTEE FOR STANDARDIZATION
COMITÉ EUROPÉEN DE NORMALISATION
EUROPÄISCHES KOMITEE FÜR NORMUNG

CEN-CENELEC Management Centre: Rue de la Science 23, B-1040 Brussels

Contents

Page

European foreword.....	3
1 Scope.....	4
2 Normative references.....	4
3 Terms and definitions.....	4
4 General.....	5
4.1 Description of vacuum.....	5
4.2 Description of controlled emission toilet systems.....	5
5 Requirements.....	5
5.1 General requirements.....	5
5.2 Vehicle requirements.....	6
5.2.1 Connections.....	6
5.2.2 System design.....	10
5.2.3 Temperature of operation.....	10
5.2.4 Pipework.....	11
5.2.5 Retention tank.....	12
5.2.6 Venting system.....	14
5.2.7 Sink waste.....	14
5.2.8 Test for leakage.....	14
5.3 Infrastructure requirements.....	14
5.3.1 General.....	14
5.3.2 System design.....	14
5.3.3 Connection.....	15
5.3.4 Flushing.....	15
5.3.5 Breakaway coupling.....	15
5.3.6 Pipework.....	15
5.3.7 Chemical storage.....	15
5.4 Information and instruction.....	15
5.4.1 For railway vehicles.....	15
5.4.2 For fixed installations (this includes mobile ground based installations).....	16
Annex A (informative) Generic types of toilet retention systems.....	17
Annex ZA (informative) Relationship between this European Standard and the Essential Requirements of EU Directive 2008/57/EC aimed to be covered.....	22
Bibliography.....	24

European foreword

This document (EN 16922:2017+A1:2019) has been prepared by Technical Committee CEN/TC 256 "Railway applications", the secretariat of which is held by DIN.

This European Standard shall be given the status of a national standard, either by publication of an identical text or by endorsement, at the latest by December 2019, and conflicting national standards shall be withdrawn at the latest by December 2019.

Attention is drawn to the possibility that some of the elements of this document may be the subject of patent rights. CEN shall not be held responsible for identifying any or all such patent rights.

This document includes Amendment 1 approved by CEN on 16 April 2019.

This document supersedes A1 EN 16922:2017 A1.

The start and finish of text introduced or altered by amendment is indicated in the text by tags A1 A1.

This document has been prepared under a mandate given to CEN by the European Commission and the European Free Trade Association, and supports essential requirements of EU Directive 2008/57/EC.

For relationship with EU Directive 2008/57/EC, see informative Annex ZA, which is an integral part of this document.

According to the CEN-CENELEC Internal Regulations, the national standards organizations of the following countries are bound to implement this European Standard: Austria, Belgium, Bulgaria, Croatia, Cyprus, Czech Republic, Denmark, Estonia, Finland, France, Germany, Greece, Hungary, Iceland, Ireland, Italy, Latvia, Lithuania, Luxembourg, Malta, Netherlands, Norway, Poland, Portugal, Republic of North Macedonia, Romania, Serbia, Slovakia, Slovenia, Spain, Sweden, Switzerland, Turkey and the United Kingdom.

EN 16922:2017+A1:2019 (E)

1 Scope

This European Standard specifies the interface requirements for controlled emission toilet equipment on railway vehicles and the infrastructure, including catering area sink waste retention tanks. Vehicle and infrastructure specific requirements are also given.

The European Standard includes fixed and portable infrastructure equipment used to empty retention tanks, but excludes equipment fitted to railway vehicles where no fixed connections are used between vehicle and infrastructure.

2 Normative references

The following documents, in whole or in part, are normatively referenced in this document and are indispensable for its application. For dated references, only the edition cited applies. For undated references, the latest edition of the referenced document (including any amendments) applies.

EN 1717, *Protection against pollution of potable water in water installations and general requirements of devices to prevent pollution by backflow*

EN 12663-1, *Railway applications - Structural requirements of railway vehicle bodies - Part 1: Locomotives and passenger rolling stock (and alternative method for freight wagons)*

EN 15877-2:2013, *Railway applications - Markings of railway vehicles - Part 2: External markings on coaches, motive power units, locomotives and on track machines*

EN 16362:2013, *Railway applications - Ground based services - Water restocking equipment*

EN 45545-2, *Railway applications - Fire protection on railway vehicles - Part 2: Requirements for fire behaviour of materials and components*

[SIST EN 16922:2018+A1:2019
https://standards.iteh.ai/catalog/standards/sist/421d53d9-889c-42bd-a507-13b5b8ee09e3/sist-en-16922-2018a1-2019](https://standards.iteh.ai/catalog/standards/sist/421d53d9-889c-42bd-a507-13b5b8ee09e3/sist-en-16922-2018a1-2019)

3 Terms and definitions

For the purposes of this document, the following terms and definitions apply.

3.1

railway infrastructure

all installations required for the running of railway vehicles including operating and support facilities

EXAMPLE Tracks, crossings, catenaries, signals, maintenance depots.

3.2

grey water

waste water from hand wash and galley sinks, usually contaminated with soap, germicides, residues of food, drink and dish water

3.3

servicing point

location where maintenance, refuelling and cleaning is carried out

3.4

controlled emission toilet

toilet system where the toilet waste is retained on the vehicle and emptied at prescribed locations, including on board waste treatment systems which are permitted to discharge some wastes at various locations

4 General

4.1 Description of vacuum

Vacuum can be expressed in different manners. Absolute vacuum is 0 bar and atmospheric pressure is nominally 1 bar (although this varies). When a vacuum pump evacuates 0,2 bar from a tank the remaining pressure within the tank is 0,8 bar (if the atmospheric pressure is 1 bar), but this can be expressed in a variety of ways. Therefore to avoid doubt, because the atmospheric pressure varies, throughout this standard vacuum is expressed as a negative number of bars below atmosphere (i.e. in the above example this is expressed within this standard as -0,2 bar).

Positive pressure is expressed as bars above atmosphere, i.e. in this standard an absolute pressure of 3 bar is shown as +2 bar.

4.2 Description of controlled emission toilet systems

There are five generic types of controlled emission toilets fitted to railway vehicles considered in this standard, shown diagrammatically in Annex A.

5 Requirements

5.1 General requirements

Each vehicle and servicing point shall be clearly marked with the type of system that is fitted, or intended to be used for. Adjacent to the connection on the vehicle and infrastructure the background, or if there is no background, an area beside the connection with a minimum dimension 60 mm x 60 mm, shall be coloured as shown in Table 1 and marked with the wording shown in Table 1 in the native language of the servicing point or the home depot of the vehicle and also at least in English. The labels shall be in a contrasting colour to the background colour.

<https://standards.iteh.ai/catalog/standards/sist/421d53d9-889c-42bd-a507-130368cc09e3/sist-en-16922-2018a1-2019>
Table 1 – Identification of toilet system

Type of system	Background colour The size of background colour shall be at least 60 mm x 60 mm:	Wording of label beside 3" connection	Wording of label beside 1" connection	Wording of label beside high pressure water connection
Compact system	Green	Toilet discharge	Flushing pipe	Not applicable
On line vacuum	Green	Toilet discharge	Flushing pipe	Not applicable
Permanent vacuum	Red	Toilet discharge, ensure ventilation is open	Flushing pipe	Not applicable
Chemical	Blue	Chemical toilet discharge	Flushing and chemical addition	Not applicable
On board waste treatment (e.g. bioreactor)	Yellow	On board waste treatment toilet discharge and cleaning	On board waste treatment water inlet and suction	On board waste treatment high pressure water
Catering area sink waste retention	Grey	Catering area sink waste	Not applicable	Not applicable

EN 16922:2017+A1:2019 (E)

The position on a vehicle of the background colour and labels described in Table 1 is shown diagrammatically in Figure 1.

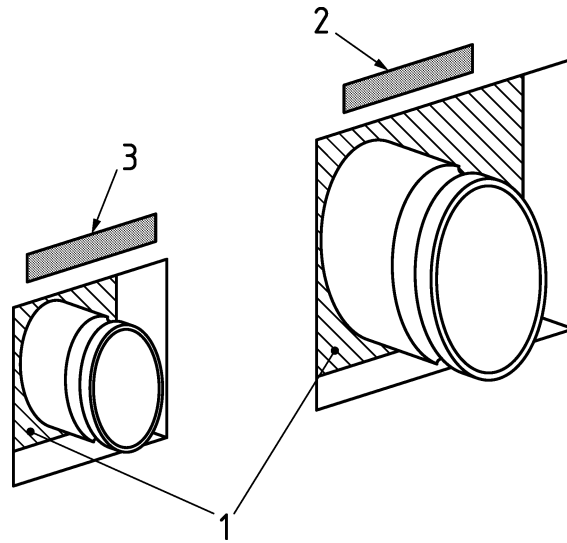
**Key**

- 1 background colour of type of system (as shown in Table 1)
- 2 label beside 3" connection
- 3 label beside 1" connection

Figure 1 — Identification of connections on vehicle

On the label shown in Figure 1, key 2, the volume of the retention tank in litres shall be indicated.

5.2 Vehicle requirements

5.2.1 Connections

Except for vehicles fitted with on board waste treatment system each vehicle with toilet waste or catering area sink waste retention tank shall be fitted with a connection as shown in Figure 2 on each side of vehicle. Vehicles fitted with on board waste treatment system are permitted to have the 3" connection on one side, but it is preferable to have on both sides.

For toilet waste retention tanks each such vehicle, excluding locomotives, shall also be fitted with a flushing connection as shown in Figure 3. On vehicles fitted with a chemical toilet system (Annex A, Figure A.4) the flushing connection shall be fitted on each side of the vehicle, for all other toilet systems the flushing connection shall be as a minimum of one side of the vehicle.

As design guidance it is preferable to have the flushing connection on both sides. It is also preferable to fit flushing connections for catering area sink waste tanks. Provision of the flushing connection reduces maintenance costs and increases efficiency of cleaning operations of the tank.

Dimensions in millimetres

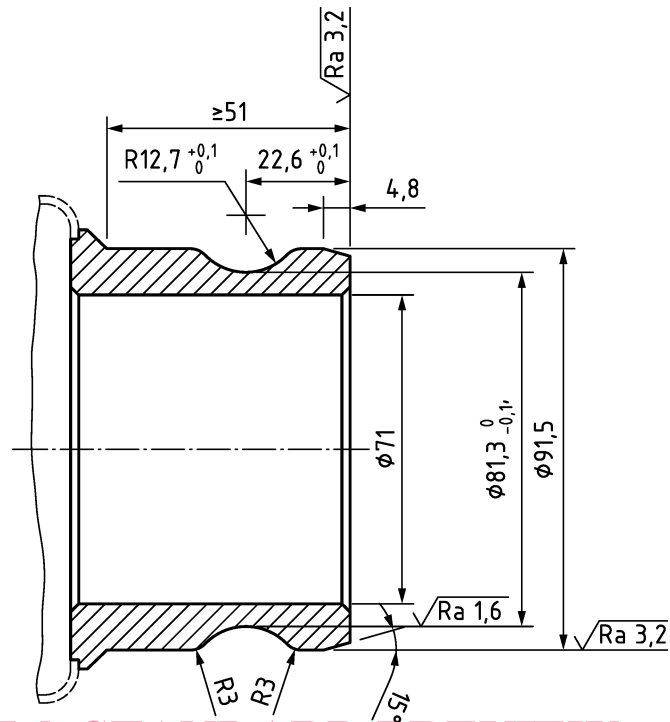
NOTE 1 General tolerances $\pm 0,1$.

NOTE 2 Material: stainless steel.

Figure 2 — 3" connection (inner part)
<https://standards.iteh.ai/catalog/standards/sist/421d53d9-889c-42bd-a507-13b5b8ee09e3/sist-en-16922-2018a1-2019>

Dimensions in millimetres

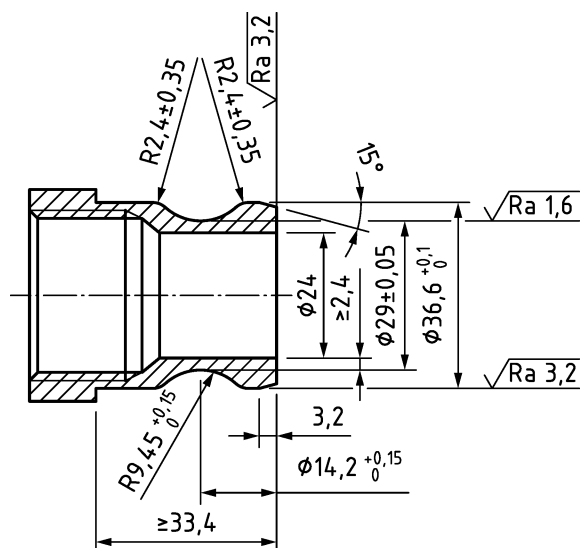
NOTE 1 General tolerances $\pm 0,1$.

NOTE 2 Material: stainless steel.

Figure 3 — 1" connection (inner part)

EN 16922:2017+A1:2019 (E)

The connections on the vehicle shall be between 500 mm and 1 500 mm above rail level, measured to the centre of the connection. They shall not be recessed further than 100 mm deeper than the vehicle bodyline. Where the connections are set back from the vehicle bodyline contained within a box structure, the floor of the box shall be sloping outwards so that water cannot be retained in the enclosed box and always drains to the outside of the vehicle. The connections shall have space around them as detailed in Figure 4 and Figure 5 to allow connection of the pipe – this does not have to be all the way around the connection but shall be for the direction the pipe connection rotates (i.e. the space around connection does not have to be circular but is permitted to be rectangular or oval). When a manual valve is included in the connection area, the space around the connection shall permit the opening and closing operations.

Dimensions in millimetres

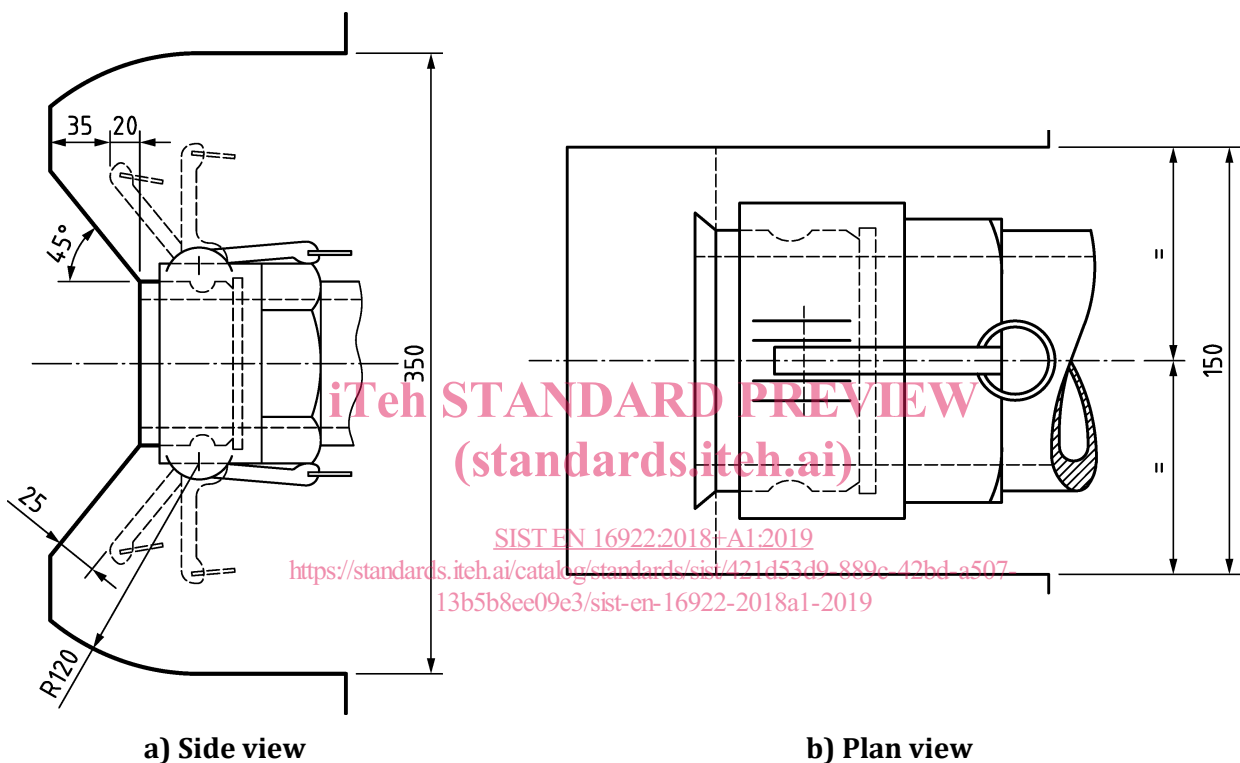

Figure 4 — Space around 3" connection

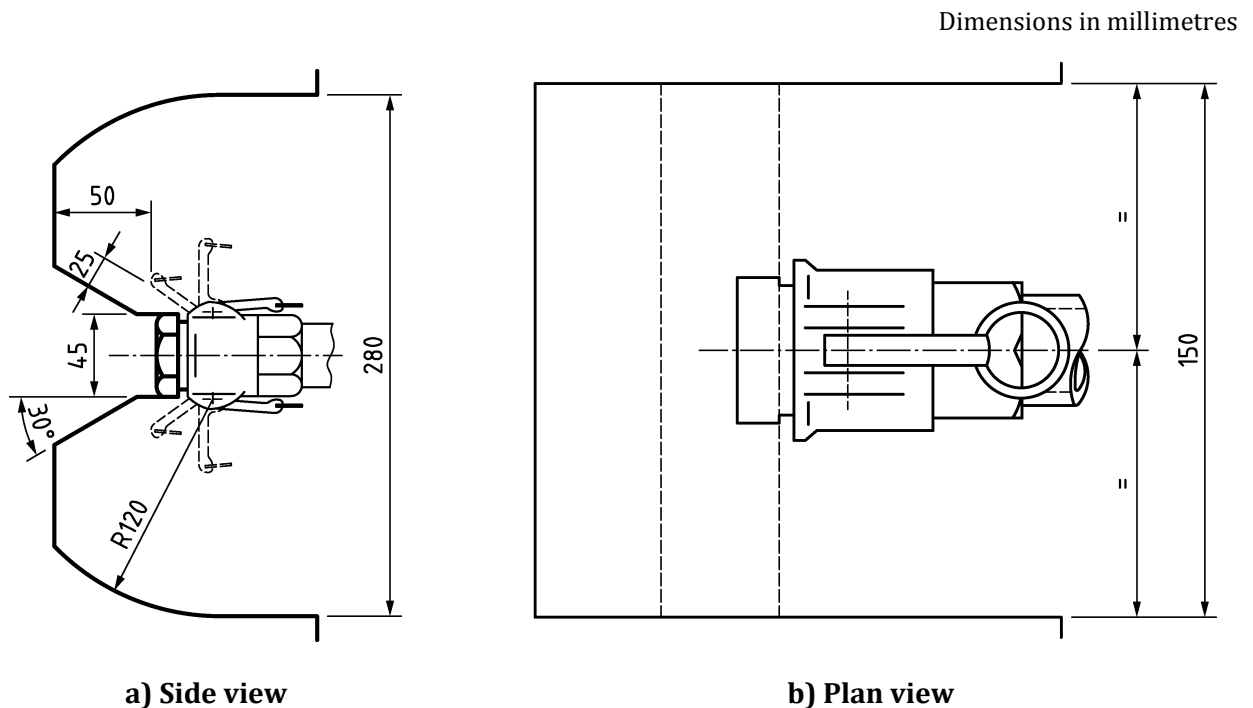

Figure 5 — Space around 1" connection

iTeh STANDARD PREVIEW

The 3" connection and 1" connection shall be separated from water filling connection, described in EN 16362, to avoid potential contamination. They shall be a minimum 500 mm apart, or separated by a mechanical barrier. The mechanical barrier shall be impervious to stop spillage from the 3" connection contaminating the water filling connection point. Where the 3" connection and water filling connection are in the same area of the vehicle (whether separated by 500 mm or a mechanical barrier) the 3" connection shall always be lower, as shown in Figure 6.

Where a mechanical barrier is fitted between 3" connection and water filling connection it shall include a cover flap that opens between the connections.

In addition to the background colour and label detailed in 5.1, the connections shall be marked as shown in EN 15877-2:2013, 4.5.16, Figure 50.