



Designation: E28 – 99 (Reapproved2009)

## Standard Test Methods for Softening Point of Resins Derived from Naval Stores by Ring-and-Ball Apparatus<sup>1</sup>

This standard is issued under the fixed designation E28; the number immediately following the designation indicates the year of original adoption or, in the case of revision, the year of last revision. A number in parentheses indicates the year of last reapproval. A superscript epsilon ( $\epsilon$ ) indicates an editorial change since the last revision or reapproval.

*This standard has been approved for use by agencies of the Department of Defense.*

### 1. Scope

1.1 These test methods are intended for determining the softening point of resins (including rosin and terpene resins) and similar materials by means of the ring-and-ball apparatus.

NOTE 1—For testing asphalts, tars, and pitches, see Test Method D36.

1.1.1 Test method using the manual ring and ball softening point apparatus, and

1.1.2 Test method using an automated ring and ball softening point apparatus.

1.2 The values stated in SI units are to be regarded as the standard. The values given in parentheses are for information only.

1.3 *This standard does not purport to address all of the safety concerns, if any, associated with its use. It is the responsibility of the user of this standard to establish appropriate safety and health practices and determine the applicability of regulatory limitations prior to use.*

### 2. Referenced Documents

2.1 *ASTM Standards:*<sup>2</sup>

D36 Test Method for Softening Point of Bitumen (Ring-and-Ball Apparatus)

E1 Specification for ASTM Liquid-in-Glass Thermometers

E177 Practice for Use of the Terms Precision and Bias in ASTM Test Methods

E691 Practice for Conducting an Interlaboratory Study to Determine the Precision of a Test Method

### 3. Significance and Use

3.1 In general, with materials of these types, softening does not take place at a definite temperature. As the temperature

<sup>1</sup> These test methods are under the jurisdiction of ASTM Committee D01 on Paint and Related Coatings, Materials, and Applications and are the direct responsibility of Subcommittee D01.34 on Pine Chemicals and Hydrocarbon Resins.

Current edition approved June 1, 2009. Published June 2009. Originally approved in 1936. Last previous edition approved in 2004 as E28 – 99 (2004). DOI: 10.1520/E0028-99R09.

<sup>2</sup> For referenced ASTM standards, visit the ASTM website, www.astm.org, or contact ASTM Customer Service at service@astm.org. For *Annual Book of ASTM Standards* volume information, refer to the standard's Document Summary page on the ASTM website.

risers, these materials gradually change from brittle or exceedingly thick and slow-flowing materials to softer and less viscous liquids. For this reason, the determination of the softening point must be made by a fixed, arbitrary, and closely defined method if the results obtained are to be comparable.

3.2 In these test methods, the softening point is defined as the temperature at which a disk of the sample held within a horizontal ring is forced downward a distance of 25.4 mm (1 in.) under the weight of a steel ball as the sample is heated at 5°C/min in a water, glycerin, silicone oil, ethylene glycol/water or glycerin/water bath.

### 4. Sample Preparation

4.1 *Preparation of Sample by the Pour Method:*

4.1.1 This procedure is suitable for materials that can be heated and poured without adverse effects on the softening point.

4.1.2 Select a sample representative of the material to be tested. The sample should consist of flakes, pastilles, or freshly broken lumps free of oxidized surfaces. Avoid inclusion of finely divided material or dust.

4.1.3 Select a quantity at least twice that necessary to fill the desired number of rings, and melt it immediately in a clean container, using an oven, hot plate, sand bath or oil bath to prevent local overheating. Take care to avoid incorporating air bubbles in the sample. Melt the sample completely, but do not heat it above a temperature necessary to pour the material readily. The time from the beginning of heating to the pouring of the sample should not exceed 15 min.

NOTE 2—For materials that may be heat sensitive, continuously inert the flask containing the test specimen with nitrogen ( $N_2$ ) during the remelting procedure.

4.1.4 For materials that tend to crack or shrink in the ring on cooling, immediately before filling the ring, preheat the ring to approximately the temperature at which the material is to be poured. The ring, while being filled, should rest bottom down on a suitable metal surface. Pour the sample into the ring so as to leave an excess on cooling. After cooling a minimum of 30 min, trim off the excess resin on the periphery of the ring. To remove excess resin from the top, cut the excess material off cleanly with a slightly heated knife or spatula, or grasp the ring

in a pair of tongs and draw the top surface quickly and firmly over the surface of a heated metal plate. In case the test is repeated, use a clean container and fresh sample.

#### 4.2 Preparation of Sample by the Molding Method:

4.2.1 See **Appendix X1**, Alternate Sample Preparation Procedures.

#### 4.3 Preparation of Samples Having a Low Softening Point (up to 35°C (95°F)):

4.3.1 Place a ring on a piece of aluminum foil. Pour the material to be tested into the ring, then place the foil and filled ring on dry ice or in a freezer to cool. The material in the ring must be free of bubbles.

4.3.2 After cooling, cut and scrape off any excess material using a slightly heated spatula, then slide the ring gently from the foil. Place the ring in the supporting apparatus, and immediately perform the softening point analysis according to Section 11.

### 5. Reagents and Materials

#### 5.1 Bath Liquids:

5.1.1 *Distilled or Deionized Water, Freshly Boiled*—For softening points between 35°C (95°F) and 80°C (176°F).

5.1.1.1 Use distilled or deionized water that has been cooled to at least 27°C (81°F) below the anticipated softening point, but in no case lower than 5°C (41°F).

5.1.2 *USP Glycerin*—For softening points between 80°C (176°F) and 150°C (302°F). Repeated use of glycerin will increase the moisture content over time and may affect results. Replace with fresh glycerin if any change in appearance is noted.

NOTE 3—Glycerin should not be used for softening points greater than 150°C (302°F) due to the 160°C (320°F) flash point of glycerin.

5.1.3 *Silicone Oil (Polydimethylsiloxane)*—For softening points above 80°C (176°F). The silicone oil must have a temperature range of 200°C + (392°F), remain clear within the temperature range, have no apparent reactivity with the test specimen, have a high water repellency, and maintain a uniform viscosity and stirring rate within the temperature range.<sup>3</sup>

NOTE 4—Replace with fresh silicone oil if any change in appearance is noted. Do not use silicone oil that contains any gels; gels are an indicator that degradation has occurred.

5.1.4 *Ethylene Glycol*—For softening points up to 35°C (95°F).

5.1.4.1 Prepare a fresh 50/50 (v/v) mixture of distilled water and ethylene glycol prior to sample analysis. For softening points between 0°C and 35°C, a 50/50 (v/v) mixture of glycerin and water may be used.

<sup>3</sup> The sole source of supply of silicone oil, 200 fluid, 50 cSt viscosity known to the committee at this time is Dow Corning Corp., Midland, MI 48686. If you are aware of alternative suppliers, please provide this information to ASTM International Headquarters. Your comments will receive careful consideration at a meeting of the responsible technical committee,<sup>1</sup> which you may attend.

### MANUAL RING AND BALL SOFTENING POINT METHOD

#### 6. Apparatus

6.1 *Ring and Ball Apparatus*, consisting of the following:

6.1.1 *Ring*—A brass, shouldered ring conforming to the dimensions shown in **Fig. 1(a)**.

6.1.2 *Ball*—A steel ball, 9.53 ± 0.1 mm ( $\frac{3}{8}$  in.) in diameter, weighing between 3.45 and 3.55 g.

6.1.3 *Ball-Centering Guide*—A brass guide for centering the ball conforming to the general shape and dimensions shown in **Fig. 1(c)**, the use of which is optional.

6.2 *Support for Ring and Thermometer*—Any convenient method for supporting the ring and thermometer may be used, provided it meets the following requirements:

6.2.1 The ring must be supported in a substantially horizontal position.

6.2.2 When using the apparatus shown in **Fig. 1(d)**: The bottom of the ring must be 25.4 ± 0.2 mm (1.0 in.) above the horizontal plate below it; the bottom surface of the horizontal plate must be 12.7 to 19.05 mm (0.5 to 0.75 in.) above the bottom of the beaker.

6.2.3 Suspend a thermometer so that the bottom of the bulb is level with the bottom of ring and within 12.7 mm (0.5 in.) but not touching the ring or the ring holder.

6.3 *Bath*—A heat-resistant glass beaker, at least 85 mm (3.34 in.) in diameter and 127 mm (5 in.) in depth from the bottom of the flare, for example, an 800-mL low-form Griffin beaker.

6.4 *Temperature Measuring Device*—A thermometer having a range described below and conforming to the requirements prescribed in Specification **E1**, or an electronic temperature measuring device, such as a resistance thermometer or thermocouple. The device must exhibit the same temperature response as the thermometers specified in Specification **E1** and must be accurately calibrated.

6.4.1 An ASTM Thermometer, having a range from –38 to +50°C (–36 to +120°F), ASTM 5C, 5F, or equivalent.

6.4.2 An ASTM Low-Softening-Point Thermometer, having a range from –2 to 80°C (30 to 180°F), ASTM 15C, 15F or equivalent.

6.4.3 An ASTM Medium-Softening Point Thermometer, having a range from 30 to 200°C (85 to 392°F), ASTM 16C, 16F or equivalent.

6.4.4 An ASTM High-Softening-Point Thermometer, having a range from –2 to 300°C (30 to 580°F), ASTM 7C, 7F or equivalent.

6.5 *Stirrer*—The heating bath must be stirred at a speed sufficient to ensure uniform heat distribution without causing significant sideways displacement of the resin as it softens in the ring. A stirring rate of 500 to 700 r/min is typical. A mechanical motor-driven stirrer, mounted so that any vibrations created by its rotation are not conveyed directly to the sample support, or a magnetic stirrer placed under the bath may be used.

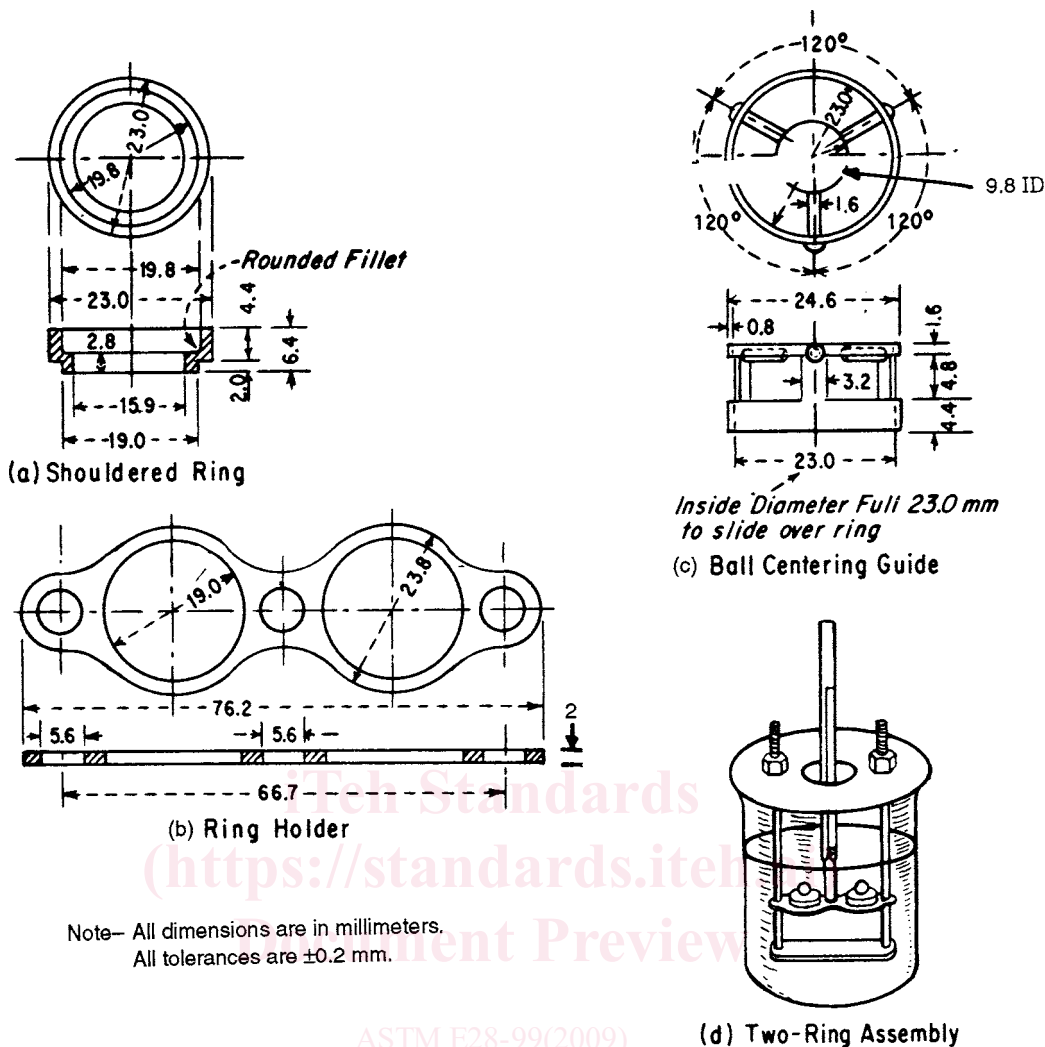

FIG. 1 Shouldered Ring, Ring Holder, Ball-Centering Guide, and Assembly of Apparatus Showing Two Rings

6.6 *Heat Source*—A heat source capable of maintaining the proper heating rate, such as a temperature controller with immersion heating coil, an electric heater or a bunsen burner.

## 7. Procedure for Materials Having a Softening Point Between 35 and $<80^{\circ}\text{C}$ (95 and $176^{\circ}\text{F}$ )

7.1 *Assembly of Apparatus*—Fill the bath with distilled or deionized water, conforming to the requirements in 5.1.1, so that the level will be  $105 \pm 3$  mm ( $4.13 \pm 0.12$  in.). If a mechanical motor-driven stirrer is used, position the axis of the stirrer shaft near the back wall of the beaker, with the blades clearing the wall and with the bottom of the blades approximately 19.0 mm (0.75 in.) above the top of the ring. If the ball-centering guide is not used, make a slight indentation in the center of the sample by pressing the ball or a rounded rod, slightly heated for hard materials, into the material at this point. Suspend the ring containing the sample in the water in the manner described in 6.2.2 or  $25.4 \pm 0.2$  mm (1 in.) above the bottom of the beaker when using the apparatus in Fig. 2(e). Center the ball on the surface of the test specimen in the ring. Suspend an ASTM low-softening-point thermometer in the bath as prescribed in 6.2.3. Maintain the initial temperature of

the water for 15 min. Start stirring, and continue stirring until completion of the determination.

7.2 *Heating*—Heat the bath so that the temperature of the water is raised uniformly at a rate of  $5^{\circ}\text{C}$  ( $10^{\circ}\text{F}$ )/min. Protect the bath from drafts, using shields if necessary. Do not average the rate of rise over the test period. The maximum permissible variation for any 1-min period after the first three minutes is  $\pm 0.5^{\circ}\text{C}$  ( $\pm 1^{\circ}\text{F}$ ). Reject any test in which the rate of temperature rise does not fall within these limits.

NOTE 5—Rigid adherence to the prescribed rate of heating is absolutely essential for reproducibility of results.

7.3 *Softening Point*—Record as the softening point the temperature of the thermometer at the instant the material touches the lower horizontal plate (Fig. 1(d)). Make no correction for the emergent stem of the thermometer.

NOTE 6—When the ball drops through the ring, it should be completely surrounded by softening resin and should drop straight down to the lower horizontal plate.

7.4 Thoroughly clean the ring holder, ball, and ring in a suitable solvent.