

© ISO 2018 – All rights reserved

ISO 1920-13:2018(E)

ISO TC 71/SC 01/WG 2

Secretariat: SII

Testing of concrete —Part 13: Properties of fresh self-compacting concrete

iTeh STANDARD PREVIEW  
(standards.iteh.ai)

[ISO 1920-13:2018](https://standards.iteh.ai/catalog/standards/sist/45b22871-c5a6-4186-9b9c-e6c850d49903/iso-1920-13-2018)

<https://standards.iteh.ai/catalog/standards/sist/45b22871-c5a6-4186-9b9c-e6c850d49903/iso-1920-13-2018>

© ISO 2017, Published in Switzerland

All rights reserved. Unless otherwise specified, no part of this publication may be reproduced or utilized otherwise in any form or by any means, electronic or mechanical, including photocopying, or posting on the internet or an intranet, without prior written permission. Permission can be requested from either ISO at the address below or ISO's member body in the country of the requester.

ISO copyright office

Ch. de Blandonnet 8 • CP 401

CH-1214 Vernier, Geneva, Switzerland

Tel. + 41 22 749 01 11

Fax + 41 22 749 09 47

copyright@iso.org

www.iso.org

iTeh STANDARD PREVIEW  
(standards.iteh.ai)

ISO 1920-13:2018

<https://standards.iteh.ai/catalog/standards/sist/45b22871-c5a6-4186-9b9c-e6c850d49903/iso-1920-13-2018>

**Contents**

**Foreword** ..... Error! Bookmark not defined.

**Introduction**..... Error! Bookmark not defined.

**1 Scope** ..... Error! Bookmark not defined.

**2 Normative references** ..... Error! Bookmark not defined.

**3 Terms and definitions**..... Error! Bookmark not defined.

**4 Slump-flow test** ..... Error! Bookmark not defined.

**4.1 General** ..... Error! Bookmark not defined.

**4.2 Principle** ..... Error! Bookmark not defined.

**4.3 Apparatus**..... Error! Bookmark not defined.

**4.3.1 Baseplate** ..... Error! Bookmark not defined.

**4.3.2 Rule or measuring tape**..... Error! Bookmark not defined.

**4.3.3 Stop watch**..... Error! Bookmark not defined.

**4.3.4 Spirit level**..... Error! Bookmark not defined.

**4.3.5 Container**..... Error! Bookmark not defined.

**4.3.6 Collar (optional)** ..... Error! Bookmark not defined.

**4.4 Test sample**..... Error! Bookmark not defined.

**4.5 Procedure**..... Error! Bookmark not defined.

**4.6 Test result** ..... Error! Bookmark not defined.

**4.7 Test report**..... Error! Bookmark not defined.

**4.8 Repeatability and reproducibility**..... Error! Bookmark not defined.

**5 V funnel test**..... Error! Bookmark not defined.

**5.1 General** ..... Error! Bookmark not defined.

**5.2 Principle** ..... Error! Bookmark not defined.

**5.3 Apparatus**..... Error! Bookmark not defined.

**5.3.1 V-funnel**..... Error! Bookmark not defined.

**5.3.2 Container** ..... Error! Bookmark not defined.

**5.3.3 Stop watch**..... Error! Bookmark not defined.

**5.3.4 Straight edge** ..... Error! Bookmark not defined.

**5.4 Test sample**..... Error! Bookmark not defined.

**5.5 Procedure**..... Error! Bookmark not defined.

**5.6 Test report** ..... Error! Bookmark not defined.

**5.7 Repeatability and reproducibility**..... Error! Bookmark not defined.

**6 L box test**..... Error! Bookmark not defined.

**6.1 General** ..... Error! Bookmark not defined.

**6.2 Principle** ..... Error! Bookmark not defined.

**6.3 Apparatus**..... Error! Bookmark not defined.

**6.3.1 L box** ..... Error! Bookmark not defined.

**6.3.2 Rule or measuring tape**..... Error! Bookmark not defined.

**6.3.3 Containers** ..... Error! Bookmark not defined.

**6.3.4 Spirit level** ..... Error! Bookmark not defined.

**6.3.5 Straight edge** ..... Error! Bookmark not defined.

**6.4 Test sample**..... Error! Bookmark not defined.

**6.5 Test procedure** ..... Error! Bookmark not defined.

**6.6 Test result** ..... Error! Bookmark not defined.

**6.7 Test report** ..... Error! Bookmark not defined.

**6.8 Repeatability and reproducibility**..... Error! Bookmark not defined.

Deleted: ¶

7 Sieve segregation test ..... Error! Bookmark not defined.

7.1 General ..... Error! Bookmark not defined.

7.2 Principle ..... Error! Bookmark not defined.

7.3 Apparatus ..... Error! Bookmark not defined.

7.3.1 Perforated plate sieve ..... Error! Bookmark not defined.

7.3.2 Balance ..... Error! Bookmark not defined.

7.3.3 Sample container ..... Error! Bookmark not defined.

7.3.4 Timer ..... Error! Bookmark not defined.

7.3.5 Thermometer ..... Error! Bookmark not defined.

7.4 Test sample ..... Error! Bookmark not defined.

7.5 Procedure ..... Error! Bookmark not defined.

7.6 Test result ..... Error! Bookmark not defined.

7.7 Test report ..... Error! Bookmark not defined.

7.8 Repeatability and reproducibility ..... Error! Bookmark not defined.

8 J-ring test ..... Error! Bookmark not defined.

8.1 General ..... Error! Bookmark not defined.

8.2 Principle ..... Error! Bookmark not defined.

8.3 Apparatus ..... Error! Bookmark not defined.

8.3.1 General ..... Error! Bookmark not defined.

8.3.2 Narrow gap J-ring ..... Error! Bookmark not defined.

8.3.3 Wide gap J-ring ..... Error! Bookmark not defined.

8.3.4 Straight edge ..... Error! Bookmark not defined.

8.4 Test sample ..... Error! Bookmark not defined.

8.5 Procedure ..... Error! Bookmark not defined.

8.6 Expression of results ..... Error! Bookmark not defined.

8.6.1 Passing ability  $P_j$  ..... Error! Bookmark not defined.

8.6.2 Flow spread  $SF_j$  ..... Error! Bookmark not defined.

8.6.3 Flow time  $t_{500j}$  ..... Error! Bookmark not defined.

8.7 Test report ..... Error! Bookmark not defined.

8.8 Repeatability and reproducibility ..... Error! Bookmark not defined.

9 Drop and fill height test for self-compactability of fresh concrete ..... Error! Bookmark not defined.

9.1 General ..... Error! Bookmark not defined.

9.2 Principle ..... Error! Bookmark not defined.

9.3 Apparatus ..... Error! Bookmark not defined.

9.4 Test sample ..... Error! Bookmark not defined.

9.5 Procedure ..... Error! Bookmark not defined.

9.6 Expression of results ..... Error! Bookmark not defined.

9.6.1 Filling time ..... Error! Bookmark not defined.

9.6.2 Filling height ..... Error! Bookmark not defined.

9.6.3 Coarse aggregate content of concrete after flowing through the obstacle (when necessary) ..... Error! Bookmark not defined.

9.7 Test report ..... Error! Bookmark not defined.

Bibliography ..... Error! Bookmark not defined.

## Foreword

ISO (the International Organization for Standardization) is a worldwide federation of national standards bodies (ISO member bodies). The work of preparing International Standards is normally carried out through ISO technical committees. Each member body interested in a subject for which a technical committee has been established has the right to be represented on that committee. International organizations, governmental and non-governmental, in liaison with ISO, also take part in the work. ISO collaborates closely with the International Electrotechnical Commission (IEC) on all matters of electrotechnical standardization.

The procedures used to develop this document and those intended for its further maintenance are described in the ISO/IEC Directives, Part 1. In particular the different approval criteria needed for the different types of ISO documents should be noted. This document was drafted in accordance with the editorial rules of the ISO/IEC Directives, Part 2 (see [www.iso.org/directives](http://www.iso.org/directives)).

Attention is drawn to the possibility that some of the elements of this document may be the subject of patent rights. ISO shall not be held responsible for identifying any or all such patent rights. Details of any patent rights identified during the development of the document will be in the Introduction and/or on the ISO list of patent declarations received (see [www.iso.org/patents](http://www.iso.org/patents)).

Any trade name used in this document is information given for the convenience of users and does not constitute an endorsement.

For an explanation on the voluntary nature of standards, the meaning of ISO specific terms and expressions related to conformity assessment, as well as information about ISO's adherence to the World Trade Organization (WTO) principles in the Technical Barriers to Trade (TBT) see the following URL: [www.iso.org/iso/foreword.html](http://www.iso.org/iso/foreword.html).

This document was prepared by Technical Committee ISO/TC 71, *Concrete, reinforced concrete and pre-stressed concrete*, Subcommittee SC 1, *Test methods for concrete*.

A list of all parts in the ISO 1920 series can be found on the ISO website.



## Testing of concrete — Part 13: Properties of fresh self-compacting concrete

### 1 Scope

This document specifies procedures for testing fresh self-compacting concrete. It specifies the following test methods: determination of consistence (slump flow test), V funnel test, L box test, **sieve** segregation test, **L**-ring test and **self**-compactability test.

Deleted: Sieve

Deleted:

Deleted: Self

### 2 Normative references

The following documents are referred to in the text in such a way that some or all of their content constitutes requirements of this document. For dated references, only the edition cited applies. For undated references, the latest edition of the referenced document (including any amendments) applies.

ISO 1920-1, *Testing of concrete — Part 1: Sampling of fresh concrete*

ISO 1920-2, *Testing of concrete — Part 2: Properties of fresh concrete*

ISO 3310-2, *Test sieves — Technical requirements and testing — Part 2: Test sieves of perforated metal plate*

### 3 Terms and definitions

For the purposes of this document, the following terms and definitions apply.

ISO and IEC maintain terminological databases for use in standardization at the following addresses:

— ISO Online browsing platform: available at <https://www.iso.org/obp>

— IEC Electropedia: available at <http://www.electropedia.org/>

Deleted: <https://www.electropedia.org/>

#### 3.1 self-compacting concrete SCC

innovative concrete that does not require vibration for placing and compaction because it is able to flow under its own weight, completely filling formwork and achieving full compaction, even in the presence of congested reinforcement

#### 3.2 passing ability

ability of fresh concrete to flow through tight openings such as spaces between steel reinforcing bars without segregation or blocking

#### 3.3 segregation resistance

ability of fresh concrete to remain homogeneous in composition while in its fresh state

#### 3.4 slump flow

mean diameter of the spread of fresh concrete from a standardized slump cone

#### 3.5

**viscosity**

<concrete> resistance to flow of fresh concrete once flow has started

**4 Slump-flow test****4.1 General**

This test specifies the procedure for determining the slump-flow and  $t_{500}$  time for self-compacting concrete. The test is not suitable when the maximum size of the aggregate exceeds 40 mm.

**4.2 Principle**

The slump-flow test is an indication of the flowability of self-compacting concrete in the absence of obstructions. It is based on the slump test described in ISO 1920-2. The flowability is evaluated by measuring the spreading maximum diameter,  $d_{\max}$ , and the time it reaches the spreading diameter of 500 mm,  $t_{500}$ . The  $d_{\max}$  of spreading is a measure of the self-compacting concrete flow range when subjected to load from its own weight. It is an indication of the yield stress of the self-compacting concrete. The  $t_{500}$  time is a measure of the speed of flow and an indication of the relative viscosity of the self-compacting concrete. The result is an indication of the filling ability of self-compacting concrete.

The fresh concrete is poured into a cone as specified for the ISO 1920-2 slump test. When the cone is withdrawn upwards, the time from commencing upward movement of the cone to when the concrete has flowed to a diameter of 500 mm is measured; this is the  $t_{500}$  time. The largest diameter of the flow spread of the concrete and the diameter of the spread at right angles to it are then measured and the mean is the slump-flow.

**4.3 Apparatus**

**4.3.1 Mould**, in accordance with ISO 1920-2:2016, 4.3.2.1 (see Figure 1).

**4.3.2 Rule or measuring tape**, of minimum length 1 000 mm and having sub-divisions not greater than 5 mm along its entire length.

**4.3.3 Stop watch**, capable of measuring to 0,1 s.

**4.3.4 Spirit level**, for checking horizontality of base plate prior to commencing the test.

**4.3.5 Container**, to hold the test sample and having a volume of at least 10 l.

**4.3.6 Collar**, (optional) having a mass of at least 9 kg (see Figure 2).

NOTE The collar allows the test to be carried out by one person.

**4.4 Test sample**

The sample shall be obtained in accordance with ISO 1920-1.

**4.5 Procedure**

Place the baseplate on a flat and horizontal surface free from external vibration or shock. Check the top surface for horizontality using the spirit level. Clean the table and the cone and dampen immediately prior to testing, but keep free from excess moisture.

Fit the collar to the cone if being used.

Place the cone centrally within the 200 mm circle on the baseplate and hold in position by standing on the foot pieces (or use the collar), ensuring that no concrete can leak from under the cone.



Fill the cone in one operation without any agitation or mechanical compaction, and strike off surplus from the top of the cone. Allow the filled cone to stand for not more than 30 s; during this time remove any spilled concrete from the baseplate.

Lift the cone vertically in 1 s to 3 s in one movement without interfering with the flow of concrete. If the  $t_{500}$  time has been requested, start the stop watch immediately the cone ceases to be in contact with the baseplate and record the time taken to the nearest 0,1 s for the concrete to first touch the 500 mm circle

After the flow of concrete has stabilized without disturbing the baseplate or concrete, measure the largest diameter of the flow spread and record as  $d_1$  to the nearest 10 mm. Then measure the diameter of the flow spread at right angles to  $d_1$  to the nearest 10 mm and record as  $d_2$  to the nearest 10 mm. If the difference between  $d_1$  and  $d_2$  is greater than 50 mm another sample shall be taken and the procedure repeated.

If two consecutive tests show the difference between  $d_1$  and  $d_2$  to be greater than 50 mm, the concrete lacks the necessary flowability for the slump-flow test to be suitable.

Check the concrete spread for signs of segregation and report under item 4.6, f) in a qualitative way, e.g. no indication of segregation, strong indication of segregation.

NOTE Signs of segregation include a ring of cement paste/mortar and segregated coarse aggregate in the central area.

Dimensions in millimetres

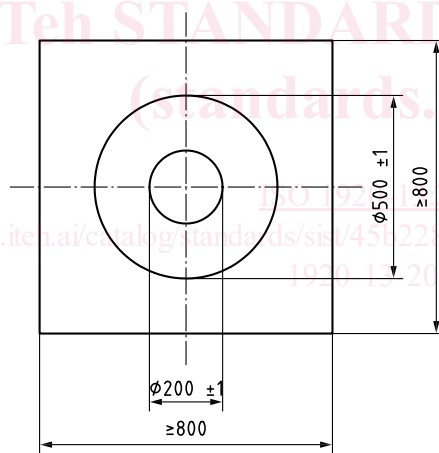

Figure 1 — Baseplate

Dimensions in millimetres

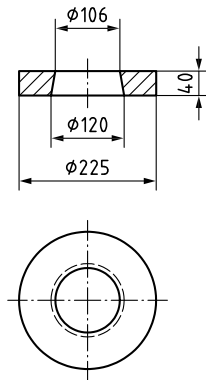

Figure 2 — Example of dimensions of a steelwighted collar

#### 4.6 Test result

The slump-flow,  $SF$ , is the mean of  $d_1$  and  $d_2$ , expressed to the nearest 10 mm, given by Formula (1).

$$SF = \frac{(d_1 + d_2)}{2} \quad (1)$$

where

$SF$  is the slump-flow, in millimetres;

$d_1$  is the largest diameter of flow spread, in millimetres;

$d_2$  is the flow spread at  $90^\circ$  to  $d_1$ , in millimetres. [ISO 1920-13:2018](https://standards.iteh.ai/ISO-1920-13-2018)

The  $t_{500}$  time is reported to the nearest 0,5 s. [g/standards/sist/45b22871-c5a6-4186-9b9c-e6c850d49903/iso-1920-13-2018](https://standards.iteh.ai/ISO-1920-13-2018)

#### 4.7 Test report

The test report shall include:

- the identification of the test sample;
- the location where the test was performed;
- the date and time of test;
- the slump-flow,  $SF$ , to the nearest 5 mm;
- the  $t_{500}$  time, to the nearest 0,1 s (when requested);
- any indication of segregation of the concrete;
- any deviation from the standard test method;
- a declaration by the person technically responsible for the test that it was carried out in accordance with this document, except as noted in g).

The report may include:

- the temperature of the concrete at the time of test;
- the age of concrete at time of test (if known).

#### 4.8 Repeatability and reproducibility

The repeatability,  $r$ , and reproducibility,  $R$ , have been determined by a programme including eight laboratories, 16 operators and two replicates, and interpreted in accordance with ISO 5725-2.

The resulting values for  $r$  and  $R$  are given in Tables 1 and 2.

**Table 1 — Repeatability and reproducibility for typical values of Slump-flow**

Slump-flow, $SF$ mm	<600	600–750	>750
Repeatability, $r$	n/a	42	22
Reproducibility, $R$	n/a	43	28

**Table 2 — Repeatability and reproducibility for typical values of  $t_{500}$  times**

$t_{500}$ time seconds	<3,5	3,5–6,0	>6,0
Repeatability, $r$	0,66	1,18	n/a
Reproducibility, $R$	0,88	1,18	n/a

## 5 V funnel test

### 5.1 General

This test specifies the procedure for determining the V-funnel flow time for self-compacting concrete. The test is not suitable when the maximum size of the aggregate exceeds 25 mm.

### 5.2 Principle

The relative viscosity is indicated by the time the concrete to flow out of the funnel. And the filling ability is assessed by the time the concrete takes, under the action of its own weight, to flow through section variation of mold. A V-shaped funnel is filled with fresh concrete and the time taken for the concrete to flow out of the funnel is measured and recorded as the V-funnel flow time.

### 5.3 Apparatus

**5.3.1 V-funnel**, made to the internal dimensions and tolerances (see Figure 3), fitted with a quick release, watertight hinged or sliding gate at its base and supported by a frame so that the top of the funnel is horizontal with sufficient clearance beneath the gate to place the container underneath.

The V-funnel shall be made from metal not prone to be readily attacked by cement paste or be liable to rusting; the surfaces shall be smooth, and not readily attacked by cement paste or be liable to rusting.

If the funnel is made from other materials, in-use performance test data shall be available which demonstrates long-term equivalence with metal.

The funnels specified in national standards may be used where applicable.

**5.3.2 Container**, to hold the test sample and having a volume not less than 12 l.

**5.3.3 Stop watch**, capable of measuring to 0,1 s.

**5.3.4 Straight edge**, for striking off concrete level with the top of the funnel.

Dimensions in millimetres