

---

---

## Conformance test methods for RFID enabled tyres

*Méthodes d'essai de conformité de pneumatiques RFID*

**iTeh STANDARD PREVIEW**  
**(standards.iteh.ai)**

[ISO 20912:2020](https://standards.iteh.ai/catalog/standards/sist/e60f6c48-fe93-4dcc-8860-4a63b685075e/iso-20912-2020)

<https://standards.iteh.ai/catalog/standards/sist/e60f6c48-fe93-4dcc-8860-4a63b685075e/iso-20912-2020>



## iTeh STANDARD PREVIEW (standards.iteh.ai)

ISO 20912:2020

<https://standards.iteh.ai/catalog/standards/sist/e60f6c48-fe93-4dcc-8860-4a63b685075e/iso-20912-2020>



### **COPYRIGHT PROTECTED DOCUMENT**

© ISO 2020

All rights reserved. Unless otherwise specified, or required in the context of its implementation, no part of this publication may be reproduced or utilized otherwise in any form or by any means, electronic or mechanical, including photocopying, or posting on the internet or an intranet, without prior written permission. Permission can be requested from either ISO at the address below or ISO's member body in the country of the requester.

ISO copyright office  
CP 401 • Ch. de Blandonnet 8  
CH-1214 Vernier, Geneva  
Phone: +41 22 749 01 11  
Fax: +41 22 749 09 47  
Email: [copyright@iso.org](mailto:copyright@iso.org)  
Website: [www.iso.org](http://www.iso.org)

Published in Switzerland

# Contents

	Page
<b>Foreword</b> .....	<b>iv</b>
<b>Introduction</b> .....	<b>v</b>
<b>1 Scope</b> .....	<b>1</b>
<b>2 Normative references</b> .....	<b>1</b>
<b>3 Terms and definitions</b> .....	<b>1</b>
<b>4 Conformance test methods</b> .....	<b>2</b>
4.1 General.....	2
4.2 Open space method.....	2
4.2.1 General.....	2
4.2.2 Testing site.....	2
4.2.3 Testing layout.....	3
4.2.4 Testing equipment.....	5
4.2.5 Testing method.....	5
4.2.6 Conformance assessment.....	6
4.3 Semi-anechoic method tailored to UHF frequencies.....	6
4.3.1 General.....	6
4.3.2 Testing site and layout.....	6
4.3.3 Testing equipment.....	7
4.3.4 RFID enabled tyre measurement.....	7
4.3.5 Testing method.....	8
4.3.6 Conformance assessment.....	9
<b>Annex A (informative) Conformance test report for RFID enabled tyres</b> .....	<b>10</b>
<b>Annex B (informative) Radiated power</b> .. <a href="https://standards.iteh.ai/catalog/standards/sist/e60f6c48-fe93-4dcc-8860-4a63b685075e/iso-20912-2020">ISO 20912:2020</a> .....	<b>11</b>
<b>Bibliography</b> ..... <a href="https://standards.iteh.ai/catalog/standards/sist/e60f6c48-fe93-4dcc-8860-4a63b685075e/iso-20912-2020">https://standards.iteh.ai/catalog/standards/sist/e60f6c48-fe93-4dcc-8860-4a63b685075e/iso-20912-2020</a>	<b>15</b>

## Foreword

ISO (the International Organization for Standardization) is a worldwide federation of national standards bodies (ISO member bodies). The work of preparing International Standards is normally carried out through ISO technical committees. Each member body interested in a subject for which a technical committee has been established has the right to be represented on that committee. International organizations, governmental and non-governmental, in liaison with ISO, also take part in the work. ISO collaborates closely with the International Electrotechnical Commission (IEC) on all matters of electrotechnical standardization.

The procedures used to develop this document and those intended for its further maintenance are described in the ISO/IEC Directives, Part 1. In particular, the different approval criteria needed for the different types of ISO documents should be noted. This document was drafted in accordance with the editorial rules of the ISO/IEC Directives, Part 2 (see [www.iso.org/directives](http://www.iso.org/directives)).

Attention is drawn to the possibility that some of the elements of this document may be the subject of patent rights. ISO shall not be held responsible for identifying any or all such patent rights. Details of any patent rights identified during the development of the document will be in the Introduction and/or on the ISO list of patent declarations received (see [www.iso.org/patents](http://www.iso.org/patents)).

Any trade name used in this document is information given for the convenience of users and does not constitute an endorsement.

For an explanation of the voluntary nature of standards, the meaning of ISO specific terms and expressions related to conformity assessment, as well as information about ISO's adherence to the World Trade Organization (WTO) principles in the Technical Barriers to Trade (TBT) see [www.iso.org/iso/foreword.html](http://www.iso.org/iso/foreword.html).

This document was prepared by Technical Committee ISO/TC 31, *Tyres, rims and valves*.

Any feedback or questions on this document should be directed to the user's national standards body. A complete listing of these bodies can be found at [www.iso.org/members.html](http://www.iso.org/members.html).

## Introduction

This document is using passive RFID tags in the UHF RFID band from 860 to 930 MHz.

This document describes the conformance to ISO 20909 minimum reading distance within a specific radio frequency region.

Indeed, different RFID tag attachment solutions can be considered as per ISO 20911 and the tests reported in this document allow the tyre manufacturer to evaluate whether the selected option is suitable or not to grant the RFID enabled tyre minimum transmission performance level.

During the development of this document, attention was paid on the key parameters influencing the test results. However, others still remain non-specified therefore a testing lab can use those parameters to their discretion to perform the test.

The specifications in this document are not intended to limit any additional verification.

The use cases have been simplified by considering a standalone/unmounted tyre and describing a test set-up that can be used throughout the tyre's lifetime and/or the tyre's supply chain.

When conformity decisions are being done across various stakeholders, objective comparisons can be performed using the results obtained applying this document.

Additional use cases and more precise, detailed and traceable testing methodologies may be added in future revision of this document as RFID technology and its adoption moves forward.

**iTeh STANDARD PREVIEW**  
**(standards.iteh.ai)**

[ISO 20912:2020](https://standards.iteh.ai/catalog/standards/sist/e60f6c48-fe93-4dcc-8860-4a63b685075e/iso-20912-2020)

<https://standards.iteh.ai/catalog/standards/sist/e60f6c48-fe93-4dcc-8860-4a63b685075e/iso-20912-2020>

**iTeh STANDARD PREVIEW**  
**(standards.iteh.ai)**

ISO 20912:2020

<https://standards.iteh.ai/catalog/standards/sist/e60f6c48-fe93-4dcc-8860-4a63b685075e/iso-20912-2020>

# Conformance test methods for RFID enabled tyres

## 1 Scope

This document defines the test methods for validating the conformance of RFID enabled tyres with the minimum reading distance specifications given in ISO 20909.

The two presented methodologies give comparable test results only when the same radio frequency and energy power parameters are used.

Unless otherwise specified, the tests in this document are to be applied exclusively to a standalone RFID enabled tyre.

This document is not intended to set any requirement on mass production quality control, nor on the frequency for testing.

## 2 Normative references

The following documents are referred to in the text in such a way that some or all of their content constitutes requirements of this document. For dated references, only the edition cited applies. For undated references, the latest edition of the referenced document (including any amendments) applies.

ISO 20909, *Radio frequency identification (RFID) tyre tags*

## 3 Terms and definitions

For the purposes of this document, the following terms and definitions apply.

ISO and IEC maintain terminological databases for use in standardization at the following addresses:

- ISO Online browsing platform: available at <https://www.iso.org/obp>
- IEC Electropedia: available at <http://www.electropedia.org/>

### 3.1

#### **standalone tyre**

non-mounted tyre

### 3.2

#### **RFID enabled tyre**

tyre featuring an RFID tag by means of an embedded, patch or sticker solution

### 3.3

#### **measuring distance**

*d*

linear distance between the RFID tag position and the interrogator antenna

### 3.4

#### **received signal strength indicator**

**RSSI**

indicative, non-calibrated value of the received power at the reader input

Note 1 to entry: This is the power backscattered by the tag towards the reader and measured at the reader input. RSSI is sometimes used to determine a tag's distance, as the signal is stronger from a tag that is closer to the reader antenna, however, the reflections and attenuation due to different materials may distort it.

**3.5  
turn-on power**

$P_{in}^{pto}$ , RFID enabled tyre  
minimum input of conducted power that the interrogator must provide to its antenna to activate the RFID enabled tyre which is placed at the *measuring distance* (3.3)

**3.6  
effective isotropic radiated power  
EIRP**

product of the power supplied to the antenna and the maximum antenna gain in one direction relative to an isotropic radiator (absolute or isotropic gain)

$$EIRP = P_T - L_C + G_a$$

where

$P_T$  is the output power of the transmitter (dBm);

$L_C$  is the cable loss (dB);

$G_a$  is the antenna gain (dBi).

Note 1 to entry: EIRP is limited by local regulation.

**3.7  
reads per seconds  
RPS**

indicative, non-calibrated value of the number of valid reads received per second, by an RFID reader, while interrogating an RFID tag for several seconds

**3.8  
interrogator antenna gain**

$G_R$   
unitless gain of interrogator antenna computed from the isotropic gain [ $10^{(dBi/10)}$ ]

iTeh STANDARD PREVIEW  
(standards.iteh.ai)

ISO 20912:2020

<https://standards.iteh.ai/catalog/standards/sist/e60f6c48-fe93-4dcc-8860-4a63b685075e/iso-20912-2020>

## 4 Conformance test methods

### 4.1 General

Two different test methods are described below. Both can be used to validate the conformance to ISO 20909 minimum reading distance requirement. It is up to the tyre manufacturer to choose one method or the other.

### 4.2 Open space method

#### 4.2.1 General

This test method validates whether the RFID enabled tyre can be read at the minimum reading distance and can be performed even by using a hand-held RFID reader. The specified test is performed in an open environment as described in 4.2.2.

#### 4.2.2 Testing site

The testing area shall be an open space with no object, wall or people (except the operator according to the details described below) in proximity of the tyre and reader in the range defined in 4.2.3.2 and 4.2.3.3.



Also, there shall be no ceiling or at least no ceiling closer than those distances defined in [4.2.3.2](#) and [4.2.3.3](#) from the top of the tyre.

The ground and the ceiling shall minimize electromagnetic reflections during the measurement in order to ensure the accuracy of the test result.

- No atmospheric event (such as snow and rain) shall take place at the testing area during the measurement.
- No environmental change shall occur during the measurement.
- There shall be at least a free space of 2-m radius (excluding testing equipment and device under test) around the tyre on the horizontal plane.
- Personnel should be prohibited to be in the proximity of a 2-m radius around the test setup.
- The operator shall remain behind the reader (and not between the reader and the tag).
- In general, the permeability and permittivity of supporting equipment like tyre stand and others should be low to not influence test results.

To prevent any interference, it is recommended to set up a site survey in order to detect any use of radio frequency within the RFID frequency band. This can be done with a spectrum analyser and a UHF antenna to ensure that the radio frequency transmission levels are at least 10 dB smaller than the backscattering signal from the RFID enabled tyre.

#### 4.2.3 Testing layout

**STANDARD PREVIEW**  
(standards.iteh.ai)

##### 4.2.3.1 General

Two testing layouts are defined. It is up to the tyre manufacturer to choose one or the other, depending of the RFID tag implementation/position.

##### 4.2.3.2 Testing layout for the RFID in/on the tyre sidewall

The layout is depicted in [Figure 1](#).

The minimum distance,  $h_1$ , between the tag position and the ground shall be at least at 1,5 m or 5 times of the minimum reading distance defined in ISO 20909, whichever is the lowest.

The tyre shall be put directly on the ground or on a stand in the testing site, unmounted from the rim.

The minimum distance,  $h_2$ , between the tag position and the ceiling shall be at least 1,5 m or 5 times of the minimum reading distance defined in ISO 20909, whichever is the lowest.

The area where the RFID tag is located shall be horizontally aligned with the reader's antenna as per the following description. To locate the RFID tag, the operator monitors the RSSI or RPS. Once the largest RSSI (or RPS) is obtained, the alignment between the tyre and the reader's antenna is adequate.

**NOTE** The largest RSSI can be unreliable for short distance between tag and reader. Instead a local maximum or minimum of the RSSI can indicate an adequate alignment.

The tyre sidewall surface containing the RFID tag shall be directed towards the reader's antenna.

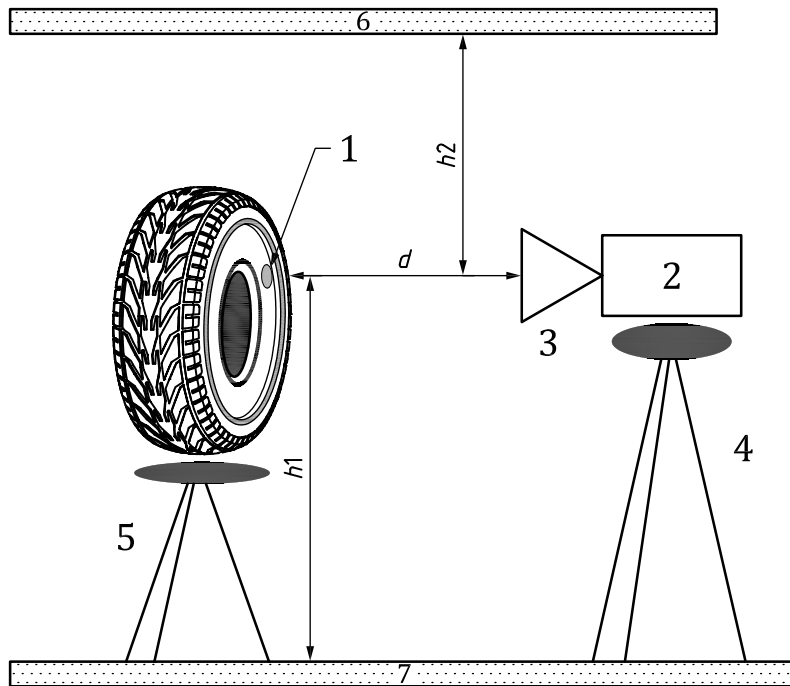

**Key**

- |       |                                                                                                                                                       |   |                  |
|-------|-------------------------------------------------------------------------------------------------------------------------------------------------------|---|------------------|
| $d$   | linear distance between the RFID tag position and the reader's antenna, that is at least 2 times the minimum reading distance as defined in ISO 20909 | 2 | reader           |
| $h_1$ | distance between the tag position and the ground                                                                                                      | 3 | reader's antenna |
| $h_2$ | distance between the tag position and the ceiling                                                                                                     | 4 | reader's stand   |
| 1     | RFID tag location                                                                                                                                     | 5 | tyre stand       |
|       |                                                                                                                                                       | 6 | ceiling          |
|       |                                                                                                                                                       | 7 | ground           |

**Figure 1 — Open space testing layout for the RFID tag in/on the tyre sidewall**

**4.2.3.3 Testing layout for the RFID in/on the tyre tread**

The layout is depicted in [Figure 2](#).

The tyre shall be put directly on the ground or on a stand on testing site, unmounted from the rim.

The minimum distance,  $h_1$ , between the tag position and the ground shall be at least the 1,5 m or 5 times of the minimum reading distance defined in ISO 20909, whichever is the lowest.

In case a tyre stand is required, it shall be made of non-metallic (radio frequency conductive) material to prevent electromagnetic interference.

The minimum distance,  $h_2$ , between the tag position and the ceiling shall be at least 1,5 m or 5 times of the minimum reading distance defined in ISO 20909, whichever is the lowest.

The area where the RFID tag is located shall be horizontally aligned with the reader's antenna as per the following description. To locate the RFID tag, the operator monitors the RSSI or RPS. Once the largest RSSI (or RPS) is obtained, the alignment between the tyre and the reader's antenna is adequate.

**NOTE** The largest RSSI can be unreliable for short distance between tag and reader. Instead a local maximum or minimum of the RSSI can indicate an adequate alignment.

The tyre area surface containing the RFID tag shall be directed towards the reader's antenna.

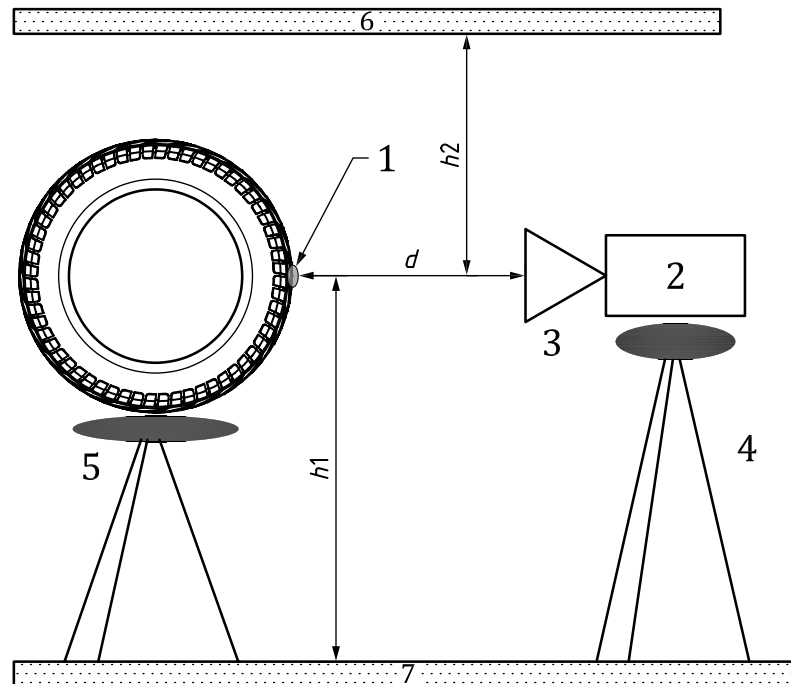
**Key**

$d$	linear distance between the RFID tag position and the reader's antenna, that is at least 2 times the minimum reading distance as defined in ISO 20909	2	reader
$h_1$	distance between the tag position and the ground	3	reader's antenna
$h_2$	distance between the tag position and the ceiling	4	reader's stand
1	RFID tag location	5	tyre stand
		6	ceiling
		7	ground

**Figure 2 — Open space testing layout for the RFID tag in/on the tyre tread**

#### 4.2.4 Testing equipment

An RFID hand-held reader is required that is able to read the RFID tag according to EPC Class1 Gen2 protocol or the RFID protocol of ISO/IEC 18000-63.

If desired, the same equipment as stated in 4.3.3 can be used in place of an RFID hand-held reader.

#### 4.2.5 Testing method

The reader shall be set up in order to radiate a power at frequencies that are within the authorized frequency band.

NOTE 1 Legal requirements can apply to the power.

NOTE 2 Local requirements define the authorized frequency band.

The reader shall send a command or a set of commands in order to read the RFID enabled tyre UII including SGTIN96 successfully without errors.

NOTE As part of the PCWord, the CRC is automatically backscattered once the tag has been inventoried. Therefore "without errors" implies that the verification of the value of the CRC was successful according to the EPC Class1 Gen2 or ISO/IEC 18000-63 protocol.