

---

---

**Thermal insulating products  
for building applications —  
Determination of short-term water  
absorption by partial immersion**

*Produits isolants thermiques destinés aux applications du bâtiment —  
Détermination de l'absorption d'eau à court terme par immersion  
partielle*

**iTeh STANDARD PREVIEW**  
**(standards.iteh.ai)**

ISO 29767:2019

<https://standards.iteh.ai/catalog/standards/sist/649a0289-0927-4e05-950b-1ae6bb4974cb/iso-29767-2019>



## iTeh STANDARD PREVIEW (standards.iteh.ai)

ISO 29767:2019

<https://standards.iteh.ai/catalog/standards/sist/649a0289-0927-4e05-950b-1ae6bb4974cb/iso-29767-2019>



### **COPYRIGHT PROTECTED DOCUMENT**

© ISO 2019

All rights reserved. Unless otherwise specified, or required in the context of its implementation, no part of this publication may be reproduced or utilized otherwise in any form or by any means, electronic or mechanical, including photocopying, or posting on the internet or an intranet, without prior written permission. Permission can be requested from either ISO at the address below or ISO's member body in the country of the requester.

ISO copyright office  
CP 401 • Ch. de Blandonnet 8  
CH-1214 Vernier, Geneva  
Phone: +41 22 749 01 11  
Fax: +41 22 749 09 47  
Email: [copyright@iso.org](mailto:copyright@iso.org)  
Website: [www.iso.org](http://www.iso.org)

Published in Switzerland

# Contents

	Page
Foreword .....	iv
<b>1 Scope</b> .....	<b>1</b>
<b>2 Normative references</b> .....	<b>1</b>
<b>3 Terms and definitions</b> .....	<b>1</b>
<b>4 Principle</b> .....	<b>1</b>
<b>5 Apparatus</b> .....	<b>1</b>
<b>6 Test specimens</b> .....	<b>2</b>
6.1 Dimensions of test specimens .....	2
6.2 Number of test specimens .....	3
6.3 Preparation of test specimens .....	3
6.4 Conditioning of test specimens .....	3
<b>7 Procedure</b> .....	<b>3</b>
7.1 Test conditions .....	3
7.2 Test procedure .....	3
7.2.1 Method A (drainage) .....	3
7.2.2 Method B (deduction of initial water uptake) .....	4
<b>8 Calculation and expression of results</b> .....	<b>4</b>
<b>9 Accuracy of measurement</b> .....	<b>5</b>
<b>10 Test report</b> .....	<b>5</b>
<b>Bibliography</b> .....	<b>7</b>

[ISO 29767:2019](https://standards.iteh.ai/catalog/standards/sist/649a0289-0927-4e05-950b-1ae6bb4974cb/iso-29767-2019)  
<https://standards.iteh.ai/catalog/standards/sist/649a0289-0927-4e05-950b-1ae6bb4974cb/iso-29767-2019>

## Foreword

ISO (the International Organization for Standardization) is a worldwide federation of national standards bodies (ISO member bodies). The work of preparing International Standards is normally carried out through ISO technical committees. Each member body interested in a subject for which a technical committee has been established has the right to be represented on that committee. International organizations, governmental and non-governmental, in liaison with ISO, also take part in the work. ISO collaborates closely with the International Electrotechnical Commission (IEC) on all matters of electrotechnical standardization.

The procedures used to develop this document and those intended for its further maintenance are described in the ISO/IEC Directives, Part 1. In particular the different approval criteria needed for the different types of ISO documents should be noted. This document was drafted in accordance with the editorial rules of the ISO/IEC Directives, Part 2 (see [www.iso.org/directives](http://www.iso.org/directives)).

Attention is drawn to the possibility that some of the elements of this document may be the subject of patent rights. ISO shall not be held responsible for identifying any or all such patent rights. Details of any patent rights identified during the development of the document will be in the Introduction and/or on the ISO list of patent declarations received (see [www.iso.org/patents](http://www.iso.org/patents)).

Any trade name used in this document is information given for the convenience of users and does not constitute an endorsement.

For an explanation on the voluntary nature of standards, the meaning of ISO specific terms and expressions related to conformity assessment, as well as information about ISO's adherence to the World Trade Organization (WTO) principles in the Technical Barriers to Trade (TBT) see: [www.iso.org/iso/foreword.html](http://www.iso.org/iso/foreword.html).

This document was prepared by the European Committee for Standardization (CEN) Technical Committee CEN/TC 88, *Thermal insulating materials and products*, in collaboration with ISO Technical Committee TC 163, *Thermal performance and energy use in the built environment*, Subcommittee SC 1, *Test and measurement methods*, in accordance with the agreement on technical cooperation between ISO and CEN (Vienna Agreement).

This second edition cancels and replaces the first edition (ISO 29767:2008), which has been technically revised. It also incorporates the Amendment ISO 29767:2008/Amd.1:2014. The main changes compared to the previous edition are as follows:

- The content in [5.3](#), [6.4](#), [7.1](#) and Clause [10](#) has been revised to reflect the conditions for tropical countries.

Any feedback or questions on this document should be directed to the user's national standards body. A complete listing of these bodies can be found at [www.iso.org/members.html](http://www.iso.org/members.html).

# Thermal insulating products for building applications — Determination of short-term water absorption by partial immersion

## 1 Scope

This document specifies the equipment and procedures for determining the short-term water absorption of specimens by partial immersion. It is applicable to thermal insulating products.

NOTE It is intended to simulate the water absorption caused by a 24 h raining period during construction work.

## 2 Normative references

The following documents are referred to in the text in such a way that some or all of their content constitutes requirements of this document. For dated references, only the edition cited applies. For undated references, the latest edition of the referenced document (including any amendments) applies.

ISO 29768, *Thermal insulating products for building applications — Determination of linear dimensions of test specimens*

## 3 Terms and definitions

No terms and definitions are listed in this document.

ISO and IEC maintain terminological databases for use in standardization at the following addresses:

- IEC Electropedia: available at <http://www.electropedia.org/>
- ISO Online browsing platform: available at <https://www.iso.org/obp>

## 4 Principle

A test specimen is placed with its lower part in water, for a period of 24 h, and its change in mass is measured.

The excess water adhering to the surface but not absorbed by the test specimen is removed by drainage (method A) or taken into account by deduction of the initial water uptake (method B).

## 5 Apparatus

**5.1 Balance**, capable of determining the mass of a specimen to an accuracy of 0,1 g.

**5.2 Water tank**, with a device for keeping the water level constant to within  $\pm 2$  mm, and a device to keep the test specimen in position. The device to keep the test specimen in position shall not cover more

than 15 % of the cross-sectional area of the test specimen, which is exposed to water. An example is shown in [Figure 1](#).

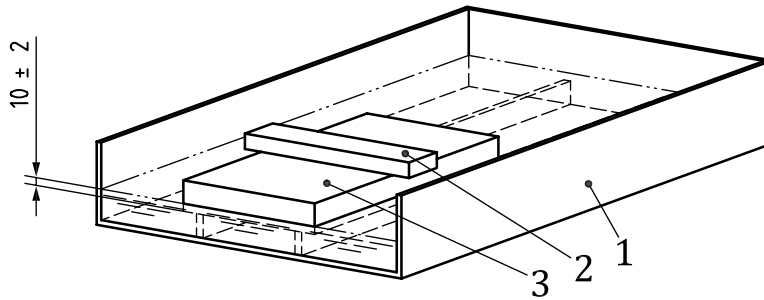

**Key**

- 1 water tank
- 2 load to keep the specimen in position
- 3 test specimen

**Figure 1 — Examples of partial immersion test device**

**5.3 Tap water**, adjusted to a temperature of  $(23 \pm 5) ^\circ\text{C}$ . In case of dispute, deionised water shall be used.

In tropical countries, different conditions and testing conditions can be relevant. In such cases the temperature shall be  $(27 \pm 5) ^\circ\text{C}$ , and this shall be stated in the test report.

**5.4 Equipment for drainage** (examples are shown in [Figures 2 a\)](#) and [2 b\)](#)).

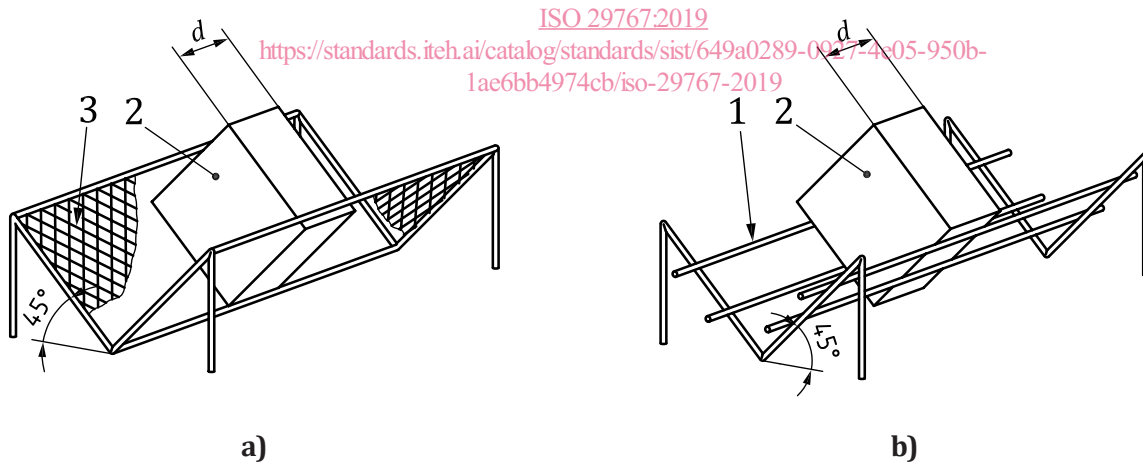

**Key**

- 1 stainless steel mesh
- 2 test specimen
- 3 perforated stainless steel

**Figure 2 — Examples of suitable equipment for drainage**

**6 Test specimens**

**6.1 Dimensions of test specimens**

The thickness of test specimens shall be equal to the original product thickness.

The specimens shall be prisms of square cross section having a side length of  $(200 \pm 1)$  mm.

## 6.2 Number of test specimens

The number of test specimens shall be as specified in the relevant product standard. If the number is not specified, then at least four test specimens shall be used.

In the absence of a product standard or any other technical specification, the number of specimens can be agreed between parties.

## 6.3 Preparation of test specimens

The test specimens shall be cut so that they do not include product edges.

The test specimens shall be prepared by methods that do not change the original structure of the product. Any skins, facings and/or coatings shall be retained.

NOTE Special methods of preparation, when needed, are given in the relevant product standard or any other technical specification.

## 6.4 Conditioning of test specimens

The test specimens shall be conditioned for at least 6 h at  $(23 \pm 5)$  °C. In case of dispute, they shall be conditioned at  $(23 \pm 2)$  °C and  $(50 \pm 5)$  % relative humidity for the time stated in the relevant product standard.

In tropical countries different conditioning conditions might be relevant. In this cases the conditions shall be at  $(23 \pm 2)$  °C and  $(65 \pm 5)$  % and be stated clearly in the test report.

## 7 Procedure <https://standards.iteh.ai/catalog/standards/sist/649a0289-0927-4e05-950b-1ae6bb4974cb/iso-29767-2019>

### 7.1 Test conditions

Testing shall be carried out at  $(23 \pm 5)$  °C. In case of dispute, it shall be carried out at  $(23 \pm 2)$  °C and  $(50 \pm 5)$  % RH.

In tropical countries different conditioning and testing conditions might be relevant. In this cases the conditions shall be 27° C/ 65 % RH and be stated clearly in the test report.

### 7.2 Test procedure

The choice of the method (A or B) shall be as specified in the relevant product standard.

In the absence of a product standard or any other International or European technical specification, the method can be agreed between parties.

The dimensions of the test specimens shall be measured in accordance with ISO 29768.

#### 7.2.1 Method A (drainage)

Weigh the test specimen to the nearest 0,1 g to determine its initial mass,  $m_0$ .

The test shall be carried out with half the number of specimens with one larger face up and the other half with the same face down.

Place the test specimen in the empty water tank and apply a sufficient load to keep it partially immersed when water is added. Carefully add the water to the tank until the bottom face of the test specimen is  $(10 \pm 2)$  mm below the surface of the water (see example in [Figure 1](#)). Ensure that the water level remains constant during the test.

After 24 h ± 30 min remove the test specimen: drain it for (10 ± 0,5) min by placing it vertically on a mesh, inclined at 45° as shown in [Figure 2 a\)](#) or [2 b\)](#). Then weigh the test specimen to determine its mass,  $m_{24}$ .

**7.2.2 Method B (deduction of initial water uptake)**

Weigh the test specimen to an accuracy of 0,1 g to determine its initial mass,  $m_0$ .

Testing shall be carried out with half the number of specimens with one larger face up and the other half with the same face down.

Place the test specimen in the water tank in such position that it is partially immersed in water with its bottom face (10 ± 2) mm below the water level. Remove the test specimen after 10 s holding it horizontally and place it, within 5 s, in a plastic tray of known mass. Weigh this tray with the specimen to determine the test specimen mass including the initial water uptake,  $m_1$ .

Replace the test specimen in the water tank and apply a sufficient load to keep the test specimen partially immersed in water with its bottom face (10 ± 2) mm below the water level (see example in [Figure 1](#)). Ensure that the water level remains constant during the test.

After 24 h ± 30 min remove the test specimen, holding it horizontally, and place it, within 5 s, in the plastic tray of known mass to determine its mass,  $m_{24}$ .

Method B is only applicable if the initial water uptake is less than or equal to 0,5 kg/m<sup>2</sup>, where this is calculated using [Formula \(1\)](#).

**iTeh STANDARD PREVIEW**  
(standards.iteh.ai)

$$\frac{m_1 - m_0}{A_p} \tag{1}$$

where

[ISO 29767:2019](https://standards.iteh.ai/catalog/standards/sist/649a0289-0927-4e05-950b-)  
<https://standards.iteh.ai/catalog/standards/sist/649a0289-0927-4e05-950b->

$m_1$  is the mass of the test specimen including the initial water uptake (method B), in kilograms (kg);

$m_0$  is the initial mass of the test specimen, in kilograms (kg);

$A_p$  is the bottom surface area of the test specimen, in square metres (m<sup>2</sup>).

**8 Calculation and expression of results**

The test result shall be the mean value of the individual values. For products having dissimilar faces, two mean values shall be calculated.

NOTE Results should not be extrapolated to other thicknesses.

Calculate the short-term water absorption by partial immersion,  $W_p$ , in kilograms per square metre, using [Formulae \(2\)](#) and [\(3\)](#).

**Method A**

$$W_p = \frac{m_{24} - m_0}{A_p} \tag{2}$$

**Method B**

$$W_p = \frac{m_{24} - m_1}{A_p} \tag{3}$$



where

- $m_0$  is the initial mass of the test specimen as determined in method A, in kilograms (kg);
- $m_1$  is the mass of the test specimen including the initial water uptake in method B, in kilograms (kg);
- $m_{24}$  is the mass of the test specimen after partial immersion for 24 h (method A and B), in kilograms (kg);
- $A_p$  is the bottom surface area of the test specimen, in square metres (m<sup>2</sup>).
- $W_p$  shall be given to the nearest 0,01 kg/m<sup>2</sup>.

## 9 Accuracy of measurement

An interlaboratory test was performed with 6 to 10 laboratories and three products were tested regarding test method A.

For method B, 6 laboratories performed the test on one product.

The results were analysed according to ISO 5725-2.

The results from the test are given in [Table 1](#):

**Table 1 — Short-term partial immersion**  
(standards.iteh.ai)

Test conditions	Water uptake (in kg/m <sup>2</sup> )		
	Range measured $W_p$	Estimate of reproducibility variance $S_R$	95 % reproducibility limit
Method A (drainage)	0,02 to 0,50	0,03	0,10
Method B (deduction of initial water uptake)	0,04 to 0,20	0,05	0,15

NOTE These terms are applied as described in ISO 5725-2.

Repeatability has not been determined.

Bias cannot be determined in this test method as there is not any accepted reference material for it.

NOTE The choice of products were selected to get a wide range of water uptake.

## 10 Test report

The test report shall include the following information:

- a) a reference to this document;
- b) product identification;
  - 1) product name, factory, manufacturer, or supplier;
  - 2) production code number;
  - 3) type of product;
  - 4) packaging;
  - 5) the form in which the product arrived at the laboratory;