

---

---

**Prefilled syringes —**

Part 6:

**Plastic barrels for injectables and  
sterilized subassembled syringes  
ready for filling**

*Seringues préremplies —*

*(https://standards.iteh.ai/catalog/standards/iso/7684407b-ef1e-45f6-8e07-b207bf55a0ee/iso-11040-6-2019)*  
*Partie 6: Cylindres en plastique pour produits injectables et seringues  
pré-assemblées stérilisées préremplissables*

**Document Preview**

ISO 11040-6:2019

<https://standards.iteh.ai/catalog/standards/iso/7684407b-ef1e-45f6-8e07-b207bf55a0ee/iso-11040-6-2019>



iTeh Standards  
(<https://standards.iteh.ai>)  
Document Preview

ISO 11040-6:2019

<https://standards.iteh.ai/catalog/standards/iso/7684407b-ef1e-45f6-8e07-b207bf55a0ee/iso-11040-6-2019>



**COPYRIGHT PROTECTED DOCUMENT**

© ISO 2019

All rights reserved. Unless otherwise specified, or required in the context of its implementation, no part of this publication may be reproduced or utilized otherwise in any form or by any means, electronic or mechanical, including photocopying, or posting on the internet or an intranet, without prior written permission. Permission can be requested from either ISO at the address below or ISO's member body in the country of the requester.

ISO copyright office  
CP 401 • Ch. de Blandonnet 8  
CH-1214 Vernier, Geneva  
Phone: +41 22 749 01 11  
Fax: +41 22 749 09 47  
Email: [copyright@iso.org](mailto:copyright@iso.org)  
Website: [www.iso.org](http://www.iso.org)

Published in Switzerland

# Contents

Page

|                                                                                                            |           |
|------------------------------------------------------------------------------------------------------------|-----------|
| <b>Foreword</b> .....                                                                                      | <b>iv</b> |
| <b>Introduction</b> .....                                                                                  | <b>v</b>  |
| <b>1 Scope</b> .....                                                                                       | <b>1</b>  |
| <b>2 Normative references</b> .....                                                                        | <b>1</b>  |
| <b>3 Terms and definitions</b> .....                                                                       | <b>2</b>  |
| <b>4 General requirements</b> .....                                                                        | <b>3</b>  |
| 4.1 Quality systems.....                                                                                   | 3         |
| 4.2 Testing.....                                                                                           | 3         |
| 4.3 Documentation.....                                                                                     | 3         |
| <b>5 Dimensions and designation</b> .....                                                                  | <b>4</b>  |
| 5.1 Design including dimensions.....                                                                       | 4         |
| 5.2 Design requirements.....                                                                               | 7         |
| 5.2.1 Head design.....                                                                                     | 7         |
| 5.2.2 Dead space.....                                                                                      | 7         |
| 5.2.3 Functional testing of Luer cone/Luer lock connection.....                                            | 7         |
| 5.2.4 Flange breakage resistance.....                                                                      | 7         |
| 5.2.5 Syringe tip breakage resistance.....                                                                 | 7         |
| <b>6 Requirements</b> .....                                                                                | <b>7</b>  |
| 6.1 General.....                                                                                           | 7         |
| 6.2 Material.....                                                                                          | 8         |
| 6.2.1 General.....                                                                                         | 8         |
| 6.2.2 Duty of notification concerning modifications to polymers.....                                       | 8         |
| 6.2.3 Needle.....                                                                                          | 8         |
| 6.2.4 Closure system.....                                                                                  | 9         |
| 6.2.5 Closure system integrity.....                                                                        | 10        |
| 6.3 Physical requirements.....                                                                             | 10        |
| 6.3.1 Sterilization.....                                                                                   | 10        |
| 6.3.2 Clarity and transparency.....                                                                        | 10        |
| 6.3.3 Particulate contamination.....                                                                       | 10        |
| 6.3.4 Lubricants.....                                                                                      | 11        |
| 6.4 Chemical requirements.....                                                                             | 11        |
| 6.5 Endotoxins and biological requirements.....                                                            | 11        |
| <b>7 Graduation</b> .....                                                                                  | <b>12</b> |
| <b>8 Packaging and labelling</b> .....                                                                     | <b>12</b> |
| <b>Annex A (informative) Examples of types of sterilized subassembled syringes ready for filling</b> ..... | <b>13</b> |
| <b>Annex B (informative) Head designs</b> .....                                                            | <b>16</b> |
| <b>Annex C (normative) Test methods for syringe barrels</b> .....                                          | <b>18</b> |
| <b>Annex D (informative) Sample preparation for endotoxin and particulate determination</b> .....          | <b>24</b> |
| <b>Annex E (informative) Evaluation of syringe lubrication by glide force test method</b> .....            | <b>28</b> |
| <b>Annex F (informative) Needle penetration test</b> .....                                                 | <b>31</b> |
| <b>Annex G (normative) Test methods for syringe closure systems</b> .....                                  | <b>34</b> |
| <b>Annex H (informative) Dye solution tightness test</b> .....                                             | <b>49</b> |
| <b>Annex I (informative) Guidance on materials</b> .....                                                   | <b>51</b> |
| <b>Bibliography</b> .....                                                                                  | <b>52</b> |

## Foreword

ISO (the International Organization for Standardization) is a worldwide federation of national standards bodies (ISO member bodies). The work of preparing International Standards is normally carried out through ISO technical committees. Each member body interested in a subject for which a technical committee has been established has the right to be represented on that committee. International organizations, governmental and non-governmental, in liaison with ISO, also take part in the work. ISO collaborates closely with the International Electrotechnical Commission (IEC) on all matters of electrotechnical standardization.

The procedures used to develop this document and those intended for its further maintenance are described in the ISO/IEC Directives, Part 1. In particular, the different approval criteria needed for the different types of ISO documents should be noted. This document was drafted in accordance with the editorial rules of the ISO/IEC Directives, Part 2 (see [www.iso.org/directives](http://www.iso.org/directives)).

Attention is drawn to the possibility that some of the elements of this document may be the subject of patent rights. ISO shall not be held responsible for identifying any or all such patent rights. Details of any patent rights identified during the development of the document will be in the Introduction and/or on the ISO list of patent declarations received (see [www.iso.org/patents](http://www.iso.org/patents)).

Any trade name used in this document is information given for the convenience of users and does not constitute an endorsement.

For an explanation of the voluntary nature of standards, the meaning of ISO specific terms and expressions related to conformity assessment, as well as information about ISO's adherence to the World Trade Organization (WTO) principles in the Technical Barriers to Trade (TBT) see [www.iso.org/iso/foreword.html](http://www.iso.org/iso/foreword.html).

This document was prepared by Technical Committee ISO/TC 76 *Transfusion, infusion and injection, and blood processing equipment for medical and pharmaceutical use*.

This second edition cancels and replaces the first edition (ISO 11040-6:2012), which has been technically revised. The main changes compared to the previous edition are as follows:

- Scope has been extended by adding sterilized subassembled syringes ready for filling. Appropriate requirements and test methods have been included;
- general requirements have been added on quality systems, testing, and documentation;
- requirements on labelling have been revised;
- requirements on packaging have been added;
- requirements on syringes barrels have been revised by:
  - adding requirements and related test methods for flange breakage and tip breakage (cone or staked in needle head) resistance, and
  - adding requirements on lubrication.

A list of all parts in the ISO 11040 series can be found on the ISO website.

Any feedback or questions on this document should be directed to the user's national standards body. A complete listing of these bodies can be found at [www.iso.org/members.html](http://www.iso.org/members.html).

## Introduction

Ampoules and injection bottles have been mainly used as primary packaging material for the administration of injectables. However, for the injection of the liquid medicinal products stored in these containers, a hypodermic syringe combined with the appropriate injection cannula is also needed. This requires that the medicinal product be transferred into the hypodermic syringe before its final use. This procedure is not only time-consuming; it can also easily result in mix-ups and possible contamination.

In conjunction with the appropriate sealing components, prefilled single-use syringes conforming to this document form a safe system for the transport, storage and administration of medicine. Due to relatively simple handling procedures, they permit fast injection of the medicinal products contained within them.

Such prefilled syringes permit immediate injection of the product contained after relatively simple handling. These syringes can also be used in injectors with automated functions where further and particular requirements apply.

In more recent years, new technological developments have been made to provide prefilled syringes on the basis of polymers as a material for the barrel of a prefilled syringe system; these developments have been spurred by progress in polymer science and introduction of novel polymers.

This document can also be used by engineers as a basis for the development and marketing of standardized filling and processing equipment, e.g. so-called tub and nest filling presentations. Manufacturers of filling equipment and ancillary processing equipment can use this document to achieve a certain degree of unification with regard to the design of these standardized items of equipment.

Based on the dimensions of the prefilled syringes, appropriate components, such as rubber plungers, tip caps, needle shields, and other closure systems can also be standardized. In conjunction with the right sealing components, they offer a system for (parenteral) injectable use. It is advised to contact the component and system provider for verifying the component compatibility, e.g. for silicone-oil free or lubricant free systems or if specific matching of components is required. The producers of filling machines can apply this document to achieve a degree of standardization in the equipment of the machines.

For sterilized sub-assembled syringes ready for filling, the responsibility for the process steps relevant to the injectable product lies with the manufacturer<sup>1)</sup>. Following the assembly of the needle shield on syringes with a staked needle or tip caps for the Luer cone version, the subassembled syringes are placed into nests. The nests, in turn, are placed into a plastic tub. The syringes in the nest are protected by means of an insert liner and the tub itself is sealed by a sealing lid (which is currently and, so far, primarily achieved using a porous material). Thus, the tub properly sealed with the sealing lid represents the “sterile barrier system”. The sealed tub is then wrapped into a sealable bag and, thus, ready for sterilization. Various sterilization methods can be applied with polymer syringes e.g. Gamma, E-beam, X-Ray irradiation, Moist Heat (autoclave), ethylene oxide.

The sterilized subassembled syringes ready for filling are delivered to the pharmaceutical companies in a sterile condition, where they are processed on suitable machines.

Compatibility tests with the intended drug product are carried out under the responsibility of the market authorization holder before the final approval is granted. This is described in 11040-8.

**NOTE** Primary packaging materials are an integral part of medicinal products. Thus, the principles of the current Good Manufacturing Practices (cGMP) apply to the manufacturing of these components (e.g. ISO 15378).

---

1) Washing after injection moulding for endotoxin reduction can be eliminated provided that the moulding, assembling and packaging steps into the sealed sterile barrier system (tub and nest) takes place in a monitored cleanroom (ISO 14644) and accompanied by microbial cleanroom monitoring.



# Prefilled syringes —

## Part 6:

# Plastic barrels for injectables and sterilized subassembled syringes ready for filling

## 1 Scope

This document specifies materials, dimensions, quality, and performance requirements, as well as test methods for polymer barrels and sterilized subassembled syringes ready for filling, intended for single use only.

This document also specifies those components that are part of the sterilized subassembled syringe ready for filling.

Polymer barrels and sterilized subassembled syringes ready for filling in accordance with this document are intended for single use only.

Components to complete the subassembled syringe, such as plunger and rod, are not specified in this document.

Prefilled syringes can be produced on dedicated and specifically designed processing equipment such as inline moulding and filling. This document does not apply but can be used also for such dedicated prefilled syringes.

## 2 Normative references

The following documents are referred to in the text in such a way that some or all of their content constitutes requirements of this document. For dated references, only the edition cited applies. For undated references, the latest edition of the referenced document (including any amendments) applies.

ISO 7864:2016, *Sterile hypodermic needles for single use — Requirements and test methods*

ISO 7886-1, *Sterile hypodermic syringes for single use — Part 1: Syringes for manual use*

ISO 8871-1, *Elastomeric parts for parenterals and for devices for pharmaceutical use — Part 1: Extractables in aqueous autoclavates*

ISO 9626, *Stainless steel needle tubing for the manufacture of medical devices — Requirements and test methods*

ISO 10993-1, *Biological evaluation of medical devices — Part 1: Evaluation and testing within a risk management process*

ISO 14971, *Medical devices — Application of risk management to medical devices*

ISO 80369-1, *Small-bore connectors for liquids and gases in healthcare applications — Part 1: General requirements*

ISO 80369-7, *Small-bore connectors for liquids and gases in healthcare applications — Part 7: Connectors for intravascular or hypodermic applications*

### 3 Terms and definitions

For the purposes of this document, the following terms and definitions apply.

ISO and IEC maintain terminological databases for use in standardization at the following addresses:

- ISO Online browsing platform: available at <https://www.iso.org/obp>
- IEC Electropedia: available at <http://www.electropedia.org/>

#### 3.1

##### **customer**

business entity which purchases *syringe barrels* (3.6) or *sterilized subassembled syringes ready for filling* (3.7) and conducts further processing or filling as appropriate

#### 3.2

##### **manufacturer**

business entity which performs or is otherwise responsible for the manufacturing of the *syringe barrels* (3.6) (plastic barrels for injectables) or for the *sterilized subassembled syringes ready for filling* (3.7) by the *customer* (3.1)

#### 3.3

##### **needle shield**

syringe closure used with staked needle subassembled syringes that is designed to protect the needle point/bevel from damage, to allow sterilization of the needle, and to maintain sterility of the contents of the syringe and of the needle up to the time of injection

#### 3.4

##### **prefilled syringe**

container system filled with the injectable product ready for injection

Note 1 to entry: Components of prefilled syringes are barrel, needle, closure system, plunger, and rod. Examples of sterilized subassembled syringes ready for filling including components are given in [Annex A](#).

#### 3.5

##### **staked needle syringe**

syringe with a needle integrated into the barrel

Note 1 to entry: The fixation can be done by insert moulding, gluing or other bonding methods.

#### 3.6

##### **syringe barrel**

cylindrical polymer body with front end and finger flange

Note 1 to entry: See [Figure 1](#).

Note 2 to entry: The syringe barrel can be equipped with a staked needle.

#### 3.7

##### **sterilized subassembled syringe ready for filling**

subassembly that has been pre-treated, consisting of a *syringe barrel* (3.6) and a closure system

Note 1 to entry: The subassembly has been pre-treated by applying the following processes, as applicable:

- injection moulding;
- assembling/lubricating needle;
- applying a lubricant to syringe barrel inner surface;
- sealing the syringe with a closure system;
- packaging (see ISO 11040-7);



— sterilization.

Note 2 to entry: Examples of sterilized subassembled syringes ready for filling including components are given in [Annex A](#).

### 3.8

#### syringe closure system

component or multi-component system designed to close the syringe system at the front end that is designed to allow sterilization of the syringe tip and maintain sterility of the contents of the syringe up to the time of injection

EXAMPLE Tip cap, *needle shield* ([3.3](#)), tamper-evident closure system.

## 4 General requirements

### 4.1 Quality systems

The activities described within this document shall be carried out within a formal quality system.

NOTE 1 ISO 15378 contains requirements for a suitable quality management system for primary packaging materials for medicinal products.

NOTE 2 ISO 14971 can be used as a tool for conducting risk assessment.

NOTE 3 ISO 13485 can be used as a tool for design control during development phase and contains requirements for a suitable quality management system.

### 4.2 Testing

4.2.1 Any suitable test system can be used when the required accuracy (calibration) and precision (gauge repeatability and reproducibility) can be obtained. The gauge repeatability and reproducibility of the test apparatus shall be no greater than 20 % of the allowed tolerance range for any given measurement. For destructive test measurements, the gauge repeatability and reproducibility shall be no greater than 30 % of the allowed tolerance range. At a minimum, the gauge repeatability and reproducibility should cover  $\pm 2$  standard deviations (thereby covering approximately 95 % of the variation).

EXAMPLE A measurement system with a measurement specification limit of  $\pm 0,01$  ml (range of 0,02 ml) comes out of the gauge repeatability and reproducibility with a gauge repeatability and reproducibility/tolerance range ratio of 20 %, which means that the gauge repeatability and reproducibility (four standard uncertainties) equals  $0,02 \text{ ml}/5 = 0,004$  ml. The uncertainty of the measurement is  $\pm 2$  standard deviations (see ISO/IEC Guide 98-3), which equals to 0,002 ml.

4.2.2 The sampling plans used for the selection and testing of sterilized subassembled syringes ready for filling or components thereof shall be based upon statistically valid rationale.

NOTE Examples of suitable sampling plans are given in ISO 2859-1 and ISO 3951 (all parts).

4.2.3 Unless agreed otherwise, testing shall be performed at ambient laboratory conditions.

### 4.3 Documentation

4.3.1 Demonstration of conformity with the requirements of this document shall be documented.

4.3.2 All documentation shall be retained for a specified period of time. The retention period shall consider factors such as regulatory requirements, expiration date, and traceability.

4.3.3 Documentation of conformity with the requirements can include, but is not limited to, performance data, specifications, and test results from validated test methods.

4.3.4 Electronic records, electronic signatures, and handwritten signatures executed to electronic records that contribute to validation, process control, or other quality decision-making processes shall be reliable.

## 5 Dimensions and designation

### 5.1 Design including dimensions

5.1.1 The dimensions of the syringe barrel shall be as shown in [Figure 1](#) and as given in [Table 1](#).

The type of head design shall be agreed upon between the manufacturer and the customer. For the Luer tip and the Luer lock design, ISO 80369-1 shall apply, and ISO 80369-7 apply.

5.1.2 If printing of the barrel is required, it shall be agreed between the manufacturer and the customer.

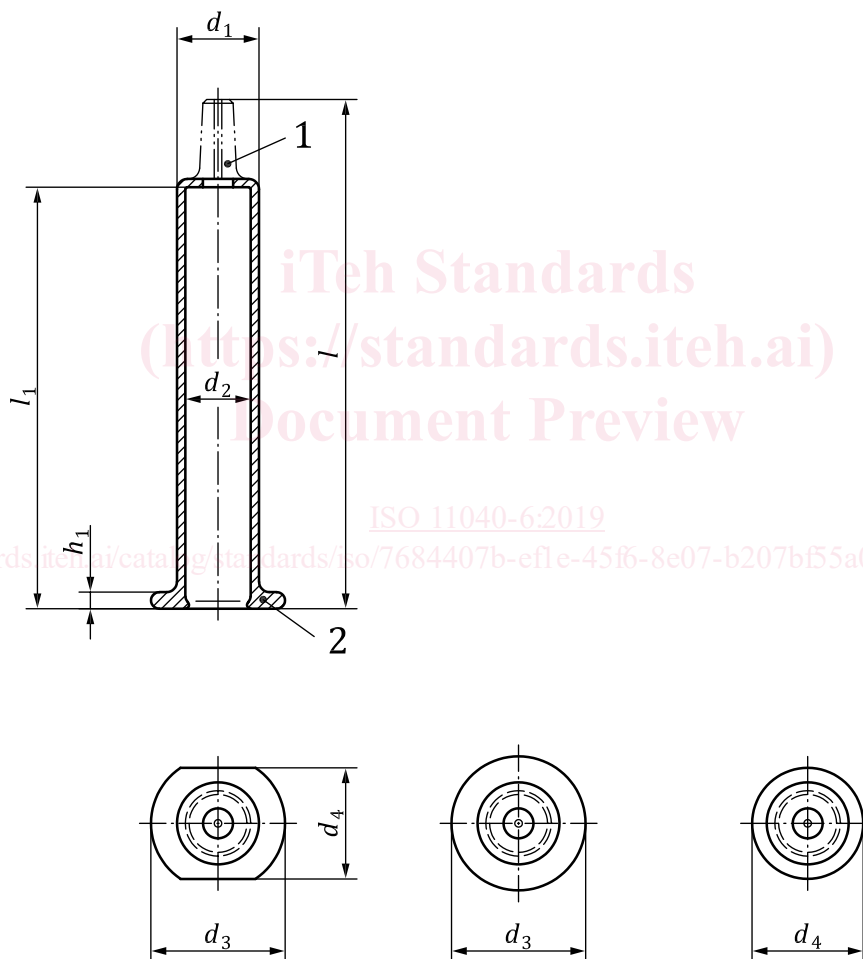

**Key**

- 1 front end
- 2 back end

NOTE 1 Edges can be slightly rounded.

NOTE 2 The design of the finger flange is agreed between the manufacturer and the customer.

**Figure 1 — Typical example of a barrel and polymer finger flange for a prefilled syringe**

The dimensions of the barrel shall be in accordance with [Figure 1](#) and [Table 1](#). These are the minimum required dimensions. Depending on the application, any other dimensions should be agreed between the manufacturer and the customer. Head designs of polymer barrels are shown in [Annex B](#).

When there are particular dimensional requirements, which are common when a syringe is used in combination with injectors, it is recommended that these requirements be agreed between the supplier and the customer.

iTeh Standards  
(<https://standards.iteh.ai>)  
Document Preview

[ISO 11040-6:2019](#)

<https://standards.iteh.ai/catalog/standards/iso/7684407b-ef1e-45f6-8e07-b207bf55a0ee/iso-11040-6-2019>

Table 1 — Barrel dimensions

Dimensions in millimetres

| Nominal volume<br>ml | Nominal dimension tolerances                      |                     |                                      |                                   |                   |                      |                      |  |  |  |
|----------------------|---------------------------------------------------|---------------------|--------------------------------------|-----------------------------------|-------------------|----------------------|----------------------|--|--|--|
|                      | $d_1$                                             | $d_2^a$             | $l$                                  | $l_1$                             | $h_1$             | $d_3$                | $d_4$                |  |  |  |
| 0,5                  | 6,8 to 8,2 ± 0,1<br>6,8 to 9,7 ± 0,1 <sup>b</sup> | 4,6 to 4,8 ± 0,1    | 57,0 to 64,8 ± 0,2                   | 47,5 to 54,1 ± 0,2                | 1,8 to 2,1 ± 0,1  | 13,4 to 13,8 ± 0,1   | 10,5 to 11,0 ± 0,1   |  |  |  |
| 1 <sup>c</sup>       | 8,1 to 9,7 ± 0,1                                  | 6,3 to 6,5 ± 0,1    | 64,0 to 64,5 ± 0,2                   | 54,0 to 54,5 ± 0,2                | 1,9 to 2,3 ± 0,1  | 13,7 to 13,8 ± 0,1   | 10,5 to 11,0 ± 0,1   |  |  |  |
| 1 <sup>d</sup>       | 10,8 to 11,4 ± 0,1                                | 8,5 to 8,75 ± 0,1   | 45,9 to 46,9 ± 0,2                   | 35,2 to 35,9 ± 0,2                | 1,9 to 2,3 ± 0,1  | 17,75 ± 0,1          | 14,70 ± 0,1          |  |  |  |
| 2,25                 | 10,8 to 11,4 ± 0,1                                | 8,5 to 8,75 ± 0,1   | 64,4 to 66,8 ± 0,2                   | 53,9 to 54,6 ± 0,2                | 1,9 to 2,3 ± 0,1  | 17,75 ± 0,1          | 14,70 ± 0,1          |  |  |  |
| 3                    | 10,8 to 11,6 ± 0,1                                | 8,5 to 8,75 ± 0,1   | 82,4 to 84,6 ± 0,2                   | 71,7 to 72,4 ± 0,2                | 1,9 to 2,3 ± 0,1  | 17,75 ± 0,1          | 14,70 ± 0,1          |  |  |  |
| 5                    | 14,4 to 15,0 ± 0,1                                | 11,7 to 12,2 ± 0,1  | 76,5 to 80,0 ± 0,2                   | 64,3 to 66,7 ± 0,2                | 2,0 to 3,1 ± 0,15 | 22,9 to 23,1 ± 0,1   | 19,40 to 19,9 ± 0,1  |  |  |  |
| 10                   | 16,6 to 18,0 ± 0,1                                | 14,1 to 14,7 ± 0,1  | 97,7 to 100,5 ± 0,3                  | 86,2 to 87,3 ± 0,2                | 2,0 to 3,1 ± 0,15 | 26,9 to 27,4 ± 0,1   | 21,50 to 21,9 ± 0,1  |  |  |  |
| 20                   | 21,2 to 22,7 ± 0,15                               | 18,2 to 19,1 ± 0,15 | 107,3 to 120,2 ± 0,3                 | 95,6 to 109,1 ± 0,2               | 2,0 to 3,1 ± 0,15 | 32,25 to 39,0 ± 0,15 | 25,15 to 26,1 ± 0,15 |  |  |  |
| 50                   | 29,2 to 32,3 ± 0,2                                | 26,4 to 29,3 ± 0,2  | 128,8 to<br>151,2 <sup>e</sup> ± 0,5 | 118,7 to 128,2 <sup>e</sup> ± 0,5 | 2,0 to 3,5 ± 0,2  | 45,00 to 50,1 ± 0,2  | 33,2 to 39,10 ± 0,2  |  |  |  |
| 100                  | 35,2 to 35,5 ± 0,2                                | 31,8 to 32,2 ± 0,2  | 169,8 ± 0,5                          | 156,4 ± 0,5                       | 2,7 to 3,1 ± 0,2  | 47,65 ± 0,2          | 41,45 ± 0,2          |  |  |  |

<sup>a</sup> For the specification of the inner diameter, the specification of the plunger shall be considered with regard to break loose force and sustaining force as well as for plunger/barrel seal tightness. The size of the inner diameter also depends on the polymer material.

<sup>b</sup> This range is dedicated to barrels with an integrated Luer lock.

<sup>c</sup> Long.

<sup>d</sup> Short or standard.

<sup>e</sup> This range is required in order to consider particular applications, such as pumps and injectors.

## 5.2 Design requirements

### 5.2.1 Head design

The type of head design shall be agreed upon between the provider of the barrel component and the customer responsible for filling and finishing the polymer prefilled syringe. For the Luer tip and the Luer lock design, ISO 80369-7 shall apply. [Annex B](#) includes certain examples of head designs.

### 5.2.2 Dead space

When tested in combination with the selected plunger stopper, the dead space in the barrel and the tip with the plunger stopper fully inserted shall be determined as given in ISO 7886-1. Specification should be agreed upon between the manufacturer and customer.

### 5.2.3 Functional testing of Luer cone/Luer lock connection

The functional performance of the polymer prefilled syringe barrel with regard to the Luer tip or Luer lock connection shall be demonstrated through performance testing in accordance with ISO 80369-7.

### 5.2.4 Flange breakage resistance

Syringe barrels shall provide an appropriate flange breakage resistance. Limit values are subject to agreement between the manufacturer and the customer.

The flange breakage resistance shall be determined in accordance with [C.1](#).

NOTE The flange breakage resistance test method is a reference test to provide a consistent measure for comparison of the performance of different syringes and can potentially be used as a quality measure to assess changes and monitor production. The test method can be adjusted to simulate specific use conditions of the syringe system, e.g. use in auto-injectors.

### 5.2.5 Syringe tip breakage resistance

Syringe barrels shall provide an appropriate syringe tip breakage resistance. Limit values are subject to agreement between the manufacturer and the customer.

The syringe tip breakage resistance shall be determined in accordance with [C.2](#).

Diameter of syringe holder according to [Figure C.4](#) shall be adjusted to the syringe outer diameter given in [Table C.1](#).

NOTE The syringe tip breakage resistance test method is a reference test to provide a consistent measure for comparison of the performance of different syringes and can potentially be used as a quality measure to assess changes and monitor production. The test method can be adjusted to simulate specific use conditions of the syringe system, e.g. use in auto-injectors.

## 6 Requirements

### 6.1 General

The attention of the provider of the barrel component and the customer responsible for filling and finishing the plastic prefilled syringe is drawn to applicable performance requirements in monographs of, for example, the European Pharmacopoeia (Ph. Eur.), the United States Pharmacopoeia (USP) or the Japanese Pharmacopoeia (JP).

## ISO 11040-6:2019(E)

The manufacturer shall have documented procedures for the design and development of sterilized subassembled syringes ready for filling.

NOTE ISO 15378 and ISO 13485 contain requirements for a suitable quality management system for primary packaging materials for medicinal products.

### 6.2 Material

#### 6.2.1 General

The following properties should be considered when selecting the raw materials or components and the design of the sterilized subassembled syringe ready for filling:

- a) microbial barrier;
- b) biocompatibility and toxicological attributes;
- c) physical and chemical properties;
- d) ability for sterilization and compatibility with respect to the intended sterilization process;
- e) maintenance of sterility of the subassembly;
- f) shelf-life limitations;
- g) functionality regarding fill-finish;
- h) robustness of the closure system during transport from the manufacturer to the customer.

The material shall exhibit the appropriate performance properties, e.g. oxygen and water vapour permeability.

NOTE For guidance on materials, as well as polymer material codification, see [Annex I](#).

#### 6.2.2 Duty of notification concerning modifications to polymers

Change control and notification procedures, need to be in place between the company transforming the polymer into a syringe and the pharmaceutical company using it for injectable drug products.

NOTE 1 Requirements are given in ISO 15378 and ISO 13485.

NOTE 2 Particular attention is drawn to change control procedures and notification of changes by suppliers of raw material.

#### 6.2.3 Needle

**6.2.3.1** If the sterilized subassembled syringe ready for filling is delivered with a staked needle, the requirements in [6.2.3.2](#) to [6.2.3.5](#) apply.

**6.2.3.2** The needle shall fulfil the following material, dimensional, and design requirements:

- material and dimensions of the needle tubing shall be in accordance with ISO 9626; For tapered needles, needle manufacturers shall define how to apply the functional tests, specifically needle stiffness and resistance to breakage on the basis of a specific risk assessment carried out in accordance with ISO 14971;
- the bonding strength between the syringe and the needle shall be in accordance with ISO 7864;
- actual needle length shall be in accordance with ISO 7864:2016, Figure 2.