

CEN TC 88 WG 1

Date: 2016-08-26 draft 2011-12-08

ISO 16536:2019(E)

Deleted: /FDIS

ISO/TC 163/SC 1

Secretariat: DIN

Thermal insulating products for building applications — Determination of long-term water absorption by diffusion

Produits isolants thermiques destinés aux applications du bâtiment — Détermination de l'absorption d'eau à long terme par diffusion

iTeh STANDARD PREVIEW
(standards.iteh.ai)

[ISO 16536:2019](https://standards.iteh.ai/catalog/standards/sist/9d413fc5-f187-470c-97fa-8d6699c3350a/iso-16536-2019)

<https://standards.iteh.ai/catalog/standards/sist/9d413fc5-f187-470c-97fa-8d6699c3350a/iso-16536-2019>

Document type: International Standard

Document subtype:

Document stage: (60) Publication

Document language: E

STD Version 2.4e - RC2

ISO 16536:2019(E)

Foreword

ISO (the International Organization for Standardization) is a worldwide federation of national standards bodies (ISO member bodies). The work of preparing International Standards is normally carried out through ISO technical committees. Each member body interested in a subject for which a technical committee has been established has the right to be represented on that committee. International organizations, governmental and non-governmental, in liaison with ISO, also take part in the work. ISO collaborates closely with the International Electrotechnical Commission (IEC) on all matters of electrotechnical standardization.

The procedures used to develop this document and those intended for its further maintenance are described in the ISO/IEC Directives, Part 1. In particular the different approval criteria needed for the different types of ISO documents should be noted. This document was drafted in accordance with the editorial rules of the ISO/IEC Directives, Part 2 (see www.iso.org/directives).

Attention is drawn to the possibility that some of the elements of this document may be the subject of patent rights. ISO shall not be held responsible for identifying any or all such patent rights. Details of any patent rights identified during the development of the document will be in the Introduction and/or on the ISO list of patent declarations received (see www.iso.org/patents).

Any trade name used in this document is information given for the convenience of users and does not constitute an endorsement.

For an explanation of the voluntary nature of standards, the meaning of ISO specific terms and expressions related to conformity assessment, as well as information about ISO's adherence to the World Trade Organization (WTO) principles in the Technical Barriers to Trade (TBT) see: www.iso.org/iso/foreword.html.

This document was prepared by the European Committee for Standardization (CEN) Technical Committee CEN/TC 88, *Thermal insulating materials and products*, in collaboration with ISO Technical Committee TC 163, *Thermal performance and energy use in the built environment*, Subcommittee SC 1, *Test and measurement methods*, in accordance with the agreement on technical cooperation between ISO and CEN (Vienna Agreement).

This second edition cancels and replaces the first edition (ISO 16536:2012), which has been technically revised. The main changes compared to the previous edition are as follows:

- The content in 6.4 and 10 has been revised to reflect the conditions for tropical countries.

Any feedback or questions on this document should be directed to the user's national standards body. A complete listing of these bodies can be found at www.iso.org/members.html.

Thermal insulating products for building applications — Determination of long-term water absorption by diffusion

1 Scope

This document specifies the equipment and procedures for determining the long-term water absorption of test specimens by diffusion. It is applicable to thermal insulating products. It is intended to simulate the water absorption of products subjected to high relative humidities, approximating to 100 %, on both sides and subjected to a water vapour pressure gradient for a long period of time e.g. inverted roof or unprotected ground insulation.

The test is not applicable for all types of thermal insulating products. The relevant product standard should state for which of its products, if any, this test is applicable.

NOTE For unprotected ground insulation the temperature of 50 °C could be replaced by a lower temperature, when more data is available.

2 Normative references

The following documents are referred to in the text in such a way that some or all of their content constitutes requirements of this document. For dated references, only the edition cited applies. For undated references, the latest edition of the referenced document (including any amendments) applies.

ISO 29768, *Thermal insulating products for building applications — Determination of linear dimensions of test specimens*

3 Terms and definitions

No terms and definitions are listed in this document.

ISO and IEC maintain terminological databases for use in standardization at the following addresses:

- IEC Electropedia: available at <http://www.electropedia.org/>
- ISO Online browsing platform: available at <https://www.iso.org/obp>

4 Principle

The long-term water absorption by diffusion is determined by measuring the increase in the mass of a test specimen subjected to a water vapour pressure difference and temperature gradient for a period of 28 days.

5 Apparatus

5.1 **Balance**, capable of determining the mass of a specimen to an accuracy of 0,1 g.

ISO 16536:2019(E)

5.2 **Corrosion resistant container**, a frame supporting the test specimens.

5.3 **Heating device**, a thermostat, which provides water temperature control to $(50 \pm 1) ^\circ\text{C}$.

5.4 **Cooling plate**, thermally insulated on the outside, operating at a temperature of $(1 \pm 0,5) ^\circ\text{C}$.

5.5 **Tap water**, adjusted to a temperature of $(50 \pm 1) ^\circ\text{C}$.

The principle of the apparatus assembly is illustrated in Figure 1.

All dimensions in millimetres

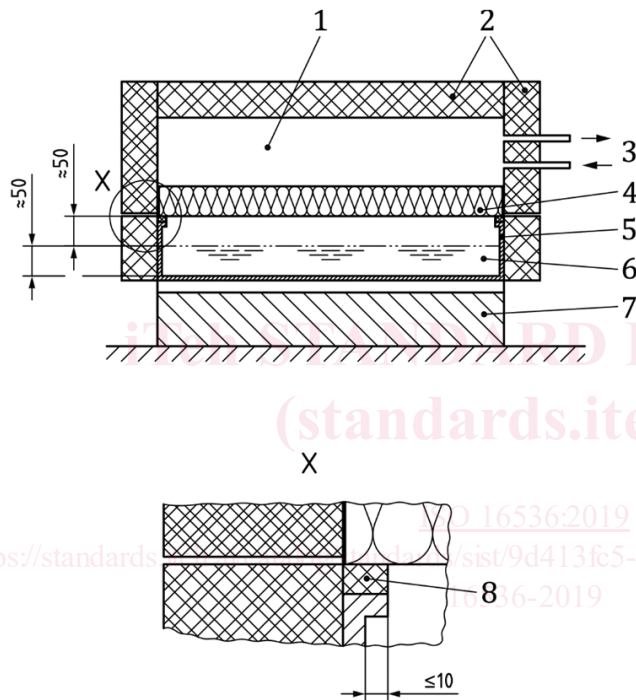

Key

- 1 cooling plate
- 2 thermal insulation of the cooling plate and the container
- 3 cooling medium inlet and outlet
- 4 test specimen
- 5 corrosion resistant container with a frame supporting the test specimen
- 6 tap water
- 7 heating device with a thermostat
- 8 sealing

Figure 1 — Example of test device for water absorption by diffusion

6 Test specimens

6.1 Dimensions of test specimens

The thickness of the test specimens shall be equal to the original product thickness.

The test specimens shall be primed with squarely cut edges having sides of (500 ± 1) mm. If the product is not large enough to permit this size of test specimen, the test specimen size shall be reduced accordingly. Test specimens shall not contain joints.

Deleted: with

6.2 Number of test specimens

The number of test specimens shall be at least two.

6.3 Preparation of test specimens

The test specimens shall be cut so that they do not include original product edges.

Test specimens shall be prepared by methods that do not substantially change the original structure of the product. Any facings, skins and/or coatings shall be retained.

Special methods of preparation, when needed, are given in the relevant product standard or any other technical specification.

6.4 Conditioning of test specimens

The test specimens shall be conditioned for at least 6 h at (23 ± 5) °C. In case of dispute they shall be stored at (23 ± 2) °C and (50 ± 5) % relative humidity for the time stated in the relevant product standard with a minimum of 6 h.

In tropical countries, different conditioning and testing conditions can be relevant. In this case, the conditions shall be (27 ± 2) °C (65 ± 5) RH (relative humidity), for at least 6 h and be stated clearly in the test report.

Deleted: Relative Humidity

7 Test procedure

The dimensions of the test specimens shall be measured in accordance with ISO 29768.

Weigh the test specimen to the nearest 0,1 g to determine its initial mass, m_0 .

Place the test specimen on the frame of the container. If the product is faced on one side, begin the test with the facing upwards. Seal the bottom edge of the test specimen to the container. The width of the sealing shall be ≤ 10 mm (see Figure 1). Place the insulated cooling plate on the top of the test specimen.

Subject the test specimen to a temperature and a water vapour pressure difference for 28 days by maintaining the water at a temperature of (50 ± 1) °C and the cooling on the other side at a temperature of $(1 \pm 0,5)$ °C.

Weigh and turn the test specimen over every 7 days.

After 28 days remove the test specimen and wipe off any surface water. Weigh the test specimen again to determine its mass, m_0 .

8 Calculation and expression of results

The test result, W_{dp} or W_{dV} , shall be the mean value of the individual values.

Results shall not be extrapolated to other thicknesses.

ISO 16536:2019(E)

Calculate the long-term water absorption by diffusion for each test specimen, W_{dp} or W_{dV} , in kilograms per square metre or volume per cent using Formula (1) or Formula (2).

$$W_{dp} = \frac{m_D - m_0}{A_p} \quad (1)$$

$$W_{dV} = \frac{m_D - m_0}{A_p \times d} \times \frac{100}{\rho_W} \quad (2)$$

iTeh STANDARD REVIEW
(standards.teh) a i

ISO 16536:2019(E) :
<http://standards.teh.org.cn/catalog/standards/sist/914-481-973-80-fd63-6-iso-16536-2019-1-62-50-31-69->

where

- m_0 is the initial mass of the test specimen, in kilograms;
- m_D is the mass of the test specimen after submission to water absorption by diffusion for 28 days, in kilograms;
- A_p is the bottom surface area of the test specimen, in square metres;
- d is the thickness of the test specimen, in metres;
- ρ_w is the density of water, assumed to be 1 000 kg/m³;
- W_{dp} shall be rounded to the nearest 0,01 kg/m²;
- W_{dv} shall be rounded to the nearest 0,1 volume per cent.

9 Accuracy of measurement

No statement on the accuracy of measurement is possible in this edition of this document.

10 Test report

The test report shall include the following information:

- a) reference to this document;
- b) product identification:
 - 1) product name, factory, manufacturer or supplier;
 - 2) production code number;
 - 3) type of product;
 - 4) packaging;
 - 5) the form in which the product arrived at the laboratory;
 - 6) other information as appropriate, e.g. nominal thickness, nominal density;
- c) test procedure:
 - 1) pre-test history and sampling, e.g. who sampled and place of sampling;
 - 2) conditioning;
 - 3) if any deviation from Clauses 5 and 6;
 - 4) date of testing;
 - 5) conditioning in tropical countries, if applicable;
 - 6) general information relating to the test;
 - 7) events which may have affected the results;

ISO 16536:2019(E)

d) results: all individual values and the mean value.

Information about the apparatus and identity of the technician should be available in the laboratory but it need not be recorded in the report.

iTeh STANDARD PREVIEW
(standards.iteh.ai)

ISO 16536:2019

<https://standards.iteh.ai/catalog/standards/sist/9d413fc5-f187-470c-97fa-8d6699c3350a/iso-16536-2019>