

---

---

**Non-destructive testing of welds —  
Ultrasonic testing — Techniques,  
testing levels, and assessment**

*Essais non destructifs des assemblages soudés — Contrôle par  
ultrasons — Techniques, niveaux d'essai et évaluation*

**iTeh STANDARD PREVIEW**  
**(standards.iteh.ai)**

[ISO 17640:2017](https://standards.iteh.ai/catalog/standards/sist/04772d1a-fla2-4e92-8c16-29b185bac9f7/iso-17640-2017)

[https://standards.iteh.ai/catalog/standards/sist/04772d1a-fla2-4e92-8c16-  
29b185bac9f7/iso-17640-2017](https://standards.iteh.ai/catalog/standards/sist/04772d1a-fla2-4e92-8c16-29b185bac9f7/iso-17640-2017)



**iTeh STANDARD PREVIEW**  
**(standards.iteh.ai)**

ISO 17640:2017

<https://standards.iteh.ai/catalog/standards/sist/04772d1a-fla2-4e92-8c16-29b185bac9f7/iso-17640-2017>



**COPYRIGHT PROTECTED DOCUMENT**

© ISO 2017, Published in Switzerland

All rights reserved. Unless otherwise specified, no part of this publication may be reproduced or utilized otherwise in any form or by any means, electronic or mechanical, including photocopying, or posting on the internet or an intranet, without prior written permission. Permission can be requested from either ISO at the address below or ISO's member body in the country of the requester.

ISO copyright office  
Ch. de Blandonnet 8 • CP 401  
CH-1214 Vernier, Geneva, Switzerland  
Tel. +41 22 749 01 11  
Fax +41 22 749 09 47  
copyright@iso.org  
www.iso.org

# Contents

	Page
Foreword .....	iv
<b>1 Scope .....</b>	<b>1</b>
<b>2 Normative references .....</b>	<b>1</b>
<b>3 Terms and definitions .....</b>	<b>2</b>
<b>4 Symbols .....</b>	<b>2</b>
<b>5 Principle .....</b>	<b>3</b>
<b>6 Information required prior to testing .....</b>	<b>3</b>
6.1 Items to be specified .....	3
6.2 Specific information required before testing .....	3
6.3 Written test procedure .....	4
<b>7 Requirements for personnel and equipment .....</b>	<b>4</b>
7.1 Personnel qualifications .....	4
7.2 Test equipment .....	4
7.3 Probe parameters .....	4
7.3.1 Test frequency .....	4
7.3.2 Angles of incidence .....	4
7.3.3 Element size .....	5
7.3.4 Adaptation of probes to curved scanning surfaces .....	5
7.3.5 Coupling media .....	5
<b>8 Testing volume .....</b>	<b>5</b>
<b>9 Preparation of scanning surfaces .....</b>	<b>6</b>
<b>10 Parent metal testing .....</b>	<b>6</b>
<b>11 Range and sensitivity setting .....</b>	<b>7</b>
11.1 General .....	7
11.2 Reference for sensitivity setting .....	8
11.3 Evaluation levels .....	9
11.4 Transfer correction .....	9
11.5 Signal-to-noise ratio .....	9
<b>12 Testing levels .....</b>	<b>9</b>
<b>13 Testing techniques .....</b>	<b>10</b>
13.1 General .....	10
13.2 Manual scan path .....	10
13.3 Testing for imperfections perpendicular to the testing surface .....	10
13.4 Location of discontinuities .....	10
13.5 Evaluation of indications .....	10
13.5.1 General .....	10
13.5.2 Maximum echo amplitude .....	10
13.5.3 Discontinuity length .....	11
13.5.4 Discontinuity height .....	11
13.5.5 Characterization of discontinuities .....	11
<b>14 Test report .....</b>	<b>11</b>
<b>Annex A (normative) Testing levels for various types of welded joints .....</b>	<b>13</b>
<b>Bibliography .....</b>	<b>29</b>

## Foreword

ISO (the International Organization for Standardization) is a worldwide federation of national standards bodies (ISO member bodies). The work of preparing International Standards is normally carried out through ISO technical committees. Each member body interested in a subject for which a technical committee has been established has the right to be represented on that committee. International organizations, governmental and non-governmental, in liaison with ISO, also take part in the work. ISO collaborates closely with the International Electrotechnical Commission (IEC) on all matters of electrotechnical standardization.

The procedures used to develop this document and those intended for its further maintenance are described in the ISO/IEC Directives, Part 1. In particular the different approval criteria needed for the different types of ISO documents should be noted. This document was drafted in accordance with the editorial rules of the ISO/IEC Directives, Part 2 (see [www.iso.org/directives](http://www.iso.org/directives)).

Attention is drawn to the possibility that some of the elements of this document may be the subject of patent rights. ISO shall not be held responsible for identifying any or all such patent rights. Details of any patent rights identified during the development of the document will be in the Introduction and/or on the ISO list of patent declarations received (see [www.iso.org/patents](http://www.iso.org/patents)).

Any trade name used in this document is information given for the convenience of users and does not constitute an endorsement.

For an explanation on the voluntary nature of standards, the meaning of ISO specific terms and expressions related to conformity assessment, as well as information about ISO's adherence to the World Trade Organization (WTO) principles in the Technical Barriers to Trade (TBT) see the following URL: [www.iso.org/iso/foreword.html](http://www.iso.org/iso/foreword.html). (standards.iteh.ai)

This document was prepared by Technical Committee ISO/TC 44, *Welding and allied processes*, Subcommittee SC 5, *Testing and inspection of welds*. ISO 17640:2017

This third edition cancels and replaces the second edition (ISO 17640:2010), which has been technically revised. <https://standards.iteh.ai/catalog/standards/sist/04772d1a-fla2-4e92-8c16-32bc185d-4d1f>

Requests for official interpretations of any aspect of this document should be directed to the Secretariat of ISO/TC 44/SC 5 via your national standards body. A complete listing of these bodies can be found at [www.iso.org](http://www.iso.org).

# Non-destructive testing of welds — Ultrasonic testing — Techniques, testing levels, and assessment

## 1 Scope

This document specifies techniques for the manual ultrasonic testing of fusion-welded joints in metallic materials of thickness  $\geq 8$  mm which exhibit low ultrasonic attenuation (especially that due to scatter) at object temperatures from 0 °C to 60 °C. It is primarily intended for use on full penetration welded joints where both the welded and parent material are ferritic.

Where material-dependent ultrasonic values are specified in this document, they are based on steels having an ultrasonic sound velocity of  $(5\,920 \pm 50)$  m/s for longitudinal waves and  $(3\,255 \pm 30)$  m/s for transverse waves.

This document specifies four testing levels, each corresponding to a different probability of detection of imperfections. Guidance on the selection of testing levels A, B, and C is given in [Annex A](#).

This document specifies that the requirements of testing level D, which is intended for special applications, be in accordance with general requirements. Testing level D can only be used when defined by specification. This includes tests of metals other than ferritic steel, tests on partial penetration welds, tests with automated equipment, and tests at object temperatures outside the range 0 °C to 60 °C.

This document can be used for the assessment of discontinuities, for acceptance purposes, by either of the following techniques:

- a) evaluation based primarily on length and echo amplitude of the discontinuity;
- b) evaluation based on characterization and sizing of the discontinuity by probe movement techniques.

## 2 Normative references

The following documents are referred to in the text in such a way that some or all of their content constitutes requirements of this document. For dated references, only the edition cited applies. For undated references, the latest edition of the referenced document (including any amendments) applies.

ISO 5577, *Non-destructive testing — Ultrasonic testing — Vocabulary*

ISO 9712, *Non-destructive testing — Qualification and certification of NDT personnel*

ISO 11666:2010, *Non-destructive testing of welds — Ultrasonic testing — Acceptance levels*

ISO 16810, *Non-destructive testing — Ultrasonic testing — General principles*

ISO 16811, *Non-destructive testing — Ultrasonic testing — Sensitivity and range setting*

ISO 16826, *Non-destructive testing — Ultrasonic testing — Examination for discontinuities perpendicular to the surface*

ISO 17635, *Non-destructive testing of welds — General rules for metallic materials*

ISO 23279, *Non-destructive testing of welds — Ultrasonic testing — Characterization of discontinuities in welds*

EN 12668 (all parts), *Non-destructive testing — Characterization and verification of ultrasonic examination equipment*

### 3 Terms and definitions

For the purposes of this document, the terms and definitions given in ISO 5577 and ISO 17635 apply.

ISO and IEC maintain terminological databases for use in standardization at the following addresses:

- IEC Electropedia: available at <http://www.electropedia.org/>
- ISO Online browsing platform: available at <http://www.iso.org/obp>

### 4 Symbols

Symbol	Definition	Unit
AL	acceptance level	—
$D_{DSR}$	diameter of the disk-shaped reflector (flat-bottom hole)	mm
$h$	extension of the discontinuity in depth direction	mm
$l$	length of the discontinuity	mm
$l_x$	projected length of the discontinuity in the $x$ -direction	mm
$l_y$	projected length of the discontinuity in the $y$ -direction	mm
$p$	full skip distance	mm
$t$	thickness of parent material <sup>a</sup>	mm
$x$	position of the discontinuity in the longitudinal direction	mm
$y$	position of the discontinuity in the transverse direction	mm
$z$	position of the discontinuity in the depth direction	mm

<sup>a</sup> If the joined parts are not of equal thickness,  $t$  represents the smallest thickness.

Indications shall be considered to be originating from either longitudinal or transverse discontinuities, depending on the direction of their major dimension with respect to the weld axis,  $x$ , in accordance with [Figure 1](#).

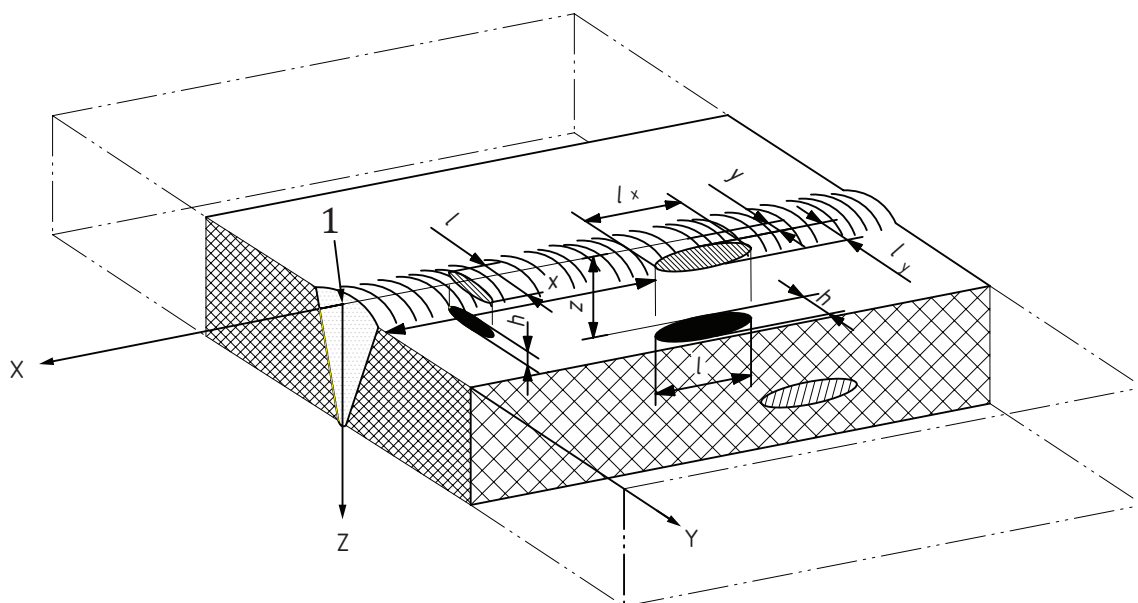

**Key**

1 origin

NOTE For definitions of  $h$ ,  $l$ ,  $l_x$ ,  $l_y$ ,  $x$ ,  $y$ ,  $z$ , see table above.

**Figure 1 — Coordinate system for defining the location of discontinuities**

## 5 Principle

The purpose of this document is to describe general techniques of ultrasonic weld testing, using standard criteria, for the most commonly used welded joints at object temperatures in the range 0 °C to 60 °C. The specific requirements of this document cover the test equipment, preparation, performance of testing, and reporting. The parameters specified, in particular those for the probes, are compatible with the requirements of ISO 11666 and ISO 23279.

If the joined parts are not of equal thickness, the smallest thickness shall be considered.

The techniques used shall be specified.

## 6 Information required prior to testing

### 6.1 Items to be specified

These include:

- a) method for setting the reference level;
- b) method to be used for the evaluation of discontinuities;
- c) acceptance levels;
- d) testing level;
- e) manufacturing and operation stage(s) at which the testing is to be carried out;
- f) qualification of personnel;
- g) extent of the testing for transverse discontinuities;
- h) requirements for additional tandem testing (according to ISO 16826);
- i) parent metal testing prior to and/or after welding;
- j) whether or not a written test procedure is required;
- k) requirements for written test procedures.

### 6.2 Specific information required before testing

Before any testing of a welded joint can begin, the operator shall have access to the following essential information:

- a) written test procedure, if required (see 6.3);
- b) type(s) of parent material and product form (i.e. cast, forged, rolled);
- c) manufacturing or operation stage at which testing is to be made, including heat treatment, if any;
- d) time and extent of any post-weld heat treatment;
- e) joint preparation and dimensions;
- f) requirements for surface conditions;
- g) welding procedure or relevant information on the welding process;
- h) reporting requirements;
- i) acceptance levels;

- j) extent of testing, including requirements for transverse discontinuities, if relevant;
- k) testing level;
- l) personnel qualification level;
- m) procedures for corrective actions when unacceptable discontinuities are revealed.

### **6.3 Written test procedure**

The definitions and requirements in this document normally satisfy the need for a written test procedure.

Where this is not the case, or where the techniques described in this document are not applicable to the weld joint to be tested, additional written test procedures shall be used, if required by specification.

## **7 Requirements for personnel and equipment**

### **7.1 Personnel qualifications**

Personnel performing testing in accordance with this document shall be qualified to an appropriate level in ultrasonic testing in accordance with ISO 9712 or equivalent in the relevant industrial sector.

In addition to a general knowledge of ultrasonic weld testing, personnel shall also be familiar with testing problems specifically associated with the type of welded joints to be tested.

### **7.2 Test equipment**

Any equipment used for testing in conjunction with this document shall comply with the requirements of EN 12668 (all parts).

### **7.3 Probe parameters**

#### **7.3.1 Test frequency**

The frequency shall be within the range 2 MHz to 5 MHz and shall be selected to consider the properties of the test object and to comply with the specified acceptance levels, for example, of ISO 11666.

Higher frequencies may be used to improve range resolution if this is necessary when using standards for acceptance levels based on characterization of discontinuities, e.g. ISO 23279.

Lower frequencies may be used for testing at long sound paths and/or when the material shows high attenuation.

#### **7.3.2 Angles of incidence**

When testing is carried out with transverse waves and techniques that require the ultrasonic beam to be reflected from an opposite surface, care shall be taken to ensure that the angle between the beam and the normal to the opposite reflecting surface is between 35° and 70°. Where more than one beam angle is used, at least one of the angle-beam probes used shall conform to this requirement. One of the beam angles used shall ensure that the weld fusion faces are tested at, or as near as possible to, normal incidence. When the use of two or more beam angles is specified, the difference between the nominal beam angles shall be 10° or greater.

Angles of incidence at the probe and opposite reflecting surface, when curved, may be determined by drawing a sectional view of the weld or in accordance with the techniques given in ISO 16811. Where angles of incidence cannot be determined as specified by this document, the test report shall contain



a comprehensive description of the scans used and the extent of any incomplete coverage caused, together with an explanation of the difficulties encountered.

### 7.3.3 Element size

The element size shall be chosen according to the ultrasonic path to be used and the frequency.

The smaller the element, the smaller the length and width of the near field, and the larger the beam spread in the far field at a given frequency.

Small probes having 6 mm to 12 mm diameter elements (or rectangular elements of equivalent area) are therefore most useful when working at short sound paths. For longer sound paths, i.e. greater than 100 mm for single straight-beam probes and greater than 200 mm for angle-beam probes, an element size of 12 mm to 24 mm is more suitable.

### 7.3.4 Adaptation of probes to curved scanning surfaces

The gap,  $g$ , between test surface and bottom of the probe shall not be greater than 0,5 mm.

For flat probes on cylindrical or spherical surfaces, this requirement can be checked with [Formula \(1\)](#):

$$g = a^2/4D \quad (1)$$

where

$a$  is the dimension of the probe in the direction of curvature, in mm;

$D$  is the diameter of the test object, in mm.

If a value for  $g$  larger than 0,5 mm results from the formula, the probe shall be adapted to the surface and the sensitivity and range shall be set accordingly.

For spherical or complex shaped surfaces, [Formula \(1\)](#) shall be applied in both length and width direction of the probe (possible differences in curvature and/or probe dimensions).

### 7.3.5 Coupling media

The coupling media shall be in accordance with ISO 16810. The coupling medium used for range and sensitivity setting and for the test shall be the same.

## 8 Testing volume

The testing volume (see [Figure 2](#)) is defined as the zone which includes weld and parent material and the width of the heat-affected zone on each side of the weld or at least 10 mm if the width of the heat-affected zone is not known.

In all cases, scanning shall cover the whole testing volume. If individual sections of this volume cannot be covered in at least one scanning direction, or if the angles of incidence with the opposite surface do not meet the requirements of [7.3.2](#), alternative or supplementary ultrasonic techniques or other non-destructive techniques shall be agreed upon. This may, in some cases, require removal of the weld reinforcement.

Supplementary techniques can require testing using dual-element angle-beam probes, creeping wave probes, further ultrasonic techniques or any other suitable method, e.g. liquid penetrant, magnetic particle, radiographic testing. In selecting alternative or supplementary techniques, due consideration should be given to the type of weld and probable orientation of any imperfections to be detected.

## 9 Preparation of scanning surfaces

Scanning surfaces shall be wide enough to permit the testing volume (see [Figure 2](#)) to be fully covered. Alternatively, the width of the scanning surfaces may be smaller if equivalent coverage of the testing volume can be achieved by scanning from both the upper and the lower surface of the joint.

Scanning surfaces shall be even and free from foreign matter likely to interfere with probe coupling (e.g. rust, loose scale, weld spatter, notches, grooves). Waviness of the test surface shall not result in a gap between the probe and test surfaces greater than 0,5 mm. These requirements shall be ensured by dressing, if necessary. Local variations in surface contour, e.g. along the edge of the weld, which result in a gap beneath the probe of up to 1 mm, can only be permitted if at least one additional beam angle is employed from the affected side at the weld. This additional scanning is necessary to compensate for the reduced weld coverage that will occur with a gap of this dimension.

Scanning surfaces and surfaces from which the sound beam is reflected shall allow undisturbed coupling and reflection.

## 10 Parent metal testing

The parent metal, in the scanning zone area (see [Figure 2](#)), shall be tested with straight-beam probes prior to or after welding, unless it can be demonstrated (e.g. by previous testing during the fabrication process) that the angle-beam testing of the weld is not influenced by the presence of the imperfections or high attenuation.

Where imperfections are found, their influence on the proposed angle-beam testing shall be assessed and, if necessary, the techniques adjusted correspondingly. When satisfactory coverage by ultrasonic testing is seriously affected, other test techniques (e.g. radiographic testing) shall be considered.

ISO 17640:2017

<https://standards.iteh.ai/catalog/standards/sist/04772d1a-fla2-4e92-8c16-29b185bac9f7/iso-17640-2017>

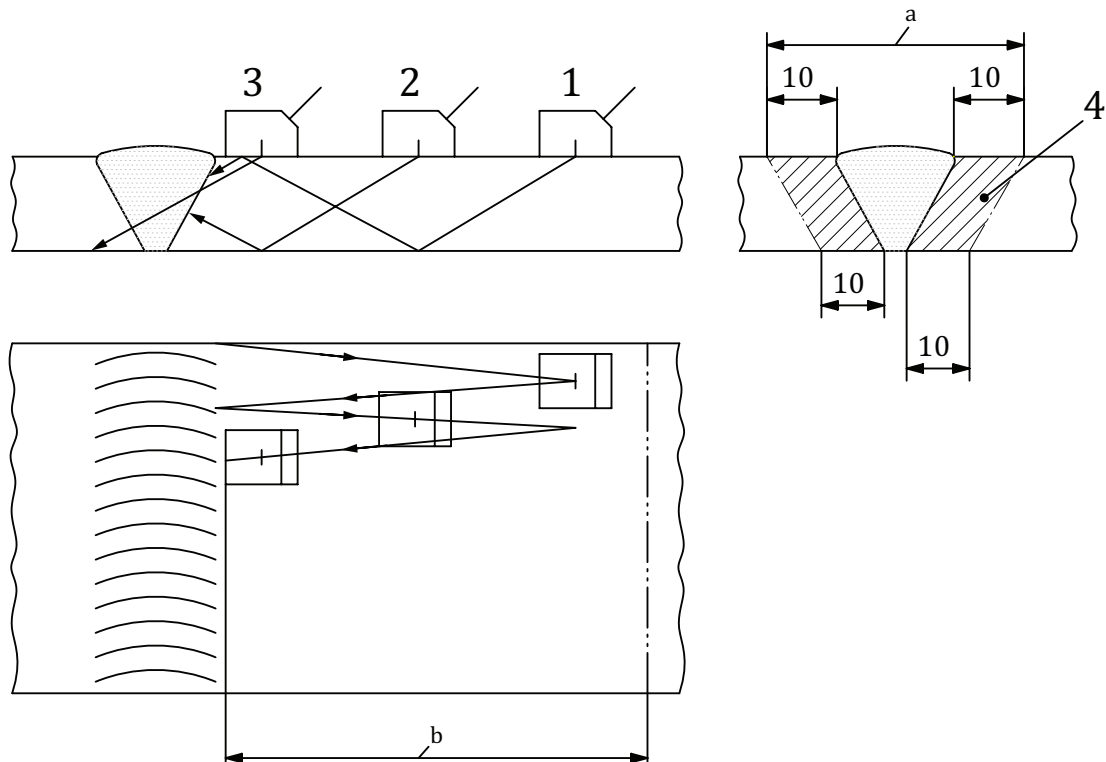

**iTeh STANDARD PREVIEW**  
(standards.iteh.ai)

**Key**

- 1 position 1, taking into account the width of the heat-affected zone
- 2 position 2
- 3 position 3
- 4 heat-affected zone
- a Width of testing volume.
- b Scanning zone width, not including the width of the weld because of the presence of the weld reinforcement.

**Figure 2 — Example of testing volume to be covered when scanning for longitudinal discontinuities**

## 11 Range and sensitivity setting

### 11.1 General

Setting of range and sensitivity shall be carried out prior to each testing in accordance with this document and ISO 16811, taking the influence of temperature into account. The temperature difference during range and sensitivity setting and during the test shall be within  $\pm 15$  °C.

Checks to confirm these settings shall be performed at least every 4 h and upon completion of the testing. Checks shall also be carried out whenever a system parameter is changed or changes in the equivalent settings are suspected.

If deviations greater than 2 dB, resp. 1 % of range, are found during these checks, the corrections given in [Table 2](#) shall be carried out.

**Table 2 — Sensitivity and range corrections**

Sensitivity		
1	Deviations $\leq 2$ dB	No action required.
2	$2 \text{ dB} < \text{deviation} \leq 4 \text{ dB}$	Setting shall be corrected before the testing is continued.
3	Reduction of the sensitivity $> 4 \text{ dB}$	Setting shall be corrected and all testing carried out with the equipment over the previous period shall be repeated.
4	Increase in sensitivity $> 4 \text{ dB}$	Setting shall be corrected and all recorded indications shall be re-examined.
Range		
1	Deviations $< 1 \%$ of the range	No action required.
2	$1 \%$ of the range $< \text{deviation} \leq 2 \%$ of the range	Setting shall be corrected before testing is continued.
3	Deviations $> 2 \%$ of the range	Setting shall be corrected and testing carried out with the equipment over the previous period shall be repeated.

**11.2 Reference for sensitivity setting**

One of the following techniques for setting the reference shall be used.

The use of these techniques may not result in equal test results.

Different testing results may occur by usage of different techniques for sensitivity setting.

- Technique 1: the reference is a distance-amplitude curve (DAC) for side-drilled holes of diameter 3 mm.
- Technique 2: the references for transverse and longitudinal waves using the distance-gain-size (DGS) system based on the diameter of the disk-shaped reflectors ( $D_{DSR}$ ) are given in [Tables 3](#) and [4](#), respectively.
- Technique 3: the reference notch shall be 1 mm wide, rectangular, with a depth of 1 mm. This technique applies only for the thickness range  $8 \text{ mm} \leq t < 15 \text{ mm}$  and only for beam angles  $\geq 70^\circ$ .
- Technique 4: for the tandem technique, the reference is a disk-shaped reflector (flat-bottom hole) of 6 mm diameter (for all thicknesses), perpendicular to the scanning surface. This technique is applicable only for beam angle  $45^\circ$  and thickness  $t \geq 40 \text{ mm}$ .

The length of the side-drilled holes and notches shall be greater than the width of the sound beam at  $-20 \text{ dB}$  amplitude.

**Table 3 — Reference levels for acceptance levels 2 and 3 for technique 2 using angle-beam scanning with transverse waves**

Nominal probe frequency MHz	Thickness of parent material, $t$					
	$8 \text{ mm} \leq t < 15 \text{ mm}$		$15 \text{ mm} \leq t < 40 \text{ mm}$		$40 \text{ mm} \leq t < 100 \text{ mm}$	
	AL 2	AL 3	AL 2	AL 3	AL 2	AL 3
2,0 to 2,5	—	—	$D_{DSR} = 2,5 \text{ mm}$	$D_{DSR} = 2,5 \text{ mm}$	$D_{DSR} = 3,0 \text{ mm}$	$D_{DSR} = 3,0 \text{ mm}$
3,0 to 5,0	$D_{DSR} = 1,5 \text{ mm}$	$D_{DSR} = 1,5 \text{ mm}$	$D_{DSR} = 2,0 \text{ mm}$	$D_{DSR} = 2,0 \text{ mm}$	$D_{DSR} = 3,0 \text{ mm}$	$D_{DSR} = 3,0 \text{ mm}$

$D_{DSR}$  is the diameter of the disk-shaped reflector.