Ceramic tiles —

**Part 4:
Determination of modulus of rupture
and breaking strength**

Carreaux et dalles céramiques —

*Partie 4. Détermination de la résistance à la flexion et de la force
de rupture*

**iTeh STANDARD PREVIEW
(standards.iteh.ai)**

ISO 10545-4:2019

<https://standards.iteh.ai/catalog/standards/sist/6e29aa24-fe6a-4a77-9014-16cd326d9700/iso-10545-4-2019>



iTeh STANDARD PREVIEW
(standards.iteh.ai)

ISO 10545-4:2019

<https://standards.iteh.ai/catalog/standards/sist/6e29aa24-fe6a-4a77-9014-16cd326d9700/iso-10545-4-2019>



COPYRIGHT PROTECTED DOCUMENT

© ISO 2019

All rights reserved. Unless otherwise specified, or required in the context of its implementation, no part of this publication may be reproduced or utilized otherwise in any form or by any means, electronic or mechanical, including photocopying, or posting on the internet or an intranet, without prior written permission. Permission can be requested from either ISO at the address below or ISO's member body in the country of the requester.

ISO copyright office
CP 401 • Ch. de Blandonnet 8
CH-1214 Vernier, Geneva
Phone: +41 22 749 01 11
Fax: +41 22 749 09 47
Email: copyright@iso.org
Website: www.iso.org

Published in Switzerland

Contents

	Page
Foreword	iv
1 Scope	1
2 Normative references	1
3 Terms and definitions	1
4 Principle	2
5 Apparatus	2
6 Test specimens	3
7 Procedure	6
8 Calculation	6
9 Test report	7
Bibliography	8

iTeh STANDARD PREVIEW (standards.iteh.ai)

[ISO 10545-4:2019](https://standards.iteh.ai/catalog/standards/sist/6e29aa24-fe6a-4a77-9014-16cd326d9700/iso-10545-4-2019)

<https://standards.iteh.ai/catalog/standards/sist/6e29aa24-fe6a-4a77-9014-16cd326d9700/iso-10545-4-2019>

Foreword

ISO (the International Organization for Standardization) is a worldwide federation of national standards bodies (ISO member bodies). The work of preparing International Standards is normally carried out through ISO technical committees. Each member body interested in a subject for which a technical committee has been established has the right to be represented on that committee. International organizations, governmental and non-governmental, in liaison with ISO, also take part in the work. ISO collaborates closely with the International Electrotechnical Commission (IEC) on all matters of electrotechnical standardization.

The procedures used to develop this document and those intended for its further maintenance are described in the ISO/IEC Directives, Part 1. In particular, the different approval criteria needed for the different types of ISO documents should be noted. This document was drafted in accordance with the editorial rules of the ISO/IEC Directives, Part 2 (see www.iso.org/directives).

Attention is drawn to the possibility that some of the elements of this document may be the subject of patent rights. ISO shall not be held responsible for identifying any or all such patent rights. Details of any patent rights identified during the development of the document will be in the Introduction and/or on the ISO list of patent declarations received (see www.iso.org/patents).

Any trade name used in this document is information given for the convenience of users and does not constitute an endorsement.

For an explanation of the voluntary nature of standards, the meaning of ISO specific terms and expressions related to conformity assessment, as well as information about ISO's adherence to the World Trade Organization (WTO) principles in the Technical Barriers to Trade (TBT) see www.iso.org/iso/foreword.html.

This document was prepared by Technical Committee ISO/TC 189, *Ceramic tile*.

Any feedback or questions on this document should be directed to the user's national standards body. A complete listing of these bodies can be found at www.iso.org/members.html.

This fourth edition cancels and replaces the third edition (ISO 10545-4:2014), which has been technically revised. The main changes compared to the previous edition are as follows:

- test specimens are tested in different format size according to their work size thickness that can be minor or greater/equal than 7,5 mm;
- the minimum number of specimen to be tested has been changed.

A list of all parts in the ISO 10545 series can be found on the ISO website.

Ceramic tiles —

Part 4: Determination of modulus of rupture and breaking strength

1 Scope

This document specifies a test method for determining the modulus of rupture and breaking strength of all ceramic tiles.

NOTE ISO 13006 provides property requirements for tiles and other useful information on these products.

2 Normative references

The following documents are referred to in the text in such a way that some or all of their content constitutes requirements of this document. For dated references, only the edition cited applies. For undated references, the latest edition of the referenced document (including any amendments) applies.

ISO 48-2, *Rubber, vulcanized or thermoplastic — Determination of hardness — Part 2: Hardness between 10 IRHD and 100 IRHD*

3 Terms and definitions

For the purposes of this document, the following terms and definitions apply.

ISO and IEC maintain terminological databases for use in standardization at the following addresses:

- ISO Online browsing platform: available at <https://www.iso.org/obp>
- IEC Electropedia: available at <http://www.electropedia.org/>

3.1 breaking load

F

force necessary to cause the test specimen to break, as read from the pressure gauge (see [Figure 1](#))

3.2 breaking strength

S

force obtained by multiplying the *breaking load* ([3.1](#)) by the ratio (span between support rods)/(width of the test specimen)

3.3 modulus of rupture

R

quantity obtained by dividing the calculated *breaking strength* ([3.2](#)) by the square of the minimum thickness along the broken edge

3.4 work size thickness

thickness of the tile specified by the manufacturer

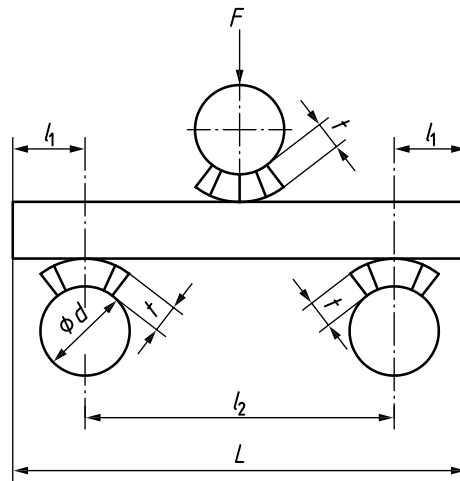

Key

- d diameter of rod
- L long side of tile
- l_1 overlap of tile beyond the edge supports
- l_2 span between the support rods
- t thickness of rubber

Figure 1 — Application of load to test specimens
(standards.iteh.ai)

4 Principle

Determination of the breaking load, breaking strength, and modulus of rupture of a tile by applying a force at a specified rate to the centre of the tile, the point of application being in contact with the proper surface of the tile.

5 Apparatus

5.1 Drying oven, capable of being operated at $(105 \pm 5) ^\circ\text{C}$.

Microwave, infrared or other drying systems can be used provided that it has been determined that equal results are obtained.

5.2 Recording pressure gauge, accurate to 2,0 %.

5.3 Two cylindrical support rods, made of metal, the parts in contact with the test specimens being covered with rubber having a hardness of (50 ± 5) IRHD, measured in accordance with ISO 48-2.

One rod shall be slightly pivotable (see [Figure 2](#)) and the other shall be slightly rotatable about its own axis. See [Table 1](#) for relevant dimensions.

Table 1 — Diameter of rods, d , thickness of rubber, t , and overlap of tile beyond the edge supports, l_1

Dimensions in millimetres

Long side of tile L	Diameter of rod d	Thickness of rubber t	Overlap of tile beyond the edge supports l_1
$18 \leq L < 48$	5 ± 1	$1 \pm 0,2$	2 ± 1
$48 \leq L < 95$	10 ± 1	$2,5 \pm 0,5$	5 ± 3
$L \geq 95$	20 ± 1	5 ± 1	10 ± 5

5.4 Central cylindrical rod, of the same diameter as the support rods (5.3) and covered with the same rubber, for transmission of the load.

This rod shall also be slightly pivotable (see Figure 2). See Table 1 for relevant dimensions.

5.5 Stiff brush, with coarse bristles for removing loose particles.

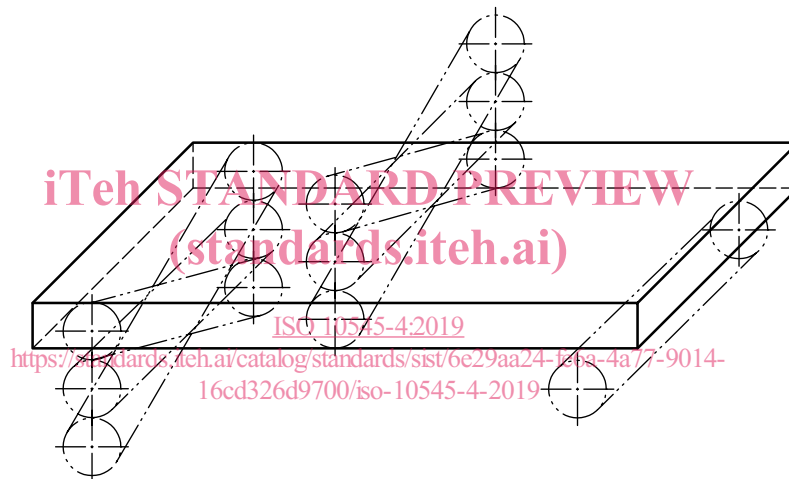
**Figure 2 — Allowable movement of rods**

6 Test specimens

6.1 If the tile has a work size thickness greater than or equal to 7,5 mm, select the tiles at random from the lot to be tested. Whenever possible, whole tiles shall be tested. However, it can be necessary to cut exceptionally large tiles (that is, those greater than 600 mm in length) in order to fit them in the apparatus. Test specimens of the largest possible size, though not larger than the rod length, shall then be cut, having their centres coinciding with the centres of the tiles. In case of doubt, results obtained using whole tiles shall always be preferred to results obtained with cut tiles. If cut tiles are used, it shall be noted in the test report and tolerance for cuts must be within 10 mm.

When aspect ratio is $L/B \leq 3$, where L is the long side of the tile and B is the short side of the tile,

- if $L \leq 600$ mm, then maintain the original dimension;
- if $L > 600$ mm, then maintain the original aspect ratio until $L = 600$ mm.

EXAMPLES

- (900 × 900) mm is cut to (600 × 600) mm,
- (1 200 × 600) mm is cut to (600 × 300) mm,
- (900 × 300) mm is cut to (600 × 200) mm,
- (1 800 × 900) mm is cut to (600 × 300) mm

When aspect ratio is $L/B > 3$, where L is the long side of the tile and B is the short side of the tile:

- if $L \leq 600$ mm, then maintain the original dimension;
- if $L > 600$ mm, reduce L to 600 mm, maintaining as much as possible the aspect ratio and cutting B not less than 250 mm (this means that if $B < 250$ mm, it shall maintain the original dimension).

EXAMPLES

- (1 800 × 500) mm is cut to (600 × 250) mm
- (1 200 × 300) mm is cut to (600 × 250) mm
- (1 200 × 200) mm is cut to (600 × 200) mm

6.2 If the tile has a work size thickness less than 7,5 mm, select the tiles at random from the lot to be tested. Whole tiles shall be tested when their maximum area is in the range 324 mm² to 40 000 mm². When tile maximum area is in the range 40 000 mm² to 360 000 mm², quadrangular test specimens of 200 mm × 200 mm size shall be cut, having their centres coinciding with the centres of the tiles (see [Figure 3](#)). For tiles with the short side, B , less than 200 mm and maximum area in the range 40 000 mm² to 360 000 mm², the test specimens shall be the dimension of the short side, B , by 200 mm, having their centres coinciding with the centres of the tiles (for example, a tile with dimensions of 1 000 × 150 mm would be cut to 200 × 150 mm for testing). When tile maximum area is greater than 360 000 mm² quadrangular test specimens of 200 mm × 200 mm size shall be cut as illustrated in [Figure 4](#).

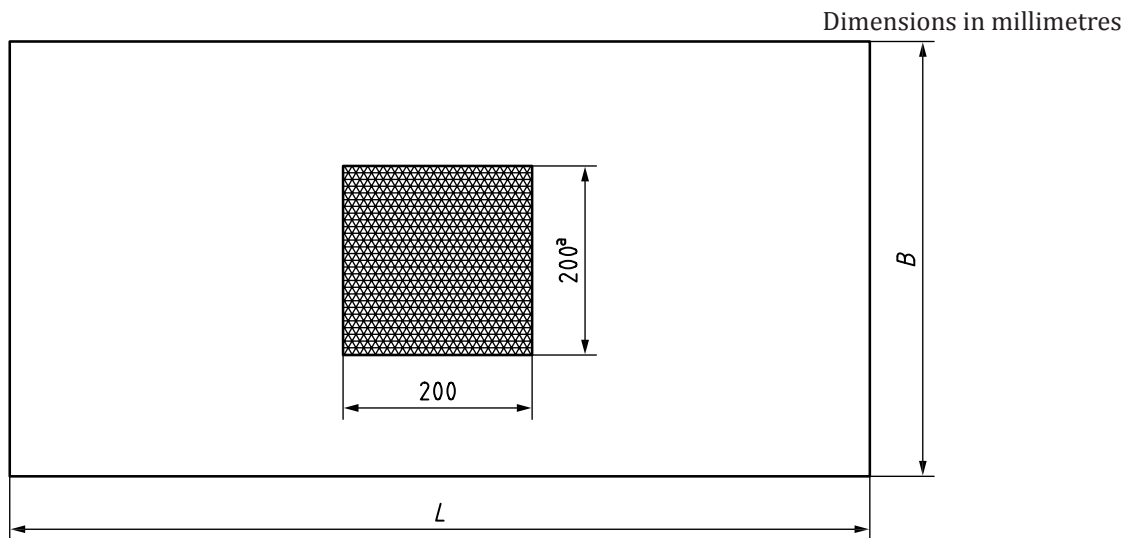

Key

- B short side of the tile
- L long side of the tile
- ^a Or B if $B \leq 200$ mm.

Figure 3 — Specimen for tile with a maximum area in the range 40 000 mm² to 360 000 mm² and work size thickness <7,5 mm

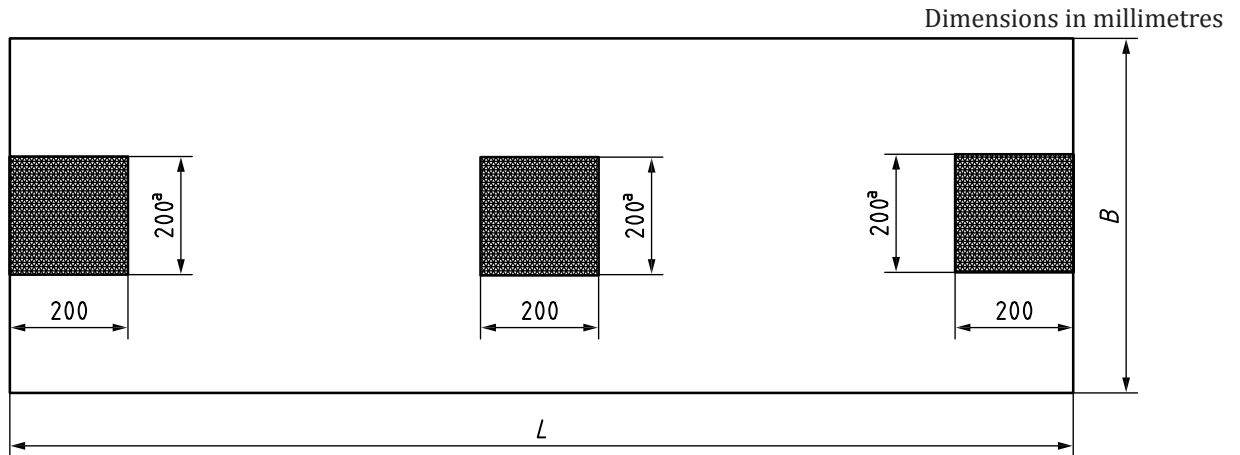

Key

- B* short side of the tile
- L* long side of the tile
- ^a Or *B* if $B \leq 200$ mm.

Figure 4 — Specimen for tile having a maximum area $>360\,000$ mm² and work size thickness $<7,5$ mm

iTeh STANDARD PREVIEW
(standards.iteh.ai)

6.3 Tiles and relevant specimens shall not contain any visible damage or cracks prior to testing and shall not have been tested previously.

ISO 10545-4:2019

6.4 The minimum number of test specimens for each sample when the tile has a work size thickness $\geq 7,5$ mm or $< 7,5$ mm is reported in [Table 2](#) and [Table 3](#), respectively.

https://standards.iteh.ai/catalog/standards/sist/6e29aa24-fe6a-4a77-9014-10c420b700/iso-10545-4-2019

Table 2 — Minimum number of test specimens for tiles with a work size thickness $\geq 7,5$ mm

Maximum area <i>A</i> mm ²	Number of specimens to be tested	Total number of tiles	Total number of specimens	Minimum number of acceptable results
$2\,500 < A \leq 40\,000$	1	7	7	5
$40\,000 < A \leq 360\,000$	1	7	7	5
$A > 360\,000$	1	3	3	3

Table 3 — Minimum number of test specimens for tiles with a work size thickness $< 7,5$ mm

Maximum area <i>A</i> mm ²	Number of specimens to be tested	Total number of tiles	Total number of specimens	Minimum number of acceptable results
$2\,500 < A \leq 40\,000$	1	7	7	5
$40\,000 < A \leq 360\,000$	1	7	7	5
$A > 360\,000$	3	3	9	8