



# SLOVENSKI STANDARD

## oSIST prEN 12583:2021

01-februar-2021

---

### Infrastruktura za plin - Kompresorske postaje - Funkcionalne zahteve

Gas Infrastructure - Compressor stations - Functional requirements

Gasinfrastruktur - Verdichterstationen - Funktionale Anforderungen

Infrastructures gazières - Stations de compression - Prescriptions fonctionnelles

Ta slovenski standard je istoveten z: prEN 12583

[oSIST prEN 12583:2021](https://standards.iteh.ai/catalog/standards/sist/260a6460-cfe7-42d2-b80e-0b34fa1ce57c/osist-pren-12583-2021)

<https://standards.iteh.ai/catalog/standards/sist/260a6460-cfe7-42d2-b80e-0b34fa1ce57c/osist-pren-12583-2021>

#### ICS:

23.140	Kompresorji in pnevmatični stroji	Compressors and pneumatic machines
75.200	Oprema za skladiščenje nafte, naftnih proizvodov in zemeljskega plina	Petroleum products and natural gas handling equipment

oSIST prEN 12583:2021

en,fr,de

**iTeh STANDARD PREVIEW**  
**(standards.iteh.ai)**

[oSIST prEN 12583:2021](https://standards.iteh.ai/catalog/standards/sist/260a6460-efe7-42d2-b80e-0b34fa1ce57c/osist-pren-12583-2021)

<https://standards.iteh.ai/catalog/standards/sist/260a6460-efe7-42d2-b80e-0b34fa1ce57c/osist-pren-12583-2021>

EUROPEAN STANDARD  
NORME EUROPÉENNE  
EUROPÄISCHE NORM

**DRAFT**  
**prEN 12583**

February 2021

ICS 23.140; 75.200

Will supersede EN 12583:2014

English Version

## Gas Infrastructure - Compressor stations - Functional requirements

Infrastructures gazières - Stations de compression -  
Prescriptions fonctionnelles

Gasinfrastruktur - Verdichterstationen - Funktionale  
Anforderungen

This draft European Standard is submitted to CEN members for enquiry. It has been drawn up by the Technical Committee CEN/TC 234.

If this draft becomes a European Standard, CEN members are bound to comply with the CEN/CENELEC Internal Regulations which stipulate the conditions for giving this European Standard the status of a national standard without any alteration.

This draft European Standard was established by CEN in three official versions (English, French, German). A version in any other language made by translation under the responsibility of a CEN member into its own language and notified to the CEN-CENELEC Management Centre has the same status as the official versions.

CEN members are the national standards bodies of Austria, Belgium, Bulgaria, Croatia, Cyprus, Czech Republic, Denmark, Estonia, Finland, France, Germany, Greece, Hungary, Iceland, Ireland, Italy, Latvia, Lithuania, Luxembourg, Malta, Netherlands, Norway, Poland, Portugal, Republic of North Macedonia, Romania, Serbia, Slovakia, Slovenia, Spain, Sweden, Switzerland, Turkey and United Kingdom.

[https://standards.iteh.ai/catalog/standards/sist/260a6460-efe7-42d2-b80e-](https://standards.iteh.ai/catalog/standards/sist/260a6460-efe7-42d2-b80e-0b3461ee57c/osist-pr-en-12583-2021)

Recipients of this draft are invited to submit, with their comments, notification of any relevant patent rights of which they are aware and to provide supporting documentation.

**Warning** : This document is not a European Standard. It is distributed for review and comments. It is subject to change without notice and shall not be referred to as a European Standard.



EUROPEAN COMMITTEE FOR STANDARDIZATION  
COMITÉ EUROPÉEN DE NORMALISATION  
EUROPÄISCHES KOMITEE FÜR NORMUNG

**CEN-CENELEC Management Centre: Rue de la Science 23, B-1040 Brussels**

## Contents

	Page
European foreword .....	5
<b>1 Scope</b> .....	<b>7</b>
<b>2 Normative references</b> .....	<b>8</b>
<b>3 Terms and definitions</b> .....	<b>10</b>
<b>4 Safety</b> .....	<b>16</b>
<b>5 Asset management and quality assurance</b> .....	<b>16</b>
<b>6 Environmental constraints</b> .....	<b>16</b>
6.1 General.....	16
6.2 NOx and CO determination .....	17
6.2.1 General.....	17
6.2.2 Periodic measurements.....	17
6.2.3 Continuous Emission Monitoring System (CEMS).....	17
6.2.4 Predictive Emission Monitoring System (PEMS).....	17
6.3 Methane emission management.....	18
6.3.1 General.....	18
6.3.2 Design phase.....	18
6.3.3 Construction, commissioning and decommissioning .....	19
6.3.4 Operation and maintenance .....	19
<b>7 Design, construction</b> .....	<b>19</b>
7.1 <b>General requirements for design</b> .....	<b>19</b>
7.1.1 General.....	19
7.1.2 Safety and the environment .....	20
7.2 Location and station lay-out .....	20
7.2.1 Location.....	20
7.2.2 Station lay-out.....	21
7.3 Pipework.....	23
7.3.1 Design considerations.....	23
7.3.2 Valves .....	23
7.3.3 Gas cleaning .....	23
7.3.4 Gas coolers.....	23
7.3.5 Pressure reduction stations.....	23
7.3.6 Recycle line .....	23
7.3.7 Vent systems.....	24
7.3.8 Station isolation system .....	24
7.3.9 Corrosion protection .....	24
7.3.10 Services pipework .....	24
7.3.11 Standard colour code.....	24
7.4 Compressor unit.....	25
7.4.1 General.....	25
7.4.2 Driver .....	25
7.4.3 Compressor .....	26
7.4.4 Unit Control System (UCS) .....	27
7.4.5 Unit auxiliary equipment.....	31
7.4.6 Foundations .....	35
7.4.7 Compressor unit housing.....	35

7.5	Station control and automation .....	35
7.5.1	Station Control System (SCS) .....	35
7.5.2	Station emergency shutdown systems.....	36
7.5.3	Gas detection system.....	36
7.5.4	Fire protection system.....	36
7.5.5	Station valve control and supervision .....	36
7.5.6	Over-pressure protection system.....	37
7.5.7	Over-temperature protection system .....	37
7.6	Electrical installation and power supply .....	37
7.6.1	General .....	37
7.6.2	Electrical power supply.....	38
7.6.3	Electrical installation .....	38
7.6.4	Illumination requirements .....	38
7.7	General requirements for construction .....	38
7.7.1	General .....	38
7.7.2	Execution of work.....	38
7.7.3	Station pipework construction.....	38
8	Testing, commissioning and acceptance.....	39
8.1	General requirements.....	39
8.2	Pre-commissioning .....	39
8.3	Commissioning .....	39
8.4	As built records of the station.....	40
8.5	Handover .....	40
8.6	Responsibility for safety .....	40
9	Operation.....	40
9.1	Introduction and basic requirements.....	40
9.2	Operating organization .....	41
9.3	Instruction procedures.....	41
9.3.1	General .....	41
9.3.2	Instructions for normal situations .....	41
9.3.3	Instructions for failure or emergency situations.....	41
9.3.4	Procedures for specific planned situations.....	42
9.4	Management of operating procedures.....	42
9.5	Training of personnel .....	43
9.6	Safety precautions.....	43
9.6.1	Prevention of gas explosion and fire .....	43
9.6.2	Storage of combustible materials .....	43
9.6.3	Venting.....	43
9.6.4	IT-Security.....	43
10	Maintenance .....	44
10.1	Introduction and basic requirements .....	44
10.2	Maintenance organization.....	44
10.3	Maintenance procedures .....	44
10.3.1	General .....	44
10.3.2	Gas compressor units .....	45
10.3.3	Pipework.....	45
10.4	Management of the maintenance procedures.....	45
10.5	Training of personnel .....	45
10.6	Maintenance tools and equipment.....	46
10.7	Safety.....	46
10.7.1	General .....	46
10.7.2	Safety precautions.....	46

## prEN 12583:2021 (E)

10.7.3 Safety devices .....	47
11 Decommissioning and disposal .....	47
11.1 Decommissioning .....	47
11.2 Disposal .....	47
Annex A (informative) Boundary of a gas compressor station.....	48
Annex B (informative) Parts of a gas compressor unit.....	50
Annex C (informative) Boundary Gas compressor unit — Driver package .....	51
Annex D (informative) Boundary Gas compressor unit — Gas compressor .....	52
Annex E (informative) Boundary Gas compressor unit — Unit control system.....	53
Annex F (informative) Boundary Gas compressor unit — Auxiliary equipment.....	54
Annex G (informative) Significant technical changes between this document and the previous edition .....	55
Annex H (normative) Applicable measurement systems for NO <sub>x</sub> and CO determination.....	56
Annex I (informative) Examples of PEMS and quality insurance applications.....	58
I.1 Predictive Emission Monitoring System (PEMS), a relational model: quality criteria implementation:.....	58
I.1.1 General.....	58
I.1.2 QAL 1, design part.....	58
I.1.3 QAL 2 calibration and functional test (installation) .....	59
I.1.4 QAL 3, drift and precision control in operation.....	59
I.1.5 AST Annual Survey Test.....	59
I.2 An example of a polynomial model for PEMS for gas fired conventional turbines / engines:.....	60
Annex J (informative) Categories of methane emissions .....	61
Bibliography .....	62

## European foreword

This document (prEN 12583:2021) has been prepared by Technical Committee CEN/TC 234 “Gas Infrastructure”, the secretariat of which is held by DIN.

This document is currently submitted to the CEN Enquiry.

This document will supersede EN 12583:2014.

In comparison with the previous edition, the following technical modifications have been made:

- Addition of requirements for hydrogen readiness
- Addition of Methane Emissions Management
- Addition of NO<sub>x</sub> and CO determination
- Addition of references to new European Standards, for example the merging of EN 16348 and EN 15399 (WI 00234093)
- Updated normative references
- Updated with practical experience from the application of the previous edition
- Clarification of technical wording

A detailed overview of all changes is given in Annex G.

This document has been prepared under a mandate given to CEN by the European Commission and the European Free Trade Association.

There is a complete suite of functional standards prepared by CEN/TC 234 “Gas infrastructure” to cover all parts of the gas infrastructure from the input of gas into the on-shore transmission network up to the inlet connection of gas appliances, including transmission, distribution, storage, compression, pressure regulation and metering, installation, injection of non-conventional gases, gas quality issues and others. In preparing this document a basic understanding of gas infrastructure by the user has been assumed.

The gas infrastructure is complex and the importance on safety of its construction and use has led to the development of very detailed codes of practice and operating manuals in the member countries. These detailed statements embrace recognized standards of gas engineering and the specific requirements imposed by the legal structures of the member countries.

Directive 2009/73/EC concerning common rules for the internal market in natural gas and the related Regulation (EC) No 715/2009 on conditions for access to the natural gas transmission networks also aim at technical safety (security) including technical reliability of the European gas system. These aspects are also in the scope of CEN/TC 234 standardization. In this respect CEN/TC 234 evaluated the indicated EU legislation and amended this document accordingly, where required and appropriate.

In this edition of EN 12583 environmental aspects relevant to the design, construction and testing, operation and maintenance, decommissioning and disposal of compressor stations in the scope of this document are covered in accordance with CEN Guide 4 and CEN/TR 16388.

**prEN 12583:2021 (E)**

Directive 2009/28/EC on the promotion of the use of energy from renewable sources and amending and subsequently repealing Directives 2001/77/EC and 2003/30/EC, in Article 3 and 5 are with regard to the calculation of the share of energy from renewable sources and the contribution of hydrogen originating from renewable sources in the total fuel mix. In this respect CEN/TC 234 evaluated the indicated EU legislation and amended this document.

## **iTeh STANDARD PREVIEW (standards.iteh.ai)**

[oSIST prEN 12583:2021](https://standards.iteh.ai/catalog/standards/sist/260a6460-efe7-42d2-b80e-0b34fa1ce57c/osist-pren-12583-2021)

<https://standards.iteh.ai/catalog/standards/sist/260a6460-efe7-42d2-b80e-0b34fa1ce57c/osist-pren-12583-2021>



## 1 Scope

This document describes the specific functional requirements for the design, construction, operation, maintenance and disposal activities for safe and secure gas compressor stations.

This document applies to new gas compressor stations with a Maximum Operating Pressure (MOP) over 16 bar and with a total shaft power over 1 MW. For existing compressor stations, this document applies to new compressor units. Where changes/modifications to existing installations or gas composition take place, due account may be taken of the requirements of this document.

This document does not apply to gas compressor stations operating prior to the publication of this document.

The purpose of this document is intended to:

- ensure the health and safety of the public and all site personnel,
- to cover environmental issues,
- to avoid incidental damage to nearby property, and
- to open the gas infrastructure to accommodate renewable gases, including a possible design for 100 % hydrogen.

This document specifies common basic principles for the gas infrastructure. Users of this document are expected to be aware that more detailed national standards and/or codes of practice can exist in the CEN member countries.

This document is intended to be applied in association with these national standards and/or codes of practice setting out the above-mentioned basic principles.

In the event of conflicts in terms of more restrictive requirements in national legislation/regulation with the requirements of this document, the national legislation/regulation takes precedence as illustrated in CEN/TR 13737 (all parts). CEN/TR 13737 (all parts) gives:

- clarification of all legislations/regulations applicable in a member state;
- if appropriate, more restrictive national requirements;
- a national contact point for the latest information.

This document does not apply to:

- off-shore gas compressor stations;
- gas compressor stations for compressed gas filling-stations;
- customer installations downstream of the point of custody transfer;
- design and construction of driver packages (see Annex C);
- mobile compressor equipment.

For supplies to utility services such as small central heating boilers reference is made to EN 1775.

Figure 1 shows a schematic representation of compressor stations in a gas infrastructure. For further information refer to Annexes A, B, C, D, E and F.

## prEN 12583:2021 (E)

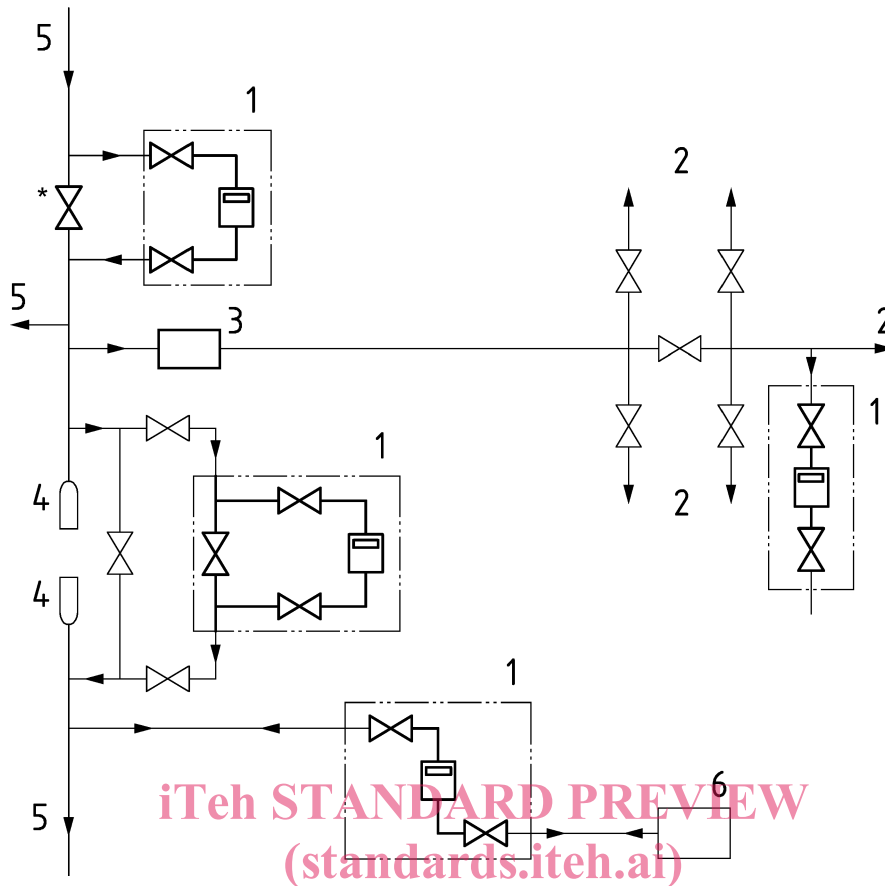

## Key

- 1 compressor station  
 2 distribution system  
 3 metering and/or pressure limiting or regulation station  
 \* part of pipeline but operated by safety control systems  
 4 pig traps  
 5 transmission line  
 6 storage facility

NOTE Parts indicated in frames by thick lines are within the scope of this document.

**Figure 1 — Schematic representation of compressor stations in the gas infrastructure**

## 2 Normative references

The following documents are referred to in the text in such a way that some or all of their content constitutes requirements of this document. For dated references, only the edition cited applies. For undated references, the latest edition of the referenced document (including any amendments) applies.

EN 1012-3, *Compressors and vacuum pumps - Safety requirements - Part 3: Process compressors*

EN 1594, *Gas infrastructure - Pipelines for maximum operating pressure over 16 bar - Functional requirements*

EN 12186, *Gas infrastructure - Gas pressure regulating stations for transmission and distribution - Functional requirements*

EN 12266-1, *Industrial valves - Testing of metallic valves - Part 1: Pressure tests, test procedures and acceptance criteria - Mandatory requirements*

EN 12266-2, *Industrial valves - Testing of metallic valves - Part 2: Tests, test procedures and acceptance criteria - Supplementary requirements*

EN 12732, *Gas infrastructure — Welding steel pipework — Functional requirements*

EN 14505, *Cathodic protection of complex structures*

EN 60079-10-1:2015, *Explosive atmospheres — Part 10-1: Classification of areas — Explosive gas atmospheres (IEC 60079-10-1)*

EN 60079-20-1, *Explosive atmospheres — Part 20-1: Material characteristics for gas and vapour classification — Test methods and data (IEC 60079-20-1)*

EN 61000-6-2, *Electromagnetic compatibility (EMC) - Part 6-2: Generic standards - Immunity for industrial environments (IEC 61000-6-2)*

EN 61000-6-4, *Electromagnetic compatibility (EMC) - Part 6-4: Generic standards - Emission standard for industrial environments (IEC 61000-6-4)*

EN 61508 (all parts), *Functional safety of electrical/electronic/programmable electronic safety-related systems (IEC 61508 (all parts))*

EN 61511 (all parts), *Functional safety — Safety instrumented systems for the process industry sector (IEC 61511 (all parts))*

EN ISO 10437, *Petroleum, petrochemical and natural gas industries - Steam turbines - Special-purpose applications (ISO 10437)*

EN ISO 10439 (all parts), *Petroleum, chemical and gas service industries — Centrifugal compressors (ISO 10439)*

EN ISO 13849-1, *Safety of machinery - Safety-related parts of control systems - Part 1: General principles for design (ISO 13849-1)*

EN ISO/IEC 27001, *Information technology - Security techniques - Information security management systems - Requirements*

ISO 3977-1, *Gas turbines — Procurement — Part 1: General introduction and definitions*

ISO 3977-2, *Gas turbines — Procurement — Part 2: Standard reference conditions and ratings*

ISO 13707, *Petroleum and natural gas industries — Reciprocating compressors*

**prEN 12583:2021 (E)****3 Terms and definitions**

For the purposes of this document, the following terms and definitions apply.

ISO and IEC maintain terminological databases for use in standardization at the following addresses:

- IEC Electropedia: available at <http://www.electropedia.org/>
- ISO Online browsing platform: available at <https://www.iso.org/obp>

**3.1  
alarm**

signal provided to an operator which indicates the approach or the presence of an unwanted event

**3.2  
availability**

ability to be in a state to perform as and when required under given, assuming that the required external resources are provided

Note 1 to entry: This ability depends on the combined aspects of the reliability, the maintainability and recoverability of the item and the maintenance supportability.

Note 2 to entry: Required external resources, other than maintenance resources, do not affect the availability of the item although the item may not be available from the user's viewpoint.

**3.3  
commissioning**

activities required to fill pipework, equipment and assemblies with gas for the first time and to perform test runs to check the system's integrity

**iTeh STANDARD PREVIEW**  
**(standards.iteh.ai)**

[oSIST prEN 12583:2021](https://standards.iteh.ai/catalog/standards/sist/260a6460-efe7-42d2-b80e-0b34fa1ce57c/osist-pren-12583-2021)

<https://standards.iteh.ai/catalog/standards/sist/260a6460-efe7-42d2-b80e-0b34fa1ce57c/osist-pren-12583-2021>

**3.4  
compressor surge**

flow and/or pressure instability including reverse flow inside a compressor

**3.5  
compressor unit**

set of driver package, gas compressor, control system and their auxiliary equipment which includes unit valves and associated pipework to compress gas

Note 1 to entry: Boundary compressor unit / compressor, see Annex D.

**3.6  
compressor unit building**

structure where one or more drivers with compressors and auxiliary equipment are installed

Note 1 to entry: Operation and maintenance are normally carried out inside the building.

Note 2 to entry: Temporary partitions could be installed to isolate a compressor unit during maintenance (see Figure 2).

**3.7  
compressor unit housing**

structure to contain the compressor unit which can consist of compressor unit building, enclosure or a combination of both

**3.8****control room**

room housing the control system from which the station personnel can, when necessary, take action on the process

**3.9****decommissioning**

activities required to take out of service any pipework, stations, equipment or assemblies filled with gas and to disconnect them from the system

**3.10****design pressure**

DP

pressure on which design calculations are based

**3.11****design temperature**

DT

temperature on which design calculations are based

**3.12****disposal**

activities to be performed after components of a decommissioned gas compressor station have been dismantled

**3.13****emergency**

situation which could affect the safe operation of the gas infrastructure and/or the safety of the surrounding area, requiring urgent action

**3.14****emergency shutdown**

ESD

actions, in the event of an emergency, to bring the station and/or the compressor unit(s) into a safe condition which requires local manual resetting

iTeh STANDARD PREVIEW  
(standards.iteh.ai)

oSIST prEN 12583:2021  
<https://standards.iteh.ai/catalog/standards/sist/260a6460-efe7-42d2-b80e-0b34fa1ce57c/osist-pren-12583-2021>

prEN 12583:2021 (E)

3.15 enclosure

structure (a close framework) to surround a driver and/or a compressor and some of their auxiliary equipment in order to protect them from outside influence and avoid possible hazards to personnel

Note 1 to entry: Enclosures could be installed inside the compressor unit building to confine part of a compressor unit (see Figure 2).

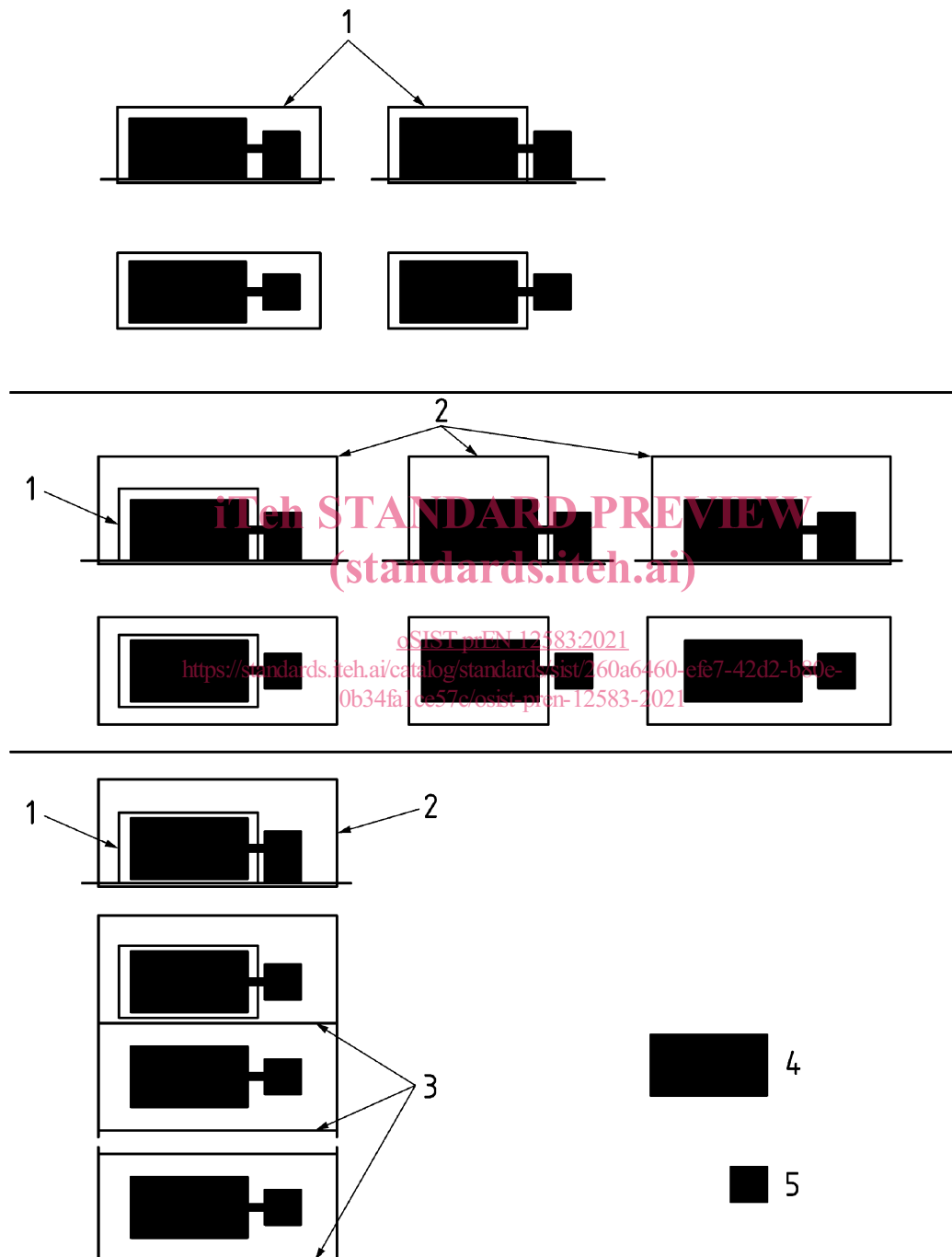

Key

- |                                 |              |
|---------------------------------|--------------|
| 1 enclosure                     | 4 driver     |
| 2 building                      | 5 compressor |
| 3 walls or temporary partitions |              |

Figure 2 — Compressor unit housing

**3.16****fail-safe system**

system where loss of power or actuating fluid to any control element, for example an individual relay, valve, actuator, etc. or any failure of these to operate when energized, leads to a safe condition

Note 1 to entry: In particular, all fault shut-down systems operate by de-energizing and not energizing components.

**3.17****fuel gas system**

system which conditions the fuel gas prior to it entering a gas turbine or gas engine driver package

Note 1 to entry: It can consist of gas filtration, scrubbing, heating, pressure regulating, metering and compression.

**3.18****gas**

gaseous fuel which is in gaseous state at a temperature of 15 °C under atmospheric pressure (1,013 25 bar absolute)

**3.19****gas compressor station**

installation used for:

- transporting gas in pipelines;
- compressing gas from a pipeline to a gas storage facility or vice versa

Note 1 to entry: More than one of the above functions could be performed simultaneously or alternately.

**3.20****gas infrastructure**

pipeline system including pipework and associated stations or plants for the transmission and distribution of gas

**3.21****hazardous area**

area in which an explosive gas atmosphere is or may be expected to be present, in quantities such as to require special precautions for the construction, installation and use of equipment

[SOURCE: EN 60079-10-1:2015]

**3.22****incident**

unexpected occurrence which could lead to an emergency situation

**3.23****isolation valve**

valve which permits isolation of a part or the complete gas compressor station

**3.24****maximum incidental pressure**

MIP

maximum pressure which a gas system can experience during a short time, limited by the safety devices