

---

**Signalizacija po nizkonapetostnih električnih napeljavah v frekvenčnem območju od 3 kHz do 148,5 kHz - 4-4. del: Nizkonapetostni ločilni filtri - Impedančni filter**

Signalling on low-voltage electrical installations in the frequency range 3 kHz to 148,5 kHz Part 4-4: Low voltage decoupling filter - Impedance filter

Signalübertragung auf elektrischen Niederspannungsnetzen im Frequenzbereich 3 kHz bis 148,5 kHz Teil 4-4: Niederspannungs-Entkopplungsfilter - Impedanzfilter

Transmission de signaux sur les réseaux électriques basse tension dans la bande de fréquences de 3 kHz à 148,5 kHz - Partie 4-4: Filtres de découplage basse tension - Filtre d'impédance

**Ta slovenski standard je istoveten z: EN 50065-4-4:2023**

---

**ICS:**

31.160	Električni filtri	Electric filters
33.040.30	Komutacijski in signalizacijski sistem	Switching and signalling systems

**SIST EN 50065-4-4:2023**

**en**



EUROPEAN STANDARD

**EN 50065-4-4**

NORME EUROPÉENNE

EUROPÄISCHE NORM

March 2023

ICS 31.160; 33.040.30; 97.120

Supersedes EN 50065-4-4:2003

English Version

## Signalling on low-voltage electrical installations in the frequency range 3 kHz to 148,5 kHz Part 4-4: Low voltage decoupling filter - Impedance filter

Transmission de signaux sur les réseaux électriques basse tension dans la bande de fréquences de 3 kHz à 148,5 kHz  
- Partie 4-4: Filtres de découplage basse tension - Filtre d'impédance

Signalübertragung auf elektrischen Niederspannungsnetzen im Frequenzbereich 3 kHz bis 148,5 kHz Teil 4-4: Niederspannungs-Entkopplungsfilter - Impedanzfilter

This European Standard was approved by CENELEC on 2022-10-03. CENELEC members are bound to comply with the CEN/CENELEC Internal Regulations which stipulate the conditions for giving this European Standard the status of a national standard without any alteration.

Up-to-date lists and bibliographical references concerning such national standards may be obtained on application to the CEN-CENELEC Management Centre or to any CENELEC member.

This European Standard exists in three official versions (English, French, German). A version in any other language made by translation under the responsibility of a CENELEC member into its own language and notified to the CEN-CENELEC Management Centre has the same status as the official versions.

CENELEC members are the national electrotechnical committees of Austria, Belgium, Bulgaria, Croatia, Cyprus, the Czech Republic, Denmark, Estonia, Finland, France, Germany, Greece, Hungary, Iceland, Ireland, Italy, Latvia, Lithuania, Luxembourg, Malta, the Netherlands, Norway, Poland, Portugal, Republic of North Macedonia, Romania, Serbia, Slovakia, Slovenia, Spain, Sweden, Switzerland, Türkiye and the United Kingdom.



European Committee for Electrotechnical Standardization  
Comité Européen de Normalisation Electrotechnique  
Europäisches Komitee für Elektrotechnische Normung

**CEN-CENELEC Management Centre: Rue de la Science 23, B-1040 Brussels**

EN 50065-4-4:2023 (E)

Contents	Page
European foreword.....	3
1 Scope.....	4
2 Normative references.....	4
3 Terms and definitions .....	5
4 Impedance filter electrical characteristics.....	5
4.1 General.....	5
4.2 Terminations .....	5
4.3 Immunity for EMC .....	5
4.4 Operating frequency range.....	5
4.5 Impedance .....	6
4.6 Transfer function .....	6
4.7 Safety .....	6

**iTeh STANDARD PREVIEW**  
(standards.iteh.ai)

[SIST EN 50065-4-4:2023](https://standards.iteh.ai/catalog/standards/sist/16b877cd-825a-4042-85f7-6229d60eebaf/sist-en-50065-4-4-2023)

<https://standards.iteh.ai/catalog/standards/sist/16b877cd-825a-4042-85f7-6229d60eebaf/sist-en-50065-4-4-2023>

## European foreword

This document (EN 50065-4-4:2023) has been prepared by WG 12 “Filters” of CLC/TC 219 “Mains communicating systems”.

The following dates are fixed:

- latest date by which this document has to be implemented at national level by publication of an identical national standard or by endorsement (dop) 2023-09-24
- latest date by which the national standards conflicting with this document have to be withdrawn (dow) 2026-03-24

This document supersedes EN 50065-4-4:2003 and all of its amendments and corrigenda (if any).

Attention is drawn to the possibility that some of the elements of this document may be the subject of patent rights. CENELEC shall not be held responsible for identifying any or all such patent rights.

EN 50065 consists of the following parts, under the general title: Signalling on low-voltage electrical installations in the frequency range 3 kHz to 148,5 kHz:

Part 1: General requirements, frequency bands and electromagnetic disturbances

Part 2-1: Immunity requirements for mains communications equipment and systems operating in the range of frequencies 95 kHz to 148,5 kHz and intended for use in residential, commercial and light industrial environments

Part 2-2: Immunity requirements for mains communications equipment and systems operating in the range of frequencies 95 kHz to 148,5 kHz and intended for use in industrial environments

Part 2-3: Immunity requirements for mains communications equipment and systems operating in the range of frequencies 3 kHz to 95 kHz and intended for use by electricity suppliers and distributors

Part 4-1: Low voltage decoupling filters – Generic specification

Part 4-2: Low voltage decoupling filters – Safety requirements

Part 4-3: Low voltage decoupling filters – Incoming filter

Part 4-4: Low voltage decoupling filters – Impedance filter

Part 4-5: Low voltage decoupling filters – Segmentation filter

Part 4-6: Low voltage decoupling filters – Phase coupler

Part 4-7: Portable low voltage decoupling filters – Safety requirements

Part 7: Equipment impedance

This document has been prepared under a Standardization Request given to CENELEC by the European Commission and the European Free Trade Association.

Any feedback and questions on this document should be directed to the users' national committee. A complete listing of these bodies can be found on the CENELEC website.

## EN 50065-4-4:2023 (E)

## 1 Scope

This document applies to impedance filters in a mains communication system, intended for utility networks or household and similar fixed installation including residential, commercial and light industrial buildings.

These filters are used to set a suitable impedance, in the nominal frequency range of the mains signalling system, at any point of the low voltage mains network where a low impedance equipment is connected, as shown in Figure 1, in order to allow reliable operation of the mains signalling system.

Impedance filters can be used either in utility or consumer networks. They can also be used in conjunction with incoming filters and segmentation filters.

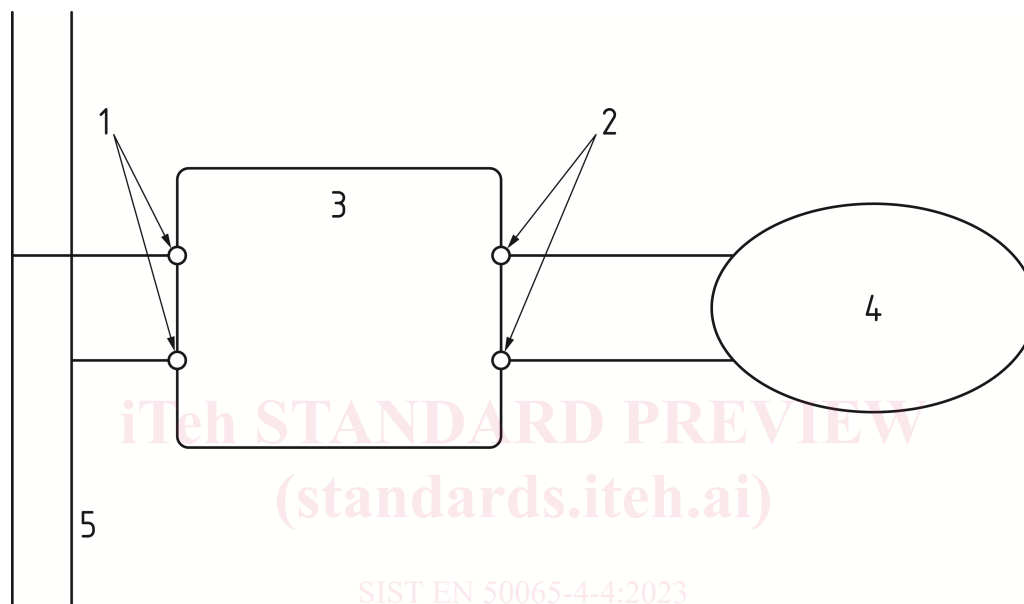

### Key

- |   |                         |
|---|-------------------------|
| 1 | network terminals       |
| 2 | equipment terminals     |
| 3 | impedance filter        |
| 4 | low impedance equipment |
| 5 | low voltage network     |

**Figure 1 — The application of impedance filters**

## 2 Normative references

The following documents are referred to in the text in such a way that some or all of their content constitutes requirements of this document. For dated references, only the edition cited applies. For undated references, the latest edition of the referenced document (including any amendments) applies.

EN 50065-2-1, *Signalling on low-voltage electrical installations in the frequency range 3 kHz to 148,5 kHz - Part 2-1: Immunity requirements for mains communications equipment and systems operating in the range of frequencies 95 kHz to 148,5 kHz and intended for use in residential, commercial and light industrial environments*

EN 50065-2-2, *Signalling on low-voltage electrical installations in the frequency range 3 kHz to 148,5 kHz - Part 2-2: Immunity requirements for mains communications equipment and systems operating in the range of frequencies 95 kHz to 148,5 kHz and intended for use in industrial environments*

EN 50065-2-3, *Signalling on low-voltage electrical installations in the frequency range 3 kHz to 148,5 kHz - Part 2-3: Immunity requirements for mains communications equipment and systems operating in the range of frequencies 3 kHz to 95 kHz and intended for use by electricity suppliers and distributors*

EN 50065-4-1:2001, *Signalling on low-voltage electrical installations in the frequency range 3 kHz to 148,5 kHz - Part 4-1: Low voltage decoupling filters - Generic specification*

EN 50065-4-2, *Signalling on low-voltage electrical installations in the frequency range 3 kHz to 148,5 kHz and 1,6 MHz to 30 MHz - Part 4-2: Low voltage decoupling filters - Safety requirements*

EN 50065-4-3:2003, *Signalling on low-voltage electrical installations in the frequency range 3 kHz to 148,5 kHz - Part 4-3: Low voltage decoupling filter - Incoming filter*

EN 50065-4-7, *Signalling on low-voltage electrical installations in the frequency range 3 kHz to 148,5 kHz and 1,6 MHz to 30 MHz - Part 4-7: Portable low voltage decoupling filters - Safety requirements*

### 3 Terms and definitions

No terms and definitions are listed in this document.

ISO and IEC maintain terminological databases for use in standardization at the following addresses:

- ISO Online browsing platform: available at <https://www.iso.org/obp>
- IEC Electropedia: available at <https://www.electropedia.org/>

### 4 Impedance filter electrical characteristics

#### 4.1 General

The filter shall meet the requirements given in EN 50065-4-1.

#### 4.2 Terminations

The impedance filter shall have a network port connected to the mains communication network and an equipment port connected to either a low impedance equipment, as shown in Figure 1, or a low impedance network. Implementation of impedance filter may not distinguish both ports when designed symmetrically.

#### 4.3 Immunity for EMC

The filter shall meet the immunity requirements specified in:

- EN 50065-2-1 for consumer side in residential, commercial and light industrial environments,
- EN 50065-2-2 for consumer side in industrial environments,
- EN 50065-2-3 for utility side.

#### 4.4 Operating frequency range

The operating frequency range shall be in the band:

- 3 kHz to 95 kHz for the utility network,
- 95 kHz to 148,5 kHz for the consumer network.