**Fibre-reinforced plastic
composites — Determination
of laminate through-thickness
properties —**

Part 2:

**Determination of the elastic
modulus, the strength and the
Weibull size effects by flexural test of
unidirectional laminate, for carbon-
fibre based systems**

<https://standards.iteh.ai/en/standards/iso/20975-2/2018>

*Composites plastiques renforcés de fibres — Détermination des
propriétés de l'épaisseur traversante d'un composite stratifié —*

*Partie 2: Détermination du module d'élasticité, de la résistance et
des effets de la taille de Weibull par essai en flexion sur un composite
stratifié unidirectionnel, pour systèmes à base de fibres de carbone*



iTeh STANDARD PREVIEW
(standards.iteh.ai)

ISO 20975-2:2018

<https://standards.iteh.ai/catalog/standards/sist/25b1fe95-e15f-4b76-8fe4-51c786d28d40/iso-20975-2-2018>



COPYRIGHT PROTECTED DOCUMENT

© ISO 2018

All rights reserved. Unless otherwise specified, or required in the context of its implementation, no part of this publication may be reproduced or utilized otherwise in any form or by any means, electronic or mechanical, including photocopying, or posting on the internet or an intranet, without prior written permission. Permission can be requested from either ISO at the address below or ISO's member body in the country of the requester.

ISO copyright office
CP 401 • Ch. de Blandonnet 8
CH-1214 Vernier, Geneva
Phone: +41 22 749 01 11
Fax: +41 22 749 09 47
Email: copyright@iso.org
Website: www.iso.org

Published in Switzerland

Contents

	Page
Foreword	iv
Introduction	v
1 Scope	1
2 Normative references	1
3 Terms and definitions	1
4 Principle	2
5 Conditioning	3
5.1 Conditioning of test specimen.....	3
5.2 Temperature and humidity in testing.....	3
6 Apparatus	3
7 Test specimens	4
7.1 Shape and dimensions.....	4
7.2 Preparation of specimens.....	4
7.2.1 General.....	4
7.2.2 Test plate.....	4
7.3 Specimen inspection.....	5
7.4 Number of specimens.....	5
8 Procedure	6
9 Calculations	6
9.1 Through-thickness tensile stress.....	6
9.2 Through-thickness tensile strength.....	7
9.3 Weibull modulus by flexural test.....	7
9.4 Effective volume of flexural specimen.....	7
9.5 Through-thickness tensile strain.....	8
9.6 Through-thickness tensile strain at failure.....	8
9.7 Through-thickness tensile modulus.....	8
9.8 Significant figures of stress and elastic modulus.....	8
9.9 Expression of results.....	9
10 Precision	9
11 Test report	9
Annex A (informative) Precision data obtained from an interlaboratory test	11
Bibliography	13

Foreword

ISO (the International Organization for Standardization) is a worldwide federation of national standards bodies (ISO member bodies). The work of preparing International Standards is normally carried out through ISO technical committees. Each member body interested in a subject for which a technical committee has been established has the right to be represented on that committee. International organizations, governmental and non-governmental, in liaison with ISO, also take part in the work. ISO collaborates closely with the International Electrotechnical Commission (IEC) on all matters of electrotechnical standardization.

The procedures used to develop this document and those intended for its further maintenance are described in the ISO/IEC Directives, Part 1. In particular the different approval criteria needed for the different types of ISO documents should be noted. This document was drafted in accordance with the editorial rules of the ISO/IEC Directives, Part 2 (see www.iso.org/directives).

Attention is drawn to the possibility that some of the elements of this document may be the subject of patent rights. ISO shall not be held responsible for identifying any or all such patent rights. Details of any patent rights identified during the development of the document will be in the Introduction and/or on the ISO list of patent declarations received (see www.iso.org/patents).

Any trade name used in this document is information given for the convenience of users and does not constitute an endorsement.

For an explanation on the voluntary nature of standards, the meaning of ISO specific terms and expressions related to conformity assessment, as well as information about ISO's adherence to the World Trade Organization (WTO) principles in the Technical Barriers to Trade (TBT) see the following URL: www.iso.org/iso/foreword.html (standards.iteh.ai)

This document was prepared by Technical Committee ISO/TC 61, *Plastics*, Subcommittee SC 13, *Composites and reinforcement fibres*.
ISO 20975-2:2018

<https://standards.iteh.ai/catalog/standards/sist/25b1fe95-e15f-4b76-8fe4-51186384476e/iso-20975-2-2018>
A list of all parts in the ISO 20975 series can be found on the ISO website.

Any feedback or questions on this document should be directed to the user's national standards body. A complete listing of these bodies can be found at www.iso.org/members.html.

Introduction

With the increasing number of applications of composite materials, the necessity of a test method for evaluating through-thickness mechanical properties has been recognized. ASTM D6415[1] and ASTM D7291[2] were proposed for evaluating out-of-plane properties. However, ASTM D6415 has no method for evaluating through-thickness tensile modulus because this test method is based on evaluating the curved beam strength of a fibre-reinforced polymer matrix composite laminate panel. Further, the following problems have been reported regarding ASTM D7291[2]; bonding between the specimen and the loading tab is required, the stress distribution in the specimen is not uniform, and a local stress concentration is generated[3],[4]. This means that the fracture load depends on the maximum stress induced at the point of the stress concentration. Therefore, through-thickness strength evaluated by ASTM D7291 cannot be simply compared with other specimens. In addition, it was reported that the apparent out-of-plane modulus evaluated under ASTM D7291 varies with strain gage position, strain gage length, and specimen thickness[5]. This document provides a test method to evaluate the through-thickness mechanical properties of composite materials.

iTeh STANDARD PREVIEW (standards.iteh.ai)

ISO 20975-2:2018

<https://standards.iteh.ai/catalog/standards/sist/25b1fe95-e15f-4b76-8fe4-51c786d28d40/iso-20975-2-2018>

iTeh STANDARD PREVIEW
(standards.iteh.ai)

ISO 20975-2:2018

<https://standards.iteh.ai/catalog/standards/sist/25b1fe95-e15f-4b76-8fe4-51c786d28d40/iso-20975-2-2018>

Fibre-reinforced plastic composites — Determination of laminate through-thickness properties —

Part 2:

Determination of the elastic modulus, the strength and the Weibull size effects by flexural test of unidirectional laminate, for carbon-fibre based systems

1 Scope

This document specifies a flexural test method for determining the through-thickness (out-of-plane) tensile properties of laminated carbon fibre-reinforced plastic (CFRP) composites, including strength, fracture strain, and modulus. This document is applicable to unidirectional CFRP (UD-CFRP) laminates. In addition, the calculation of effective volume is also described due to size effects of the through-thickness tensile strength.

2 Normative references

The following documents are referred to in the text in such a way that some or all of their content constitutes requirements of this document. For dated references, only the edition cited applies. For undated references, the latest edition of the referenced document (including any amendments) applies.

ISO 291, *Plastics — Standard atmospheres for conditioning and testing*

ISO 1268-1, *Fibre-reinforced plastics — Methods of producing test plates — Part 1: General conditions*

ISO 1268-4, *Fibre-reinforced plastics — Methods of producing test plates — Part 4: Moulding of prepregs*

ISO 2818, *Plastics — Preparation of test specimens by machining*

ISO 5893, *Rubber and plastics test equipment — Tensile, flexural and compression types (constant rate of traverse) — Specification*

ISO 20501, *Fine ceramics (advanced ceramics, advanced technical ceramics) — Weibull statistics for strength data*

3 Terms and definitions

For the purposes of this document, the following terms and definitions apply.

ISO and IEC maintain terminological databases for use in standardization at the following addresses:

- ISO Online browsing platform: available at <https://www.iso.org/obp>
- IEC Electropedia: available at <http://www.electropedia.org/>

3.1

span length of flexural test

L

length of span between supports

**3.2
flexural load**

P

load on specimen from loading nose at any given time

**3.3
through-thickness tensile stress**

σ

nominal stress in the outer surface of the flexural test specimen at mid-span

Note 1 to entry: It is calculated according to the relationship given by [Formula \(2\)](#).

**3.4
deflection**

D

distance through which the top or bottom surface of the test specimen at mid-span has deflected during flexure from its original position

**3.5
through-thickness strain**

ε

nominal fractional change in length of an element in the outer surface of the test specimen at mid-span

**3.6
through-thickness tensile strength**

σ_f

maximum through-thickness tensile stress by flexural test or through-thickness stress at failure

**3.7
through-thickness modulus**

E

slope calculated from linear region of through thickness stress-strain curve

**3.8
Weibull modulus of through-thickness strength data**

m

empirical parameter that decides the probability density function of the Weibull distribution

**3.9
effective volume of flexural specimen**

V_{eff}

size of an equivalent uniaxial tensile specimen that has the same probability of rupture as the test specimen

Note 1 to entry: The effective volume is parameter of Weibull size effects of strength. It is calculated from the thickness, the width and the span length of the flexural test, and the Weibull modulus based on beam theory.

4 Principle

A rectangular test specimen, whose longitudinal direction coincides with the through-thickness direction of the CFRP laminate, is positioned between two supports and deflected by means of a loading edge acting on the specimen midway between the supports. The test specimen is deflected at a constant rate until rupture occurs on the outer surface of the specimen. The through-thickness properties are determined by estimating tensile stress and strain generated in the flexural test specimen. Size effects are estimated quantitatively by estimating tensile strength and effective volume due to dependence of strength on size effects.

5 Conditioning

5.1 Conditioning of test specimen

The test specimens shall be conditioned as specified in the standard for the material being tested. In the absence of this information, select the most appropriate conditions from ISO 291, unless otherwise agreed upon by the interested parties, e.g. for testing at high or low temperatures. The preferred set of conditions in ISO 291 is standard atmosphere 23/50, except when the flexural properties of the material are known to be insensitive to moisture, in which case humidity control is unnecessary.

5.2 Temperature and humidity in testing

The test shall be carried out under the conditions specified in 5.1.

6 Apparatus

6.1 Testing machine, which shall conform to ISO 5893 according to the requirements specified in 5.1 and 5.2.

The speed of testing shall be kept constant according to ISO 5893.

6.2 Load and deflection indicators, indicator for the load shall be used, and the error in the indicated force shall be kept to less than 0,1 N.

6.3 Test fixture

The two supports and the central loading edge shall be arranged as shown in Figure 1. The radius of supports and loading nose are $2\text{ mm} \pm 0,2\text{ mm}$ and $5\text{ mm} \pm 0,2\text{ mm}$, respectively (refer to ISO 14125).

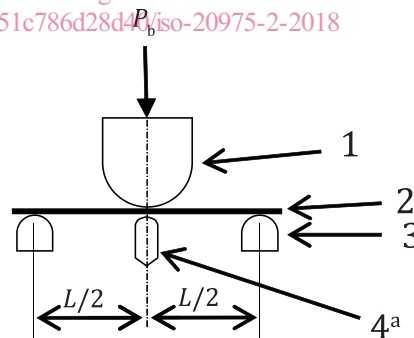

Key

- 1 loading nose
- 2 test specimen
- 3 supports
- 4 displacement transducer
- a See 6.4 for details.

Figure 1 — Example of test fixture and specimen

6.4 Deflection-measuring system: displacement transducer, shall be valid over the entire range of deflections to be measured. Using displacement transducer shall be agreed upon between the interested parties. The force required to operate the displacement transducer shall not exceed 1 % of the force at failure.

6.5 **Data acquisition system**, which shall be able to record the flexural force versus deflection data.

6.6 **Devices for measuring: Micrometer or equivalent**, capable of reading to 0,005 mm or better, and suitable for measuring the width, b , and thickness, t , of the test specimen.

7 Test specimens

7.1 Shape and dimensions

The shape and dimensions of the test specimens shall be according to [Table 1](#).

Table 1 — Dimensions of test specimen

Parameter	mm
Width b	$10 \pm 0,5$
Thickness t	$1,0^{+0,2}_{-0}$
Length l	$>25t + 4$

The span length shall be over 25 times the thickness of the test specimen.

In any test specimen, the thickness within the central third of the length shall not deviate by more than 2 % from the mean value. In addition, the width shall not deviate within this section of the specimen by more than 3 % from the mean value. The shape and dimensions shall be selected from [Table 1](#) or agreed upon between the interested parties under the condition of $L/t > 25$.

7.2 Preparation of specimens

7.2.1 General

ISO 20975-2:2018
<https://standards.iteh.ai/catalog/standards/sist/25b1fe95-e15f-4b76-8fe4-51c786d28d40/iso-20975-2-2018>

Specimens shall be machined from a test plate prepared in accordance with ISO 1268-1 and ISO 1268-4 or another specified or agreed-upon procedure. Specimens shall be machined from plates in accordance with ISO 2818. These operations shall be properly performed to prevent the generation of damage on specimen.

7.2.2 Test plate

[Figure 2](#) shows the UD-CFRP test plate for a test specimen. The in-plane fibre direction, in-plane transverse direction, and thickness direction are defined as 1, 2, and 3, respectively.

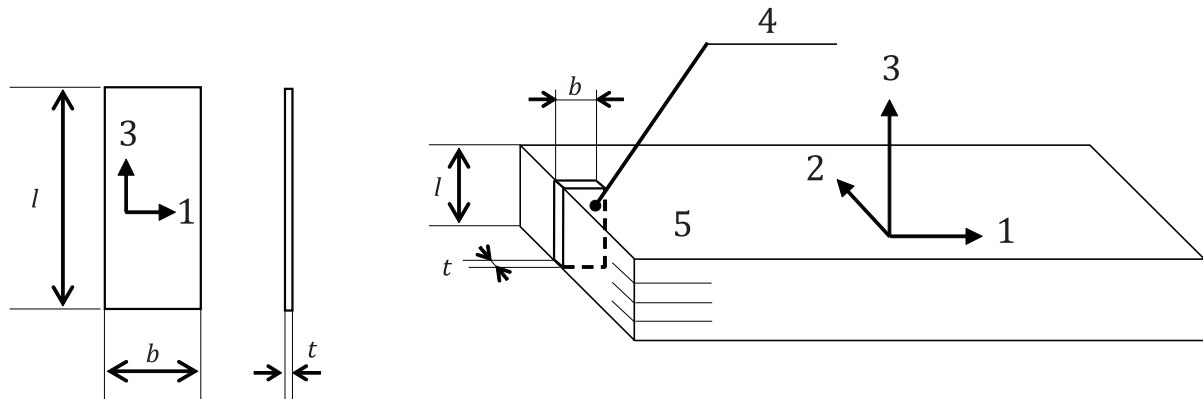

Key

- 1 in-plane fibre direction (width direction of flexural specimen)
- 2 in-plane transverse direction (thickness direction of flexural specimen)
- 3 thickness direction (length direction of flexural specimen)
- 4 specimen
- 5 test plate
- b width of flexural specimen (machined from test plate)
- l length of flexural specimen (machined from test plate)
- t thickness of flexural specimen (machined from test plate)

iTeh STANDARD PREVIEW

Figure 2 — Test plate and test specimen of UD-CFRP
(standards.iteh.ai)

7.3 Specimen inspection ISO 20975-2:2018

<https://standards.iteh.ai/catalog/standards/sist/25b1fe95-e15f-4b76-8fe4-51c6d15847d3-iso-20975-2-2018>

The specimens shall be free of twist and preferably have mutually perpendicular surfaces. All surfaces and edges shall be free of sink marks, scratches, pits and flash. The specimens shall be checked for conformity with these requirements by visual observation against a straight edge, square, or flat plate and by measurement with micrometre callipers. Specimens showing measurable or observable departure from one or more of these requirements shall be rejected before testing.

7.4 Number of specimens

If the estimated effective volume and Weibull modulus is not required, a minimum of five specimens shall be tested. If the estimated effective volume and Weibull modulus are required then a minimum of 30 specimens shall be tested.