

Third edition
2018-09

Corrected version
2021-03

Passenger car tyres — Spare unit substitutive equipment (SUSE)

*Pneumatiques pour voitures particulières — Équipements de
substitution de roue de secours (SUSE)*

iTeh STANDARD PREVIEW
(standards.iteh.ai)

[ISO 16992:2018](https://standards.iteh.ai/catalog/standards/sist/f7838379-7a03-4df5-8fd2-d4df48abfd63/iso-16992-2018)

[https://standards.iteh.ai/catalog/standards/sist/f7838379-7a03-4df5-8fd2-
d4df48abfd63/iso-16992-2018](https://standards.iteh.ai/catalog/standards/sist/f7838379-7a03-4df5-8fd2-d4df48abfd63/iso-16992-2018)



Reference number
ISO 16992:2018(E)

© ISO 2018

iTeh STANDARD PREVIEW
(standards.iteh.ai)

[ISO 16992:2018](https://standards.iteh.ai/catalog/standards/sist/f7838379-7a03-4df5-8fd2-d4df48abfd63/iso-16992-2018)

<https://standards.iteh.ai/catalog/standards/sist/f7838379-7a03-4df5-8fd2-d4df48abfd63/iso-16992-2018>



COPYRIGHT PROTECTED DOCUMENT

© ISO 2018

All rights reserved. Unless otherwise specified, or required in the context of its implementation, no part of this publication may be reproduced or utilized otherwise in any form or by any means, electronic or mechanical, including photocopying, or posting on the internet or an intranet, without prior written permission. Permission can be requested from either ISO at the address below or ISO's member body in the country of the requester.

ISO copyright office
CP 401 • Ch. de Blandonnet 8
CH-1214 Vernier, Geneva
Phone: +41 22 749 01 11
Email: copyright@iso.org
Website: www.iso.org

Published in Switzerland

Contents

	Page
Foreword	iv
Introduction	v
1 Scope	1
2 Normative references	1
3 Terms and definitions	2
4 Symbols	4
5 Conformance	4
6 SUSE systems	4
6.1 General.....	4
6.2 Function and performance.....	4
7 Endurance test	8
7.1 Endurance test for a run-flat tyre, or a self-supporting tyre, or a tyre equipped with the internal supporting ring.....	8
7.2 Endurance test for an extended mobility tyre.....	10
8 Markings	10
Annex A (informative) Properties of a SUSE providing restored mobility	11
Annex B (informative) Properties of a SUSE providing preserved mobility	12
Bibliography	13

ITih STANDARD PREVIEW
(standards.iteh.ai)

ISO 16992:2018

<https://standards.iteh.ai/catalog/standards/sist/f7838379-7a03-4df5-8fd2-d4df48abfd63/iso-16992-2018>

Foreword

ISO (the International Organization for Standardization) is a worldwide federation of national standards bodies (ISO member bodies). The work of preparing International Standards is normally carried out through ISO technical committees. Each member body interested in a subject for which a technical committee has been established has the right to be represented on that committee. International organizations, governmental and non-governmental, in liaison with ISO, also take part in the work. ISO collaborates closely with the International Electrotechnical Commission (IEC) on all matters of electrotechnical standardization.

The procedures used to develop this document and those intended for its further maintenance are described in the ISO/IEC Directives, Part 1. In particular the different approval criteria needed for the different types of ISO documents should be noted. This document was drafted in accordance with the editorial rules of the ISO/IEC Directives, Part 2 (see www.iso.org/directives).

Attention is drawn to the possibility that some of the elements of this document may be the subject of patent rights. ISO shall not be held responsible for identifying any or all such patent rights. Details of any patent rights identified during the development of the document will be in the Introduction and/or on the ISO list of patent declarations received (see www.iso.org/patents).

Any trade name used in this document is information given for the convenience of users and does not constitute an endorsement.

For an explanation on the voluntary nature of standards, the meaning of ISO specific terms and expressions related to conformity assessment, as well as information about ISO's adherence to the World Trade Organization (WTO) principles in the Technical Barriers to Trade (TBT) see the following URL: www.iso.org/iso/foreword.html. (standards.iteh.ai)

This document was prepared by Technical Committee ISO/TC 31, *Tyres, rims and valves*, Subcommittee SC 3, *Passenger car tyres and rims*. ISO 16992:2018

<https://standards.iteh.ai/catalog/standards/sist/f7838379-7a03-4df5-8fd2-34d68a86d121>

This third edition cancels and replaces the second edition (ISO 16992:2010), which has been technically revised through the following significant changes:

- new “extended mobility tyres” definition and pictogram added;
- “extended mobility system” definition renamed “SUSE system”;
- TPMS definition added;
- endurance testing conditions for run-flat tyres better defined with the aim to avoid interpretations while improving the test repeatability;
- new endurance test for extended mobility tyres added;
- Figure 3: symbol for internal support ring amended as per ISO TC 145/SC 3 recommendation to comply with ISO/IEC Directives (SPR letters removed).

This corrected version of ISO 16992:2018 incorporates the following correction: the dimensions of [Figure 2](#) have been corrected.

Introduction

In order to ensure unrestricted mobility, road vehicles should be equipped with fully efficient tyres in all positions.

Road vehicles are therefore traditionally provided with a spare unit intended to reinstate vehicle mobility in the event of loss of efficiency of one tyre. The spare unit can be either of the following:

- of the same type of the units normally equipping the vehicle, or
- of “temporary use” type, thus intended for use only under restricted conditions.

Some vehicles, however, can be constructed and provided with devices that can reinstate their mobility even in the absence of a spare unit on board. Various types of such devices (emergency solutions, products and systems) are available to users in order to ensure that they are able to continue their journey in the event of loss of efficiency of one or more tyres.

The term “spare unit substitutive equipment (SUSE)” (see 3.6) is used as a general name for all equipment intended to replace a spare unit on board the vehicle.

The term “SUSE system” (see 3.7) refers to the assembly of several independent but interacting components specified and approved by a system manager.

This document mainly concerns the SUSE systems for vehicles equipped with passenger car tyres, thus allowing driving to continue in restricted conditions after a loss of efficiency of at least one of the tyres of the vehicle.

This document specifies minimum performance levels for SUSE. It provides guidance when establishing objective requirements for a SUSE and allows the standard level of a given existing SUSE system to be determined.

It is recommended that for any on-road application of run-flat or extended mobility tyres, they be mounted on rims with humps on both inboard and outboard sides.

iTeh STANDARD PREVIEW
(standards.iteh.ai)

ISO 16992:2018

<https://standards.iteh.ai/catalog/standards/sist/f7838379-7a03-4df5-8fd2-d4df48abfd63/iso-16992-2018>

Passenger car tyres — Spare unit substitutive equipment (SUSE)

1 Scope

This document describes spare unit substitutive equipment (SUSE) for passenger car tyres, which is designed to enable users to continue their journey (with or without a stop) in a reasonably safe manner.

NOTE 1 Certain equipment becomes effective automatically, thus avoiding the need to stop the vehicle immediately for inspection and corrective action.

This document is intended only to qualify the performance of SUSE systems. Its specifications only apply to SUSE systems that can permit the extended mobility of the vehicle.

NOTE 2 Other types of SUSE are described in [Annexes A](#) and [B](#).

The specifications in this document apply from the moment the SUSE system becomes effective, with the driver continuing to control the vehicle (in terms of speed and direction) in an attempt to reach an appropriate place for servicing.

The following are within the scope of this document:

- the description of the various types of SUSE;
- the description and performance levels of complete SUSE systems.

NOTE 3 The performance level that the user reasonably has the right to expect, as well as the restrictive conditions placed upon that level, can vary to a large degree depending on the equipment installed and on the real operating conditions of the tyre in flat-tyre running mode.

The following are outside the scope of this document:

- the vehicle to be equipped;
- the tyre while operating in inflated mode;
- the characteristics of the pressure survey device and of the warning function relative to the inflated mode or to the partially deflated mode due to slow pressure losses;
- the transitory phase, if any, before the equipment becomes effective;
- the inspection, assessment, and the servicing of the SUSE system, after it has been activated in flat tyre running mode.

2 Normative references

The following documents are referred to in the text in such a way that some or all of their content constitutes requirements of this document. For dated references, only the edition cited applies. For undated references, the latest edition of the referenced document (including any amendments) applies.

ISO 4000 (all parts), *Passenger car tyres and rims*

ISO 10191, *Passenger car tyres — Verifying tyre capabilities — Laboratory test methods*

3 Terms and definitions

For the purposes of this document, the following terms and definitions apply.

ISO and IEC maintain terminological databases for use in standardization at the following addresses:

- IEC Electropedia: available at <http://www.electropedia.org/>
- ISO Online browsing platform: available at <http://www.iso.org/obp>

3.1 tyre

pneumatic tyre which is a flexible component of the wheel assembly made of rubber and reinforcing materials

Note 1 to entry: Inflating the tyre with compressed gas, as described in 5.1, enables the tyre to carry the wheel load as a part of an axle load and to transmit longitudinal and transversal forces. In the unladen condition, the inflated tyre is essentially toroidal.

3.2 run-flat tyre self supporting tyre SST

tyre structure provided with any technical solutions (for example, reinforced sidewalls, etc.) designed to operate in an inflated mode and allowing the tyre, mounted on the appropriate wheel and in the absence of any supplementary component, to supply the vehicle with the basic tyre functions at a specified speed and distance when operating in flat tyre running mode, able to successfully complete the endurance test as described in 7.1

3.3 extended mobility tyre EMT

tyre featuring on purpose technology designed to operate in an inflated mode and allowing the tyre, mounted on the appropriate wheel and in the absence of any supplementary component, to supply the vehicle with the basic tyre functions at a specified speed and distance when operating in flat tyre running mode, able to successfully complete the endurance test as described in 7.2

3.4 internal support

device, resting on the rim, that helps supply the vehicle with basic tyre functions when operating in flat tyre running mode which allows the tyre to successfully complete the endurance test as described in 7.1

3.5 spare unit

assembly of a tyre and a wheel intended to replace a tyre/wheel assembly already fitted on a vehicle that has lost some functional efficiency

Note 1 to entry: The tyre/wheel assembly can include a tube and a valve, etc.

3.6 spare unit substitutive equipment SUSE

equipment intended to maintain or restore, but not replace, the basic functions of a tyre in the event of a tyre/wheel assembly failure

3.7**SUSE system**

assembly of specified functionally dependent components including, but not limited to, a tyre and a run-flat warning system, which together provide the specified performance granting extended mobility to a vehicle thus, equipped as described in [6.2](#)

Note 1 to entry: This definition was previously titled “extended mobility system” in 16992:2010.

Note 2 to entry: Examples which do not meet this document are shown in [Annexes A](#) and [B](#).

3.8**inflated mode**

normal working state of a tyre, inflated at the cold inflation pressure recommended by the vehicle manufacturer or the tyre manufacturer for the intended service

3.9**loss of tyre functional efficiency**

pressure loss of the tyre/wheel assembly which results in operation in flat tyre running mode and which could be rapid, slow or uncontrolled, leading to a reduction of basic tyre function

3.10**flat tyre running mode**

state of a tyre while operating at an inflation pressure between 0 kPa and 70 kPa

3.11**run-flat warning system****RFWS**

system which delivers information to the driver that a tyre is operating in the flat tyre running mode

Note 1 to entry: In addition, an RFWS can also warn the driver when the expected run-flat potential of the SUSE system has been used.

[ISO 16992:2018](https://standards.iteh.ai/catalog/standards/sist/f7838379-7a03-4df5-8fd2-d4df48abfd63/iso-16992-2018)

<https://standards.iteh.ai/catalog/standards/sist/f7838379-7a03-4df5-8fd2-d4df48abfd63/iso-16992-2018>

3.12**tyre pressure monitoring system****TPMS**

system fitted on a vehicle, able to perform a function to evaluate the inflation pressure of the tyres or the variation of this inflation pressure over time and to transmit corresponding information to the user while the vehicle is running

3.13**significant reduction of the tyre inflation pressure**

event leading a tyre to operate at an inflation pressure insufficient for the intended service on a given vehicle

Note 1 to entry: The intended service comprises the load, speed and camber.

3.14**restored mobility**

operating condition of a vehicle that, following the loss of tyre functional efficiency, is recovered by manual deployment of a SUSE after an immediate stop

3.15**preserved mobility**

operating condition of a vehicle that, following the loss of tyre functional efficiency, is recovered automatically by means of a SUSE

3.16**extended mobility**

operating condition of a vehicle that, following the loss of tyre functional efficiency, is provided by means of a SUSE system

3.17

basic tyre functions

normal capability of an inflated tyre to support a given load up to a given speed and to transmit the driving, the steering and the braking forces to the ground on which it runs

4 Symbols

The ISO 16992 symbols are used to identify those tyres that comply with requirements of this document (see also [Clause 8](#)).

[Figure 1](#) provides the ISO 7000-3620 symbol for a run-flat tyre or self-supporting tyre, where the tyre shape is deleted to avoid technological limitations on legible reproduction when moulded into the sidewall of a tyre.

[Figure 2](#) provides the ISO 7000-3619 symbol for an extended mobility tyre, where the tyre shape is deleted to avoid technological limitations on legible reproduction when moulded into the sidewall of a tyre.

[Figure 3](#) provides the ISO 7000-3621 symbol for an internal support ring.

5 Conformance

5.1 When in inflated mode, and therefore functionally efficient, a tyre that is part of a SUSE shall conform in all respects to the usual criteria of a tyre that can only be used in an inflated state, normal tyre load, i.e. it shall conform to ISO 4000 (all parts) and to ISO 10191, and it shall be similarly maintained.

The user shall therefore continue to comply with all recommendations of the tyre manufacturer, or the vehicle manufacturer, or both, as for a tyre. In particular, the cold inflation pressure of each tyre shall be regularly checked. This check is necessary to ensure that it is at least adequate for the intended service (position, load, speed, camber, etc.) and that it conforms to the specifications of the tyre manufacturer, or the vehicle manufacturer, or both.

5.2 Whichever SUSE is chosen to equip a vehicle, it shall not degrade the service properties of the tyre in inflated mode.

5.3 The performance of a SUSE depends upon the nature of the damage that was the cause of the loss of tyre functional efficiency.

5.4 Depending on the technical characteristics and functionality, a SUSE may offer to the vehicle different degrees of mobility (i.e. restored mobility, preserved mobility or extended mobility).

6 SUSE systems

6.1 General

SUSE systems may be based on either self-supporting tyres, extended mobility tyres or assemblies including an internal support.

6.2 Function and performance

The SUSE system becomes effective automatically in the event of a loss of tyre functional efficiency and the system informs the driver. The driver shall adjust the driving behaviour according to the instructions supplied with the SUSE system. The driver can continue the journey, informed of the flat tyre running mode and aware of the expected performance level. A SUSE system shall be able to operate in flat tyre running mode at a speed of 80 km/h for a distance of 80 km.

SUSE systems shall activate automatically and include a run-flat warning system that warns the driver of the following:

- that the flat tyre running mode has been reached;
- any failure of the run-flat warning system.

At the end of the specified performance of a SUSE system, operating in flat tyre running mode, the loss of mobility shall not be immediate.

Dimensions in millimetres

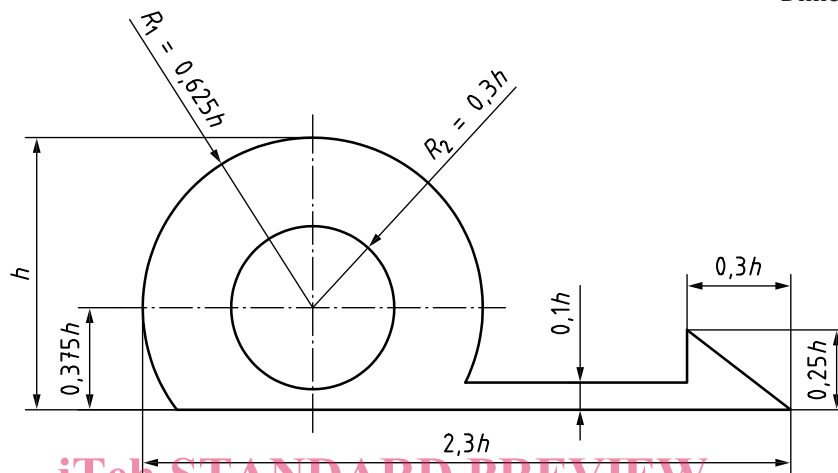

iTeh STANDARD PREVIEW
(standards.iteh.ai)

ISO 16992:2018

<https://standards.iteh.ai/catalog/standards/sist/f7838379-7a03-4df5-8fd2-d4e38abfd63/iso-16992-2018>

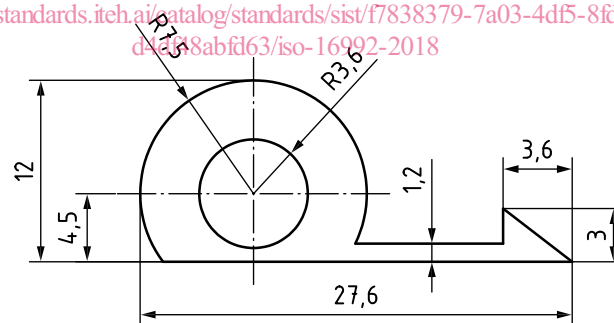

Key

h figure height

R_1, R_2 circle radii

NOTE This figure can be drawn with $h = 12$ mm. Actual symbol size with $h = 12$ mm.

Figure 1 — Self-supporting tyre symbol: ISO 7000-3620 symbol for a run-flat or self-supporting tyre