



SLOVENSKI STANDARD SIST EN 12697-48:2022

01-januar-2022

Bitumenske zmesi - Preskusne metode - 48. del: Zlepljenost plasti

Bituminous mixtures - Test methods - Part 48: Interlayer Bonding

Asphalt - Prüfverfahren - Teil 48: Schichtenverbund

Mélanges bitumineux - Méthodes d'essai - Partie 48: Lien de couches

Ta slovenski standard je istoveten z: EN 12697-48:2021

[SIST EN 12697-48:2022](https://standards.iteh.ai/catalog/standards/sist/86c575da-cd48-43df-b199-aeb70c42fc7f/sist-en-12697-48-2022)

<https://standards.iteh.ai/catalog/standards/sist/86c575da-cd48-43df-b199-aeb70c42fc7f/sist-en-12697-48-2022>

ICS:

93.080.20 Materiali za gradnjo cest Road construction materials

SIST EN 12697-48:2022

en,fr,de

iTeh STANDARD PREVIEW
(standards.iteh.ai)

SIST EN 12697-48:2022

<https://standards.iteh.ai/catalog/standards/sist/86c575da-ed48-43df-b199-aeb70c42fc7f/sist-en-12697-48-2022>

EUROPEAN STANDARD
NORME EUROPÉENNE
EUROPÄISCHE NORM

EN 12697-48

November 2021

ICS 93.080.20

English Version

**Bituminous mixtures - Test methods - Part 48: Interlayer
Bonding**

Mélanges bitumineux - Méthodes d'essai - Partie 48:
Lien de couches

Asphalt - Prüfverfahren - Teil 48: Schichtenverbund

This European Standard was approved by CEN on 16 August 2021.

CEN members are bound to comply with the CEN/CENELEC Internal Regulations which stipulate the conditions for giving this European Standard the status of a national standard without any alteration. Up-to-date lists and bibliographical references concerning such national standards may be obtained on application to the CEN-CENELEC Management Centre or to any CEN member.

This European Standard exists in three official versions (English, French, German). A version in any other language made by translation under the responsibility of a CEN member into its own language and notified to the CEN-CENELEC Management Centre has the same status as the official versions.

CEN members are the national standards bodies of Austria, Belgium, Bulgaria, Croatia, Cyprus, Czech Republic, Denmark, Estonia, Finland, France, Germany, Greece, Hungary, Iceland, Ireland, Italy, Latvia, Lithuania, Luxembourg, Malta, Netherlands, Norway, Poland, Portugal, Republic of North Macedonia, Romania, Serbia, Slovakia, Slovenia, Spain, Sweden, Switzerland, Turkey and United Kingdom.

<https://standards.iteh.ai/catalog/standards/sist/86c575da-ed48-43df-b199-aeb70c42fc7f/sist-en-12697-48-2022>



EUROPEAN COMMITTEE FOR STANDARDIZATION
COMITÉ EUROPÉEN DE NORMALISATION
EUROPÄISCHES KOMITEE FÜR NORMUNG

CEN-CENELEC Management Centre: Rue de la Science 23, B-1040 Brussels

Contents	Page
European foreword.....	3
1 Scope	4
2 Normative references	4
3 Terms and definitions	4
4 Principle	5
4.1 General.....	5
4.2 Torque Bond Test (TBT).....	5
4.3 Shear Bond Test (SBT).....	6
4.4 Tensile Adhesion Test (TAT).....	6
5 Specimens	6
6 Torque Bond Test (TBT)	7
6.1 Apparatus.....	7
6.2 Materials.....	7
6.3 Site test method.....	7
6.4 Laboratory test method.....	8
6.5 Calculation of Torque Bond Strength and expression of results.....	9
6.6 Visual assessment of the mode of failure.....	9
6.7 Test report.....	10
6.8 Precision.....	10
7 Shear Bond Test (SBT)	11
7.1 Apparatus.....	11
7.2 Specimens.....	12
7.3 Test procedure.....	13
7.4 Calculation and Expression of Results.....	14
7.5 Test report.....	16
7.6 Precision.....	16
8 Tensile Adhesion Test (TAT)	17
8.1 Apparatus.....	17
8.2 Materials.....	18
8.3 Specimen.....	18
8.4 Test procedure.....	19
8.5 Calculation and expression of results.....	20
8.6 Test report.....	20
8.7 Precision.....	21
Annex A (informative) Compressed Shear Bond Test (CSBT)	22
Annex B (informative) Alternative Shear Bond Test (ASBT)	31
Annex C (informative) Layer Adhesion Measuring Instrument (LAMI)	34
Bibliography	45

European foreword

This document (EN 12697-48:2021) has been prepared by Technical Committee CEN/TC 227 “Road materials”, the secretariat of which is held by BSI.

This European Standard shall be given the status of a national standard, either by publication of an identical text or by endorsement, at the latest by May 2022, and conflicting national standards shall be withdrawn at the latest by May 2022.

Attention is drawn to the possibility that some of the elements of this document may be the subject of patent rights. CEN shall not be held responsible for identifying any or all such patent rights.

A list of all parts in the EN 12697 series can be found on the CEN website.

Any feedback and questions on this document should be directed to the users’ national standards body. A complete listing of these bodies can be found on the CEN website.

According to the CEN-CENELEC Internal Regulations, the national standards organisations of the following countries are bound to implement this European Standard: Austria, Belgium, Bulgaria, Croatia, Cyprus, Czech Republic, Denmark, Estonia, Finland, France, Germany, Greece, Hungary, Iceland, Ireland, Italy, Latvia, Lithuania, Luxembourg, Malta, Netherlands, Norway, Poland, Portugal, Republic of North Macedonia, Romania, Serbia, Slovakia, Slovenia, Spain, Sweden, Switzerland, Turkey and the United Kingdom.

iteh STANDARD PREVIEW
(standards.iteh.ai)

[SIST EN 12697-48:2022](https://standards.iteh.ai/catalog/standards/sist/86c575da-ed48-43df-b199-aeb70c42fc7f/sist-en-12697-48-2022)

<https://standards.iteh.ai/catalog/standards/sist/86c575da-ed48-43df-b199-aeb70c42fc7f/sist-en-12697-48-2022>

EN 12697-48:2021 (E)**1 Scope**

This document specifies test methods for determining the bond strength between an asphalt layer and other newly constructed construction layers or existing substrates in road or airfield pavements. The tests can also be applied on laboratory prepared interlayers.

The normative tests described in this document are:

- Torque Bond Test (TBT), generally applicable to any layer thicknesses;
- Shear Bond Test (SBT), generally applicable to layer thicknesses > 15 mm;
- Tensile Adhesion Test (TAT), generally applicable to layer thicknesses ≤ 15 mm.

NOTE Further non normative test methods are described in informative annexes:

- Annex A (informative) - Compressed Shear Bond Test (CSBT);
- Annex B (informative) - Alternative Shear Bond Test (ASBT);
- Annex C (informative) - Layer Adhesion Measuring Instrument (LAMI).

2 Normative references

The following documents are referred to in the text in such a way that some or all of their content constitutes requirements of this document. For dated references, only the edition cited applies. For undated references, the latest edition of the referenced document (including any amendments) applies.

EN 12697-27, *Bituminous mixtures — Test methods — Part 27: Sampling*

[SIST EN 12697-48:2022](#)

EN 12697-29, *Bituminous mixtures — Test methods — Part 29: Determination of the dimensions of a bituminous specimen*

[SIST EN 12697-48:2022](#)

EN 12697-33, *Bituminous mixtures — Test methods — Part 33: Specimen prepared by roller compactor*

3 Terms and definitions

For the purposes of this document, the following terms and definitions apply.

ISO and IEC maintain terminological databases for use in standardization at the following addresses:

- IEC Electropedia: available at <https://www.electropedia.org/>
- ISO Online browsing platform: available at <https://www.iso.org/obp>

3.1 peak shear stress of the interface

$\tau_{\text{SBT,max}}$

maximum value of shear stress [MPa] determined as the maximum force F divided by the initial cross sectional area A , of a specimen when tested as described in this document

3.2 displacement at peak shear stress

$\delta_{\text{SBT,max}}$

displacement at the maximum value of shear stress of a specimen when tested as described in this document

3.3**shear stiffness modulus** $k_{\text{SBT,max}}$

slope of the shear stress versus displacement - graph determined from the linear part of the graph

3.4**effective cross sectional area**

value of the effective contact area between the two layers of the specimen

Note 1 to entry: This area can be expressed as a function of the relative displacement of the two portions of the specimen as shown in Figure A.3.

3.5**dilatancy**ratio between the difference of the last two current recorded values of the vertical and the horizontal displacement [$d = (\eta_i - \eta_{i-1}) / (\delta_i - \delta_{i-1})$] of a specimen when tested as described in Annex A**3.6****normal stress**

ratio between the normal load and the effective cross sectional area of a specimen when tested as described in Annex A

3.7**critical condition**

shearing of the interface in residual (pure friction) condition at constant volume of a specimen when tested as described in Annex A

iTeh STANDARD PREVIEW

(standards.iteh.ai)

SIST EN 12697-48:2022

4 Principle

<https://standards.iteh.ai/catalog/standards/sist/86c575da-ed48-43df-b199-aeb70c42fc7f/sist-en-12697-48-2022>

4.1 General

The described test methods simulate different loading conditions and are applicable on different bonds between road construction layers. The methods give different results because they measure different failure modes.

4.2 Torque Bond Test (TBT)

The torque bond test assesses the resistance to horizontal shear stress:

- The torque bond test is suitable for testing the bond strength between road layers in laboratory and *in situ*;
- The torque bond test assesses the resistance to the stresses generated primarily by traffic accelerating or braking, but also by different thermal movements when the layers are of different materials;
- The torque bond test can be carried out immediately after laying;
- The torque bond test can be applied to assess the interlayer bond quality of bond coats or tack coats.

When the thickness of the top layer above the interlayer assessed is less than 15 mm, the torque bond test can be applied for evaluating the durability of the top layer.

EN 12697-48:2021 (E)

The torque bond test is carried out either *in situ* or in the laboratory using cores. A circular steel plate is glued to the top road surface *in situ* or on top of a core in a laboratory. A rotational horizontal force is applied to the steel plate and the torque moment is measured. For a top layer with a thickness < 15 mm, the steel plate is glued on top of the surface or – for the laboratory test method – a core that is larger than the plate diameter. For a top layer with a thickness \geq 15 mm, a cylindrical groove of the same dimension as the plate is cut through the upper layer down into the bottom layer.

4.3 Shear Bond Test (SBT)

The shear bond test assesses the resistance to horizontal shear stresses in the interlayer of two road construction layers.

- The shear bond test assesses the resistance to the stresses generated primarily by traffic accelerating or braking, but also by different thermal movements when the layers are of different materials;
- The shear bond test can be applied to assess the interlayer bond quality of bond coats or tack coats;
- The shear bond test is suitable to evaluate the shear bond strength of construction layers with a thickness > 15 mm.

Cylindrical test specimens are subjected to direct shear loading at controlled temperature with constant shear rate. The development of shear deformation and force is recorded and the maximum recorded shear stress is determined as shear strength (in MPa) at the interface between layers. The thickness of the layer above the interlayer of interest shall be \geq 20 mm. The core shall have a (remaining) thickness of at least 70 mm below the interface. For thinner layers than 20 mm, a grooved metal plate extension can be affixed to the specimen to minimize bulging in the top layer.

4.4 Tensile Adhesion Test (TAT)

The tensile adhesion test assesses the tensile bond strength between two road construction layers.

- The test method is generally applicable for thin surface layers (thickness \leq 15 mm);
- The tensile adhesion test can be applied to assess the interlayer bond quality of bond coats or tack coats as well as the internal cohesion of the two road construction layers.

The tensile adhesion test determines the adhesion between a surface layer and the bottom layer, perpendicular to the plane of the specimen. A test-plunger is glued on the incised and ground surface of the top layer and is pulled off with a suitable tension testing device at constant test temperature and strain rate. The maximum force related to the tension area is the adhesive tension strength in MPa.

NOTE Also the cohesion failure of the surface layer might determine the test result when the test is applied on thicker layers.

5 Specimens

The test methods to assess the interlayer bonding are either conducted on site or on specimens cored from the pavement. The interlayer bonding conditions change after laying with time, temperature and traffic loading. Therefore, the time span between laying and testing for site tests or coring of laboratory specimens shall be considered. The time span shall be reported in the test report.

The cores shall be stored fully supported. The support on which the cores rest shall be flat and clean. Cores shall not be stacked on top of each other. Cores shall be stored at a temperature between 15 °C and 25 °C for a maximum duration of 1 week. If a longer duration of storing is necessary, the storing temperature shall be between 0 °C and 5 °C.

6 Torque Bond Test (TBT)

6.1 Apparatus

6.1.1 Core cutting apparatus, suitable for cutting nominally 100 mm or 200 mm diameter cores in bituminous and hydraulically bound materials with minimum vibration, preferably using air cooling.

6.1.2 Torque meter, fitted with a reading gauge that indicates the maximum torque obtained. The device shall be calibrated over a range of 0 Nm to 400 Nm. The torque moment shall be measured to the nearest 10 Nm. The device shall be fitted with socket-fitting allowing steel plates to be fitted and removed.

6.1.3 Metal Plate of mild steel having a diameter of (95 ± 5) mm and a thickness of (14 ± 2) mm. The plate shall incorporate a fitting enabling it to be coupled to the torque meter.

NOTE Fittings of 12,7 mm and 19,05 mm have been found to be suitable.

6.1.4 Thermometer, readable to 0,1 °C and with a maximum permissible error of 0,5 °C.

6.1.5 Steel Ruler readable to 1 mm.

6.1.6 Callipers for measurement of core diameters.

6.1.7 Watch or Timer, readable and with a maximum permissible error of 1 s.

6.1.8 Mould for confining laboratory test specimens (e.g. a mould for casting concrete test cubes).

6.1.9 Spirit Level for checking laboratory test specimens.

6.1.10 Water bath of suitable size for temperature conditioning of the specimen.

6.1.11 Oven or refrigerated incubator (optional).

6.2 Materials

6.2.1 Adhesive (a stiff adhesive, such as rapid setting epoxy resin, with sufficient strength to avoid failure within the adhesive or at the adhesive/road surface interface).

6.2.2 Mounting material (*for laboratory tests*), e.g. rapid hardening mortar, concrete or grout.

6.3 Site test method

6.3.1 General

For each test location, 6 torque bond tests are conducted to evaluate one result. The test locations shall be located within 2 m of each other at least 100 mm apart. Another number of test locations may be chosen, e.g. in order to reduce the damage to the pavement. The number shall be reported.

6.3.2 For top layer thickness ≥ 15 mm, a 100 mm diameter groove shall be cored to a depth of (20 ± 5) mm below the interface to be tested. The cores shall not be removed. Where the layer thickness of the layer above the interlayer bond of interest is less than 15 mm, no coring is needed.

EN 12697-48:2021 (E)

6.3.3 Measure and record the core diameter at two locations approximately 90° apart using callipers and record the mean value, D , to the nearest 1 mm.

In the case that no groove is cored into the surface, the diameter D equals the diameter of the steel plate glued on top of the surface.

6.3.4 Ensure that all debris is removed from the rebate formed by the core barrel. Clean and dry the surface to be tested.

6.3.5 Use the adhesive to glue the metal plate to the surface of the core or the surface layer if not cored, taking care to ensure that the plate is parallel to the surface.

6.3.6 When the bonding agent has developed sufficient strength, (i.e. failure shall not occur within the adhesive), fit the torque meter to the metal plate, using adapters and extension rods as appropriate.

6.3.7 Record the pavement surface temperature in the vicinity of the test location.

6.3.8 Apply torque to the core at a steady rate so that the torque wrench sweeps an angle of 90° within (30 ± 15) s. Care shall be taken to ensure that the torque is applied parallel to the core surface (within ± 10°). Torque is applied to the plate until failure of the bond occurs or a torque of 400 Nm is exceeded. In later case, 6.3.9 to 6.3.11 are not applied.

6.3.9 Record the value of torque at failure, M , in Nm. Measure and record the bond interface temperature immediately after failure. Any interface that comes apart during preparation shall be deemed to have a bond strength of 0 Nm. Examine the core and substrate and record the condition of the bond interface (e.g. smooth, planar, rough or irregular) and record the mode of failure according to the classification in 6.6. Record the substrate type (e.g. asphalt or hydraulically bound surface).

6.3.10 Measure and record the depth of the failed interface from the pavement surface to the nearest 1 mm.

6.3.11 Calculate the bond strength in accordance with 6.5.

6.4 Laboratory test method

6.4.1 Specimens shall be cored from an in-service pavement or from a slab compacted in laboratory in accordance to EN 12697-33 with a laboratory manufactured bonding layer.

Cut six cores to a minimum depth of 80 mm below the interface being tested or down to the bottom of the asphalt layers. Extract the core taking care not to damage the surface of the core or the bond interface. For top layer thickness ≥ 15 mm, the cores shall have a diameter of (100 ± 2) mm. For top layer thickness < 15 mm, the cores shall have a diameter of (200 ± 2) mm. Another number of test specimens may be chosen, e.g. in order to reduce the damage to the pavement. The number shall be reported.

If laboratory tests are to be compared to site test results, similar duration between laying of the layer on top of the bonding layer shall be applied.

NOTE The duration between laying and compaction, coring and testing influences the test results.

6.4.2 Trim the core to a length suitable for mounting if appropriate.

6.4.3 Place the core in the mould, using mortar or grout as a bedding layer if appropriate, so that the upper layer and the bond interface to be tested is (20 ± 10) mm above the rim of the mould. Fill the mould with the mortar/grout and trim flush with the mould rim, ensuring that the core is perpendicular to and the upper surface parallel with the mould surface. Check using the spirit level.

6.4.4 Glue the metal plate to the core surface using the adhesive and allow to set.

6.4.5 Condition the mounted cores by storing at a temperature of (20 ± 2) °C for a minimum of 4 h before testing. Record the times and temperatures employed.

The standard test temperature is (20 ± 2) °C.

Other test temperatures may be applied for other purposes.

NOTE Example of other purpose can be when data obtained from site tests carried out at a temperature other than (20 ± 2) °C is subject to comparison.

6.4.6 Test the core at a temperature of (20 ± 2) °C. If other temperatures are used, the test shall be completed within five minutes of removal from the conditioning environment.

6.4.7 Fix or clamp the mould containing the mounted core to a suitably rigid surface. Carry out the test as described in 6.3.8.

6.4.8 Examine the core and record all the relevant information as described in 6.6 and 6.7.

6.5 Calculation of Torque Bond Strength and expression of results

6.5.1 Calculate the torque bond strength $\tau_{\text{TBT,max}}$ for each specimen using the following formula:

$$\tau_{\text{TBT,max}} = \frac{16 \times M \times 10^6}{\pi \times D^3} \quad (1)$$

where

$\tau_{\text{TBT,max}}$ inter-layer torque shear bond strength, in kilopascals (kPa),

M peak value of applied shearing torque, in newton metres (Nm),

D diameter of core, in millimetres (mm).

6.5.2 Calculate the arithmetic mean of the torque bond strength measured on the six specimens / locations.

6.6 Visual assessment of the mode of failure

In case of failure of the interface, the visual assessment of the failed surface shall be determined according to the following classification:

- within the surface layer (cohesion failure),
- partly at the interface, partly in the surfacing layer (mixed failure),
- at the interface (adhesion failure),
- partly in the bottom layer, partly at the interface (mixed failure),

EN 12697-48:2021 (E)

- e) in the bottom layer (cohesion failure),
- f) partly or completely in the adhesive.

If a mixed failure is observed, the proportions of the failure modes shall be estimated with a maximum permissible error of 10 %.

In the case, that the interface did not fail, “no failure” shall be recorded.

6.7 Test report

The test report shall include the following information:

- a) name of organization carrying out the test;
- b) reference to this document;
- c) method of test used (*in situ*, laboratory) and if cored or not;
- d) description of materials (system and substrate);
- e) date of test;
- f) number of tests conducted per location or number of tested laboratory specimens;
- g) peak torque at failure (Nm) for individual cores;
- h) inter-layer torque bond strength τ_{TBT} (kPa), (individual and mean values);
- i) time to failure (seconds);
- j) diameter of cores (mm) if appropriate;
- k) depths of Bond interface (mm);
- l) temperature of the pavement surface or the specimen (°C);
- m) conditioning details (duration and temperature);
- n) site or laboratory test;
- o) identification of site or scheme;
- p) specimen or location number;
- q) age of the tested interface at the time of test;
- r) mode of failure.

6.8 Precision

The precision for this test method has not been determined.

7 Shear Bond Test (SBT)

7.1 Apparatus

7.1.1 Shear test apparatus, as shown in Figure 1, composed of a base body (A) on which are fixed the sample support (B) and the lower shear ring (C). The upper shear ring (D) is attached to the upper body (E), which is movable vertically along the guiding bars (F).

A gap width ≤ 5 mm is recommended.

NOTE The gap width between shear rings influences the test results.

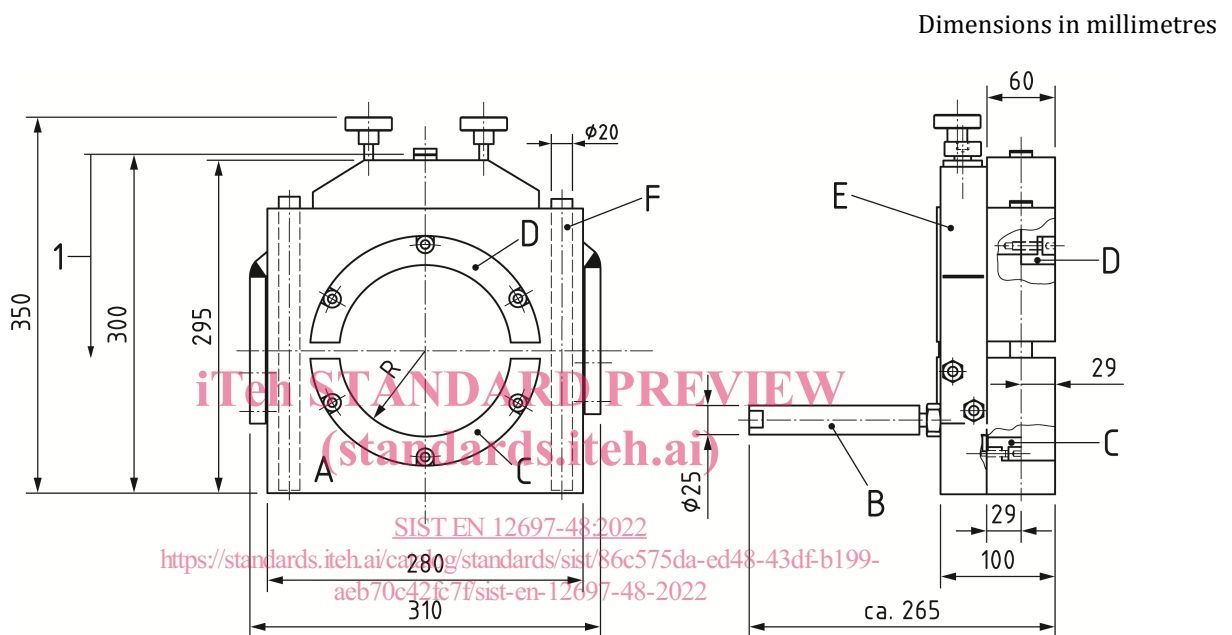

Key

- A base body
- B sample support
- C lower shear ring
- D upper shear ring
- E upper body
- F guiding bar
- 1 range max. ± 20 mm

Figure 1—Schematic diagram of the Shear Bond Test apparatus

7.1.2 Loading frame capable of achieving a constant vertical displacement rate of $(50,0 \pm 2)$ mm per minute up to a displacement of at least 7 mm and a maximum load of at least 35 kN.

7.1.3 Data logging system to record load and displacement during the test.

7.1.4 Metal plate extension as shown in Figure 2, composed of aluminium or other metal.

7.1.5 Adhesive (a stiff adhesive, such as rapid setting epoxy resin, with sufficient strength to avoid failure within the adhesive or at the adhesive/thin surfacing interface).