



# SLOVENSKI STANDARD

## SIST EN 13888-2:2022

01-november-2022

### Nadomešča:

SIST EN 12808-1:2009

SIST EN 12808-2:2009

SIST EN 12808-3:2009

SIST EN 12808-4:2009

SIST EN 12808-4:2009/AC:2011

SIST EN 12808-5:2009

---

**Fugirne mase za keramične ploščice - 2. del: Preskusne metode**

Grouts for ceramic tiles - Part 2: Test methods

[SIST EN 13888-2:2022](https://standards.iteh.ai/catalog/standards/sist/30f54e2a-0227-4930-b067-57233010d731/EN-13888-2-2022)

Fugenmörtel für keramische Fliesen und Platten - Teil 2: Prüfverfahren

Mortiers de jointoiement pour carreaux et dalles céramiques - Partie 2 : Méthodes d'essai

**Ta slovenski standard je istoveten z: EN 13888-2:2022**

---

### **ICS:**

91.100.10 Cement. Mavec. Apno. Malta Cement. Gypsum. Lime.  
Mortar

91.100.23 Keramične ploščice Ceramic tiles

**SIST EN 13888-2:2022**

**en,fr,de**



EUROPEAN STANDARD

EN 13888-2

NORME EUROPÉENNE

EUROPÄISCHE NORM

September 2022

ICS 91.100.10

Supersedes EN 12808-1:2008, EN 12808-2:2008, EN 12808-3:2008, EN 12808-4:2009, EN 12808-5:2008

English Version

## Grouts for ceramic tiles - Part 2: Test methods

Mortiers de jointoiment pour carreaux et dalles  
céramiques - Partie 2 : Méthodes d'essaiFugenmörtel für keramische Fliesen und Platten - Teil  
2: Prüfverfahren

This European Standard was approved by CEN on 8 August 2022.

CEN members are bound to comply with the CEN/CENELEC Internal Regulations which stipulate the conditions for giving this European Standard the status of a national standard without any alteration. Up-to-date lists and bibliographical references concerning such national standards may be obtained on application to the CEN-CENELEC Management Centre or to any CEN member.

This European Standard exists in three official versions (English, French, German). A version in any other language made by translation under the responsibility of a CEN member into its own language and notified to the CEN-CENELEC Management Centre has the same status as the official versions.

CEN members are the national standards bodies of Austria, Belgium, Bulgaria, Croatia, Cyprus, Czech Republic, Denmark, Estonia, Finland, France, Germany, Greece, Hungary, Iceland, Ireland, Italy, Latvia, Lithuania, Luxembourg, Malta, Netherlands, Norway, Poland, Portugal, Republic of North Macedonia, Romania, Serbia, Slovakia, Slovenia, Spain, Sweden, Switzerland, Türkiye and United Kingdom.

[SIST EN 13888-2:2022](https://standards.iteh.ai/catalog/standards/sist/30f54e2a-0227-4930-b067-5123d8c16fd1/sist-en-13888-2-2022)

<https://standards.iteh.ai/catalog/standards/sist/30f54e2a-0227-4930-b067-5123d8c16fd1/sist-en-13888-2-2022>



EUROPEAN COMMITTEE FOR STANDARDIZATION  
COMITÉ EUROPÉEN DE NORMALISATION  
EUROPÄISCHES KOMITEE FÜR NORMUNG

CEN-CENELEC Management Centre: Rue de la Science 23, B-1040 Brussels

<b>Contents</b>	<b>Page</b>
<b>European foreword</b> .....	<b>3</b>
<b>1 Scope</b> .....	<b>4</b>
<b>2 Normative references</b> .....	<b>4</b>
<b>3 Terms and definitions</b> .....	<b>4</b>
<b>4 Sampling</b> .....	<b>4</b>
<b>5 Test conditions</b> .....	<b>5</b>
<b>6 Test materials</b> .....	<b>5</b>
<b>7 Mixing of grouts</b> .....	<b>5</b>
<b>8 Test report</b> .....	<b>6</b>
<b>9 Test methods</b> .....	<b>6</b>
<b>9.1 Determination of flexural and compressive strength</b> .....	<b>6</b>
<b>9.2 Determination of water absorption</b> .....	<b>10</b>
<b>9.3 Determination of shrinkage</b> .....	<b>12</b>
<b>9.4 Determination of resistance to abrasion</b> .....	<b>16</b>
<b>9.5 Determination of chemical resistance</b> .....	<b>20</b>
<b>Bibliography</b> .....	<b>24</b>

[SIST EN 13888-2:2022](https://standards.iteh.ai/catalog/standards/sist/30f54e2a-0227-4930-b067-5123d8c16fd1/sist-en-13888-2-2022)

<https://standards.iteh.ai/catalog/standards/sist/30f54e2a-0227-4930-b067-5123d8c16fd1/sist-en-13888-2-2022>

## European foreword

This document (EN 13888-2:2022) has been prepared by Technical Committee CEN/TC 67 “Ceramic tiles”, the secretariat of which is held by UNI.

This European Standard shall be given the status of a national standard, either by publication of an identical text or by endorsement, at the latest by March 2023, and conflicting national standards shall be withdrawn at the latest by March 2023.

Attention is drawn to the possibility that some of the elements of this document may be the subject of patent rights. CEN shall not be held responsible for identifying any or all such patent rights.

This document supersedes EN 12808-1:2008, EN 12808-2:2008, EN 12808-3:2008, EN 12808-4:2009 and EN 12808-5:2008.

This document belongs to series EN 13888, *Grouts for ceramic tiles*, which consists of the following parts:

- *Part 1: Requirements, classification, designation, marking and labelling;*
- *Part 2: Test methods.*

Any feedback and questions on this document should be directed to the users’ national standards body. A complete listing of these bodies can be found on the CEN website.

According to the CEN-CENELEC Internal Regulations, the national standards organisations of the following countries are bound to implement this European Standard: Austria, Belgium, Bulgaria, Croatia, Cyprus, Czech Republic, Denmark, Estonia, Finland, France, Germany, Greece, Hungary, Iceland, Ireland, Italy, Latvia, Lithuania, Luxembourg, Malta, Netherlands, Norway, Poland, Portugal, Republic of North Macedonia, Romania, Serbia, Slovakia, Slovenia, Spain, Sweden, Switzerland, Türkiye and the United Kingdom.

## EN 13888-2:2022 (E)

### 1 Scope

This document specifies the methods for determining characteristics for grouts used in internal and external installation of ceramic tiles.

This document does not contain performance requirements or recommendations for the design and installation of ceramic tiles.

The following test methods are described:

- Determination of flexural and compressive strength (9.1);
- Determination of water absorption (9.2);
- Determination of shrinkage (9.3);
- Determination of resistance to abrasion (9.4);
- Determination of chemical resistance (9.5).

Grouts for ceramic tiles can also be used for other kinds of tiles (natural and agglomerated stones, etc.), if they do not adversely affect the stones.

**WARNING** — This document can involve hazardous materials and operations. It is important that persons using this document are familiar with normal laboratory practice. This document does not purport to address all the safety problems, if any, associated with its use. It is the responsibility of the user to establish appropriate safety and health practices and to ensure compliance with any European and national regulatory conditions.

### 2 Normative references

The following documents are referred to in the text in such a way that some or all of their content constitutes requirements of this document. For dated references, only the edition cited applies. For undated references, the latest edition of the referenced document (including any amendments) applies.

EN 196-1:2016, *Methods of testing cement - Part 1: Determination of strength*

EN 1067, *Adhesives - Examination and preparation of samples for testing*

EN ISO 10545-6, *Ceramic tiles - Part 6: Determination of resistance to deep abrasion for unglazed tiles (ISO 10545-6)*

EN ISO 15605, *Adhesives - Sampling (ISO 15605)*

### 3 Terms and definitions

No terms and definitions are listed in this document.

ISO and IEC maintain terminological databases for use in standardization at the following addresses:

- ISO Online browsing platform: available at <https://www.iso.org/obp>
- IEC Electropedia: available at <https://www.electropedia.org/>

### 4 Sampling

Take at least 2 kg sample of the grout in accordance with EN ISO 15605 and EN 1067.

## 5 Test conditions

Standard conditions shall be  $(23 \pm 2)$  °C and  $(50 \pm 5)$  % relative humidity and the speed of air in the testing area less than 0,2 m/s.

The tolerance in the time of conditioning for all test specimens shall be as shown in Table 1 below:

**Table 1 — Allowed tolerance in testing time for all specimens requiring conditioning**

Specimen conditioning time	Allowed tolerance for testing
6 h	±15 min
7 d	±3 h
14 d	±6 h
21 d	±9 h
28 d	±12 h

Testing shall be performed within the specified time window.

## 6 Test materials

Condition all test materials for at least 24 h under standard conditions.

The grout to be tested shall be within its shelf life, where this is specified.

## 7 Mixing of grouts

The amount of water and/or liquid admix required for preparing the cementitious grout shall be as stated by the manufacturer in parts by weight, i.e. liquid to dry powder.

Prepare at least 2 kg of the grout in a mixer of the type described in EN 196-1:2016, 4.4, using the slow speed settings,  $(140 \pm 5)$  r/min rotation and  $(62 \pm 5)$  r/min planetary movement.

Carry out the following procedure:

- pour the liquid into the pan;
- scatter the dry powder over the liquid;
- mix for 30 s;
- take out the mixing paddle;
- scrape down the paddle and pan within 1 min;
- put the paddle back in place and mix for 1 min.

Let the grout mature if and as specified in the manufacturer's instructions, and then mix for a further 15 s.

In the case of reaction resin grouts, follow the manufacturer's instructions.

**EN 13888-2:2022 (E)****8 Test report**

The test report shall provide the following information:

- a) number, title and issue of this document;
- b) place and date of sampling;
- c) type of grout, commercial designation and manufacturer name;
- d) identification of the test sample;
- e) handling and storage of samples before testing;
- f) test conditions;
- g) date of testing;
- h) amount of water or liquid used for preparing the grout;
- i) result of the visual inspection of the specimen before testing;
- j) any other factor that could have influenced the result;
- k) test results (individual and mean values and mode of failure where required):
  - 1) flexural and compressive strength;
  - 2) water absorption;
  - 3) shrinkage
  - 4) resistance to abrasion;
  - 5) chemical resistance.

**9 Test methods****9.1 Determination of flexural and compressive strength****9.1.1 Apparatus**

**9.1.1.1** Three gang mould shall consist of three horizontal compartments so that three prismatic specimens 40 mm x 40 mm x 160 mm can be prepared simultaneously (see EN 196-1:2016, 4.5).

**9.1.1.2** Jolting apparatus or jolting table used for the compaction of 40 mm x 40 mm x 160 mm grout specimen, which shall comply with EN 196-1:2016, 4.6.

**9.1.1.3** Flexural strength testing machine shall be capable of applying the load with suitable capacity and sensitivity for the test. The machine shall be provided with a flexure device in accordance with EN 196-1:2016, 4.7 (see Figure 1).



**9.1.1.4** Compressive strength testing machine shall comply with EN 196-1:2016, 4.8. The test requires the use of a jig (in accordance with EN 196-1:2016, 4.9) to be incorporated in the lower platen; the upper platen receives the load from the machine through an intermediate spherical seating (see Figure 2).

### **9.1.2 Preparation of test specimens**

Mould the specimens immediately after the preparation of the grout, with the mould firmly clamped to the jolting table.

Introduce, using a suitable scoop, the first of two layers of grout into each of the compartments, directly from the mixing bowl. Spread the layer uniformly, then compact using 60 jolts.

Introduce the second layer of grout, level and compact with a further 60 jolts.

Lift the mould gently from the jolting table, strike off excess of material and smooth the surface with a flat trowel. Wipe off the grout left on the perimeter of the mould.

Cover the mould with a glass plate according to EN 196-1.

Place the mould, suitably identified, on a horizontal base in standard conditions,  $(23 \pm 2)$  °C and  $(50 \pm 5)$  % R.H.

After 24 h carefully remove the specimen from the mould.

Keep the demoulded prism in standard conditions for 27 d, leaving a clearance of at least 25 mm on all sides.

Prepare three specimens for each grout.

### **9.1.3 Flexural strength under standard conditions**

After conditioning has been completed, place the prism in the testing machine (9.1.1.3) with one side face on the supporting rollers and with the longitudinal axis normal to the support.

Apply the load vertically in accordance with the procedure described in EN 196-1:2016, 9.1.

Keep the prism halves in standard conditions until tested in compression.

### **9.1.4 Compressive strength under standard conditions**

Test the prism halves broken in flexion, by means of the equipment specified in 9.1.1.4 and following the procedure described in EN 196-1:2016, 9.2.

### **9.1.5 Flexural and compressive strength after freeze-thaw cycles**

Prepare the test units in accordance with 9.1.2.

Condition the test units for 6 d in standard conditions and then immerse in water for 21 d before carrying out 25 freeze-thaw cycles, in accordance with the following procedure.

For each freeze-thaw cycle:

- remove the test units from the water and lower the temperature to  $(-15 \pm 3)$  °C within  $2 \text{ h} \pm 20 \text{ min}$ ;
- maintain the test units at  $(-15 \pm 3)$  °C for  $2 \text{ h} \pm 20 \text{ min}$ ;
- immerse the test units in water at  $(20 \pm 3)$  °C and raise the temperature of water to  $(15 \pm 3)$  °C for at least  $2 \text{ h} \pm 20 \text{ min}$ .

Repeat the cycle 25 times.

**EN 13888-2:2022 (E)**

Condition the test units for 3 d in standard conditions after the last cycle and prior to test examine them and record a brief description of surface appearance of the specimen. Determine the flexural strength in accordance with 9.1.3 and the compressive strength in accordance with 9.1.4.

**9.1.6 Evaluation of results****9.1.6.1 Flexural strength**

The flexural strength ( $R_f$ ) is calculated from:

$$R_f = \frac{1,5 F_f L}{b^3} N / mm^2 \quad (1)$$

where

$b$  is the length of the side of the square section of the prism, in millimetres;

$F_f$  is the load applied to the middle of the prism at fracture, in newtons;

$L$  is the distance between the supports, in millimetres.

Calculate the mean of the three determinations to the nearest 0,1 N / mm<sup>2</sup>.

**9.1.6.2 Compressive strength**

The compressive strength ( $R_c$ ) is calculated from:

$$R_c = \frac{F_c}{1\,600} N / mm^2 \quad (2)$$

where

$F_c$  is the maximum load at fracture, in newtons;

1 600 = 40 mm x 40 mm is the area of the platens or auxiliary plates, in square millimetres.

Calculate the mean of the six results obtained from the test to the nearest 0,1 N / mm<sup>2</sup>.

**9.1.7 Test report**

The information listed in Clause 8, items a) to j) shall be provided plus item k) 1: flexural and compressive strength.

Dimensions in millimetres

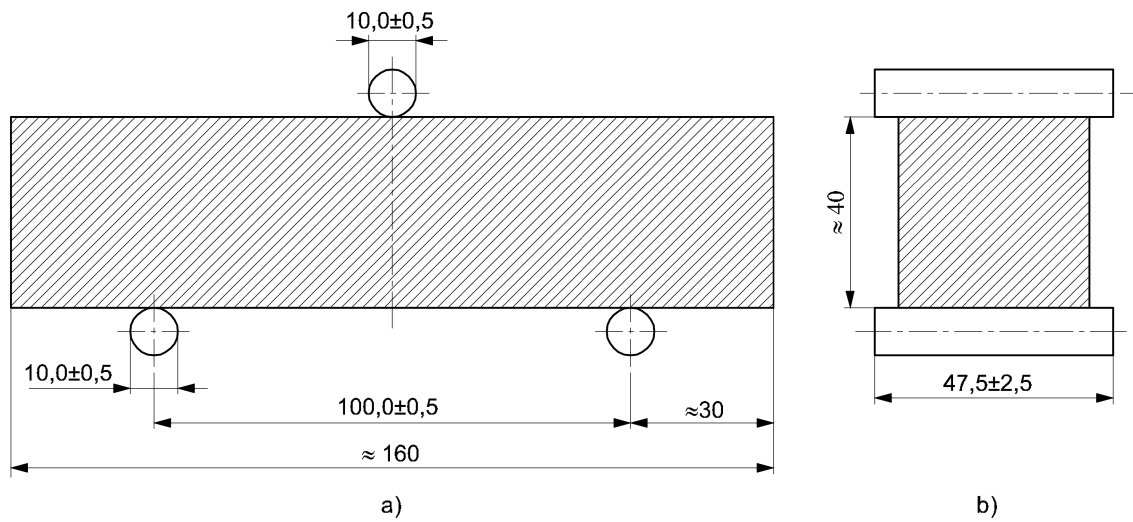

Figure 1 — Arrangement of loading for determination of flexural strength

iTeh STANDARD PREVIEW  
(standards.iteh.ai)

[SIST EN 13888-2:2022](https://standards.iteh.ai/catalog/standards/sist/30f54e2a-0227-4930-b067-5123d8c16fd1/sist-en-13888-2-2022)

<https://standards.iteh.ai/catalog/standards/sist/30f54e2a-0227-4930-b067-5123d8c16fd1/sist-en-13888-2-2022>